



FEVEREIRO 2022

# PROJETO EXECUTIVO DE INFRAESTRUTURA

VOLUME 03 - RELATÓRIO DE  
TERRAPLENAGEM

LOCAL: LEOBERTO LEAL/SC  
RUA: MAINOLVO LEHMKUHL  
EXTENSÃO: 2404,74 METROS





## RELATÓRIO DE ALINHAMENTO HORIZONTAL POR ESTACA

Estaca	Norte	Este
0+0,000	6957726,0072152	669467,0839617
1+0,000	6957745,2345130	669472,5895058
1+16,843 PC	6957761,4270381	669477,2260731
2+0,000	6957764,5144285	669477,8759622
3+0,000	6957783,6683455	669473,8409562
3+1,550 PCC	6957784,9529559	669472,9735167
4+0,000	6957798,6201090	669460,6201658
4+11,318 PCR	6957805,7725202	669451,8570752
5+0,000	6957812,1956989	669446,0731938
5+9,032 PCC	6957820,4791878	669442,5828120
6+0,000	6957831,3259860	669441,0547286
6+12,835 PCC	6957844,1252347	669441,6600998
7+0,000	6957851,1250744	669443,1751766
8+0,000	6957869,5363244	669450,8342820
8+0,452 PT	6957869,9259598	669451,0628621
8+4,421 PC	6957873,3653241	669453,0438305
9+0,000	6957886,7344705	669461,0413002
10+0,000	6957904,2357320	669470,7189656
10+14,159 PCR	6957916,8431574	669477,1627959
11+0,000	6957921,9173821	669480,0539650
12+0,000	6957937,9426347	669491,9708982
12+9,774 PCR	6957944,8923831	669498,8381109
13+0,000	6957952,1996338	669505,9818275
14+0,000	6957968,8746175	669516,9257202
14+17,673 PT	6957985,5009981	669522,8050421
15+0,000	6957987,7492226	669523,4058899
16+0,000	6958007,0710914	669528,5697438
16+14,726 PC	6958021,2974323	669532,3717956
17+0,000	6958026,3144641	669533,9965782
18+0,000	6958044,2207931	669542,8075483
19+0,000	6958059,6718460	669555,4382557
19+9,594 PT	6958065,9717735	669562,6678812
20+0,000	6958072,5215336	669570,7537766
21+0,000	6958085,1101830	669586,2948803
22+0,000	6958097,6988324	669601,8359841



23+0,000	6958110,2874817	669617,3770879
24+0,000	6958122,8761311	669632,9181917
25+0,000	6958135,4647805	669648,4592955
26+0,000	6958148,0534298	669664,0003993
27+0,000	6958160,6420792	669679,5415031
28+0,000	6958173,2307286	669695,0826069
29+0,000	6958185,8193780	669710,6237107
30+0,000	6958198,4080273	669726,1648145
31+0,000	6958210,9966767	669741,7059183
31+17,516 PC	6958222,0220725	669755,3171339
32+0,000	6958223,6300251	669757,2099191
33+0,000	6958237,4262942	669771,6776444
34+0,000	6958252,6263060	669784,6627034
34+2,577 PT	6958254,6791297	669786,2210070
34+17,183 PC	6958266,3868945	669794,9528832
35+0,000	6958268,5928516	669796,7050342
36+0,000	6958285,9100240	669806,5913292
36+14,936 PCC	6958300,2186288	669810,7872653
37+0,000	6958305,2086211	669811,6498830
38+0,000	6958325,0410850	669814,2023542
39+0,000	6958345,0022322	669815,3831744
40+0,000	6958364,9973103	669815,1867385
41+0,000	6958384,9314057	669813,6139789
41+1,240 PCR	6958386,1628497	669813,4713284
42+0,000	6958404,7185750	669810,7106953
43+0,000	6958424,5609410	669808,2081031
43+4,371 PCC	6958428,9048846	669807,7218094
44+0,000	6958444,4957868	669807,6418502
45+0,000	6958463,6968665	669812,9481632
46+0,000	6958480,3807261	669823,8333480
46+11,061 PT	6958487,9370478	669831,8929838
47+0,000	6958493,3618113	669838,9973795
48+0,000	6958505,4995021	669854,8931796
48+7,503 PC	6958510,0530198	669860,8565716
49+0,000	6958517,0873485	669871,1854667
50+0,000	6958527,9392624	669887,9844565
50+3,122 PCR	6958529,5878911	669890,6362019
51+0,000	6958541,0827787	669902,8794254



51+0,857 PCR	6958541,7722934	669903,3878748
52+0,000	6958557,0137553	669914,9647192
53+0,000	6958572,0633840	669928,1306711
53+11,227 PCC	6958580,0923449	669935,9770429
54+0,000	6958586,0531671	669942,4137680
55+0,000	6958599,1995464	669957,4841310
56+0,000	6958611,7123907	669973,0845110
56+17,997 PCR	6958622,4126568	669987,5532892
57+0,000	6958623,5260780	669989,2187477
58+0,000	6958635,7420822	670005,0382319
58+9,608 PCC	6958642,2860266	670012,0707125
59+0,000	6958651,1471062	670017,3174380
59+3,798 PT	6958654,8532697	670018,1277457
60+0,000	6958670,9250060	670020,1754855
61+0,000	6958690,7646167	670022,7032995
62+0,000	6958710,6042275	670025,2311136
62+2,403 PC	6958712,9876171	670025,5347871
63+0,000	6958730,5372770	670026,6385063
63+4,260 PCC	6958734,7963683	670026,5536284
63+18,903 PT	6958749,2788446	670024,6161352
64+0,000	6958750,3391330	670024,3338842
65+0,000	6958769,6660653	670019,1890141
65+4,282 PC	6958773,8037005	670018,0875669
66+0,000	6958788,4929422	670012,5696627
66+2,269 PCC	6958790,5102839	670011,5317265
67+0,000	6958805,5803503	670002,1913993
67+6,370 PT	6958810,8948815	669998,6802395
68+0,000	6958822,3828645	669991,3446485
68+18,060 PC	6958837,6045146	669981,6249440
69+0,000	6958839,3194782	669980,7192868
70+0,000	6958858,8117337	669978,7621761
70+4,165 PCC	6958862,7555507	669980,0904284
71+0,000	6958876,9436560	669987,0872534
72+0,000	6958893,0768826	669998,8554703
72+4,975 PCC	6958896,7162978	670002,2468252
73+0,000	6958907,3481338	670012,8576632
74+0,000	6958920,1076150	670028,2463158
75+0,000	6958931,1424678	670044,9150595



75+19,914 PCR	6958940,2898581	670062,5928857
76+0,000	6958940,3267424	670062,6708161
77+0,000	6958950,2560806	670080,0087453
78+0,000	6958962,7494492	670095,6007716
79+0,000	6958977,5057013	670109,0710562
79+10,007 PCC	6958985,6289934	670114,9107166
80+0,000	6958994,9714648	670118,2879648
80+10,633 PCR	6959005,5244135	670117,8505282
81+0,000	6959014,7126594	670116,0709827
82+0,000	6959034,6213637	670116,7682078
82+14,685 PT	6959048,6101667	670121,1307279
83+0,000	6959053,4454312	670123,3384010
83+8,234 PC	6959060,9359107	670126,7583857
84+0,000	6959071,8545560	670131,1300075
84+6,994 PT	6959078,5247126	670133,2309405
84+17,690 PC	6959088,8126303	670136,1549595
85+0,000	6959091,0325756	670136,7954239
86+0,000	6959110,1861927	670142,5509355
86+13,689 PCC	6959123,2281138	670146,7079893
87+0,000	6959129,2168441	670148,6997419
88+0,000	6959147,7738617	670156,1400105
89+0,000	6959165,5726651	670165,2462226
89+4,002 PCC	6959169,0297227	670167,2618155
90+0,000	6959182,5004163	670175,8869310
90+17,875 PCC	6959196,8505118	670186,5379867
91+0,000	6959198,4831394	670187,8981993
92+0,000	6959211,1598897	670203,2459421
92+1,564 PCC	6959211,9224478	670204,6114793
93+0,000	6959219,5802808	670221,3757597
93+13,718 PCR	6959224,3505560	670234,2349048
94+0,000	6959226,4626726	670240,1514810
95+0,000	6959233,7923730	670258,7577841
95+6,356 PCC	6959236,3127429	670264,5926081
96+0,000	6959243,0631994	670276,4434501
97+0,000	6959254,9725077	670292,4897084
97+10,959 PCC	6959262,4371107	670300,5096443
98+0,000	6959268,9698930	670306,7584876
99+0,000	6959284,3455281	670319,5366701



100+0,000	6959300,8765786	670330,7801781
101+0,000	6959318,4104194	670340,3852044
101+2,545 PCR	6959320,7057358	670341,4854133
102+0,000	6959336,1646832	670349,5617316
103+0,000	6959352,3622651	670361,2600247
104+0,000	6959366,5759633	670375,3021935
104+6,229 PCR	6959370,5433875	670380,1034471
105+0,000	6959379,2292879	670390,7897345
106+0,000	6959391,8533997	670406,3020452
106+19,128 PT	6959403,9374211	670421,1294759
107+0,000	6959404,5144063	670421,7834322
108+0,000	6959417,7463866	670436,7805884
109+0,000	6959430,9783670	670451,7777447
110+0,000	6959444,2103473	670466,7749010
111+0,000	6959457,4423276	670481,7720573
112+0,000	6959470,6743080	670496,7692136
113+0,000	6959483,9062883	670511,7663698
113+3,448 PC	6959486,1874115	670514,3518000
114+0,000	6959497,0610906	670526,8301059
114+19,317 PCR	6959509,1972139	670541,8564845
115+0,000	6959509,6370703	670542,3796187
116+0,000	6959522,6256200	670557,5878460
117+0,000	6959535,8393279	670572,6008578
118+0,000	6959549,2752604	670587,4153209
119+0,000	6959562,9304345	670602,0279462
120+0,000	6959576,8018185	670616,4354896
120+4,743 PT	6959580,1225000	670619,8215000



## RELATÓRIO DE ALINHAMENTO VERTICAL POR ESTACA

Estaca	Cota
0+0,000	546,00000
1+0,000	545,0651885
1+16,843 PC	544,2329729
2+0,000	544,0690104
3+0,000	542,9715855
3+1,550 PCC	542,8822929
4+0,000	541,7729137
4+11,318 PCR	541,0497464
5+0,000	540,4729952
5+9,032 PCC	539,8527316
6+0,000	539,0718299
6+12,835 PCC	538,1192691
7+0,000	537,5694177
8+0,000	535,9657588
8+0,452 PT	535,9283681
8+4,421 PC	535,5976229
9+0,000	534,2608531
10+0,000	532,4547006
10+14,159 PCR	531,1148068
11+0,000	530,5479412
12+0,000	528,6013017
12+9,774 PCR	527,6500100
13+0,000	526,6546623
14+0,000	524,7080228
14+17,673 PT	522,9878874
15+0,000	522,7613833
16+0,000	521,0022376
16+14,726 PC	519,9882352
17+0,000	519,6832642
18+0,000	518,8058210
19+0,000	518,3685502
19+9,594 PT	518,2487299
20+0,000	518,1187731
21+0,000	517,8689961
22+0,000	517,6192190



23+0,000	517,3694419
24+0,000	517,1196648
25+0,000	516,8698878
26+0,000	516,6201107
27+0,000	516,3703336
28+0,000	516,1205566
29+0,000	515,8707795
30+0,000	515,6313754
31+0,000	515,4182401
31+17,516 PC	515,2532917
32+0,000	515,2315460
33+0,000	515,0712931
34+0,000	514,9374815
34+2,577 PT	514,9221610
34+17,183 PC	514,8436358
35+0,000	514,8301111
36+0,000	514,7491819
36+14,936 PCC	514,7059905
37+0,000	514,6946939
38+0,000	514,6666471
39+0,000	514,6650416
40+0,000	514,6795043
41+0,000	514,6941394
41+1,240 PCR	514,6950466
42+0,000	514,7087746
43+0,000	514,7234098
43+4,371 PCC	514,7266083
44+0,000	514,7380449
45+0,000	514,8702511
46+0,000	515,3361364
46+11,061 PT	515,7391181
47+0,000	516,1403834
48+0,000	517,2829922
48+7,503 PC	517,7989277
49+0,000	518,7639628
50+0,000	520,5786124
50+3,122 PCR	520,8802764
51+0,000	522,5108331





51+0,857 PCR	522,5936018
52+0,000	524,4430538
53+0,000	526,3754053
53+11,227 PCC	527,4605382
54+0,000	528,3087204
55+0,000	530,2431463
56+0,000	532,1786829
56+17,997 PCR	533,9212887
57+0,000	534,1153303
58+0,000	536,0530884
58+9,608 PCC	536,9843454
59+0,000	537,9919573
59+3,798 PT	538,3603065
60+0,000	539,9319369
61+0,000	541,8730273
62+0,000	543,8152284
62+2,403 PC	544,0486254
63+0,000	545,7584095
63+4,260 PCC	546,1723503
63+18,903 PT	547,5951255
64+0,000	547,7017377
65+0,000	549,6450660
65+4,282 PC	550,0611063
66+0,000	551,5883942
66+2,269 PCC	551,8088430
67+0,000	553,5309457
67+6,370 PT	554,0785020
68+0,000	554,8608446
68+18,060 PC	555,0800114
69+0,000	555,0481412
70+0,000	554,0928357
70+4,165 PCC	553,7501254
71+0,000	552,2523814
72+0,000	550,3542599
72+4,975 PCC	549,8833698
73+0,000	548,4643439
74+0,000	546,5826336
75+0,000	544,7091291



75+19,914 PCR	542,8518539
76+0,000	542,8438304
77+0,000	540,9867373
78+0,000	539,1378501
79+0,000	537,2971685
79+10,007 PCC	536,3792639
80+0,000	535,4646927
80+10,633 PCR	534,4938089
81+0,000	533,6404226
82+0,000	531,8203003
82+14,685 PT	530,4839130
83+0,000	530,0001781
83+8,234 PC	529,2508071
84+0,000	528,1800559
84+6,994 PT	527,5435470
84+17,690 PC	526,5702022
85+0,000	526,3599337
86+0,000	524,5398115
86+13,689 PCC	523,2940722
87+0,000	522,7196893
88+0,000	520,8995671
89+0,000	519,0794449
89+4,002 PCC	518,7152577
90+0,000	517,2593227
90+17,875 PCC	515,6325993
91+0,000	515,4392005
92+0,000	513,6190783
92+1,564 PCC	513,4767380
93+0,000	511,7989561
93+13,718 PCR	510,5835252
94+0,000	510,0585966
95+0,000	508,5229882
95+6,356 PCC	508,0781626
96+0,000	507,1936288
97+0,000	506,0705187
97+10,959 PCC	505,5425768
98+0,000	505,1536577
99+0,000	504,4430459



100+0,000	503,9376720
101+0,000	503,5160103
101+2,545 PCR	503,4623456
102+0,000	503,0943487
103+0,000	502,6852561
104+0,000	502,3087433
104+6,229 PCR	502,1981851
105+0,000	501,9650668
106+0,000	501,6542268
106+19,128 PT	501,3876609
107+0,000	501,3762232
108+0,000	501,1310560
109+0,000	500,9187252
110+0,000	500,7392308
111+0,000	500,5922896
112+0,000	500,4577376
113+0,000	500,3249351
113+3,448 PC	500,3056992
114+0,000	500,2450476
114+19,317 PCR	500,2405977
115+0,000	500,2417489
116+0,000	500,3150390
117+0,000	500,4649178
118+0,000	500,6913855
119+0,000	500,9912140
120+0,000	501,3103287
2+404,74 PT	501,3860000



## RELATÓRIO DE CORTE E ATERRO

Estacas	Área de Corte (m <sup>2</sup> )	Volume de Corte (m <sup>3</sup> )	Área de Aterro (m <sup>2</sup> )	Volume de Aterro (m <sup>3</sup> )	Volum. Corte Acum. (m <sup>3</sup> )	Volum. Aterro Acum. (m <sup>3</sup> )	Volume Líquido (m <sup>3</sup> )
0+000.00	3.33	0.00	0.00	0.00	0.00	0.00	0.00
0+020.00	0.88	42.15	0.05	0.49	42.15	0.49	41.67
0+036.84	1.49	19.96	0.33	3.22	62.12	3.71	58.41
0+040.00	2.60	6.80	0.58	1.22	68.92	4.92	64.00
0+049.20	4.29	33.25	0.25	3.26	102.17	8.19	93.98
0+060.00	5.93	59.17	0.03	1.27	161.34	9.46	151.88
0+061.55	5.90	9.96	0.02	0.03	171.30	9.49	161.81
0+076.43	4.62	80.33	0.11	0.96	251.63	10.46	241.17
0+080.00	4.49	16.57	0.43	0.94	268.20	11.39	256.81
0+091.32	3.11	43.38	0.00	2.36	311.58	13.75	297.83
0+100.00	4.91	33.82	0.00	0.00	345.40	13.76	331.65
0+100.18	4.99	0.87	0.00	0.00	346.27	13.76	332.51
0+109.03	3.84	37.42	0.01	0.05	383.69	13.80	369.89
0+120.00	3.74	40.70	0.01	0.09	424.39	13.89	410.50
0+120.93	3.84	3.54	0.01	0.01	427.93	13.90	414.03
0+132.84	3.09	40.03	0.01	0.14	467.95	14.04	453.92
0+140.00	2.42	19.45	0.01	0.09	487.41	14.12	473.29
0+146.64	2.31	15.73	0.02	0.10	503.14	14.22	488.92
0+160.00	2.79	33.53	0.03	0.30	536.67	14.52	522.15
0+160.45	2.75	1.25	0.03	0.01	537.92	14.53	523.40
0+164.42	1.91	9.27	0.03	0.11	547.19	14.64	532.55
0+180.00	0.37	17.81	0.66	5.42	565.00	20.06	544.94
0+189.29	1.21	7.36	0.15	3.74	572.36	23.80	548.55
0+200.00	7.31	46.01	0.11	1.33	618.37	25.14	593.23
0+214.16	11.82	137.11	0.24	2.47	755.48	27.61	727.87
0+220.00	14.96	69.39	0.38	1.83	824.86	29.45	795.42
0+231.97	10.80	141.73	0.34	4.32	966.59	33.76	932.83
0+240.00	14.98	94.18	0.06	1.61	1,060.78	35.37	1,025.41
0+249.77	21.96	165.74	0.00	0.29	1,226.51	35.66	1,190.85
0+260.00	23.99	255.74	0.00	0.00	1,482.26	35.66	1,446.60
0+273.72	18.03	313.66	0.00	0.00	1,795.92	35.66	1,760.26
0+280.00	17.32	119.60	0.00	0.00	1,915.52	35.66	1,879.86
0+297.67	8.11	238.46	0.00	0.00	2,153.98	35.66	2,118.32
0+300.00	13.51	24.08	0.00	0.00	2,178.06	35.66	2,142.39
0+320.00	3.77	172.87	0.00	0.00	2,350.93	35.66	2,315.27
0+334.73	0.22	29.39	0.86	6.33	2,380.32	41.99	2,338.32
0+340.00	0.86	2.93	0.22	2.75	2,383.25	44.74	2,338.51
0+360.00	2.32	32.05	0.02	2.32	2,415.30	47.06	2,368.24
0+362.16	2.25	4.95	0.02	0.04	2,420.25	47.10	2,373.15
0+380.00	0.79	27.25	0.20	1.95	2,447.51	49.05	2,398.45



0+389.59	0.44	5.98	0.31	2.42	2,453.49	51.47	2,402.02
0+400.00	0.69	5.84	0.38	3.58	2,459.33	55.05	2,404.28
0+420.00	0.79	14.81	0.44	8.20	2,474.14	63.25	2,410.89
0+440.00	0.09	8.88	0.30	7.37	2,483.01	70.61	2,412.40
0+460.00	0.13	2.29	0.48	7.80	2,485.30	78.41	2,406.89
0+480.00	0.91	10.49	0.31	7.97	2,495.79	86.38	2,409.41
0+500.00	3.22	41.37	0.03	3.43	2,537.16	89.81	2,447.35
0+520.00	5.09	83.12	0.00	0.28	2,620.28	90.10	2,530.19
0+540.00	6.99	120.83	0.00	0.00	2,741.12	90.10	2,651.02
0+560.00	3.80	107.97	0.00	0.00	2,849.09	90.10	2,758.99
0+580.00	3.58	73.81	0.00	0.00	2,922.90	90.10	2,832.81
0+600.00	2.83	64.07	0.00	0.00	2,986.97	90.10	2,896.88
0+620.00	2.11	49.36	0.01	0.13	3,036.33	90.23	2,946.10
0+637.52	1.40	30.69	0.05	0.58	3,067.02	90.81	2,976.21
0+640.00	1.31	3.36	0.08	0.16	3,070.38	90.97	2,979.41
0+660.00	1.37	26.80	0.11	1.82	3,097.18	92.79	3,004.39
0+660.05	1.37	0.06	0.11	0.00	3,097.24	92.79	3,004.45
0+680.00	2.35	37.21	0.01	1.15	3,134.45	93.94	3,040.50
0+682.58	2.17	5.83	0.01	0.03	3,140.28	93.97	3,046.31
0+697.18	1.17	24.39	0.20	1.57	3,164.67	95.54	3,069.12
0+700.00	0.98	3.02	0.32	0.73	3,167.69	96.27	3,071.42
0+716.06	0.67	13.37	0.56	6.86	3,181.06	103.13	3,077.93
0+720.00	0.67	2.68	0.52	2.02	3,183.74	105.15	3,078.59
0+734.94	0.88	11.71	0.22	5.23	3,195.44	110.38	3,085.06
0+740.00	1.30	5.53	0.14	0.89	3,200.97	111.28	3,089.69
0+760.00	1.96	32.62	0.05	1.88	3,233.60	113.16	3,120.43
0+778.09	2.16	37.35	0.05	0.87	3,270.95	114.03	3,156.92
0+780.00	2.17	4.15	0.05	0.09	3,275.10	114.12	3,160.97
0+800.00	1.80	39.86	0.14	1.84	3,314.96	115.96	3,198.99
0+820.00	1.44	32.59	0.80	9.23	3,347.55	125.19	3,222.36
0+821.24	1.62	1.90	0.85	1.02	3,349.45	126.21	3,223.24
0+840.00	4.11	53.77	0.00	7.92	3,403.21	134.13	3,269.09
0+842.81	4.40	11.94	0.00	0.00	3,415.15	134.13	3,281.02
0+860.00	2.72	61.14	0.00	0.02	3,476.29	134.16	3,342.13
0+864.37	2.35	11.07	0.05	0.11	3,487.36	134.26	3,353.10
0+880.00	0.70	23.59	0.69	5.94	3,510.95	140.21	3,370.74
0+897.72	0.09	7.00	0.92	14.59	3,517.95	154.80	3,363.15
0+900.00	0.03	0.14	0.97	2.18	3,518.08	156.97	3,361.11
0+920.00	0.00	0.29	3.03	40.06	3,518.37	197.04	3,321.34
0+931.06	0.00	0.00	3.95	38.73	3,518.37	235.77	3,282.60
0+940.00	0.00	0.00	3.71	34.23	3,518.37	270.00	3,248.38
0+960.00	0.68	6.85	0.30	40.11	3,525.22	310.10	3,215.12
0+967.50	3.48	15.64	0.00	1.13	3,540.86	311.24	3,229.62
0+980.00	7.37	67.80	0.00	0.00	3,608.66	311.24	3,297.42
0+985.31	8.34	41.73	0.00	0.00	3,650.39	311.24	3,339.15
1+000.00	8.93	126.67	0.02	0.14	3,777.06	311.38	3,465.68



1+003.12	9.09	28.12	0.16	0.28	3,805.18	311.66	3,493.52
1+011.99	9.62	84.93	0.00	0.66	3,890.11	312.32	3,577.79
1+020.00	8.05	71.76	0.00	0.00	3,961.87	312.32	3,649.55
1+020.86	7.97	6.95	0.00	0.00	3,968.82	312.32	3,656.50
1+040.00	6.32	136.56	0.00	0.00	4,105.38	312.32	3,793.06
1+046.04	6.52	38.79	0.00	0.00	4,144.17	312.32	3,831.85
1+060.00	7.68	99.13	0.00	0.00	4,243.30	312.32	3,930.98
1+071.23	9.50	96.40	0.00	0.00	4,339.70	312.32	4,027.38
1+080.00	12.28	95.40	0.00	0.00	4,435.09	312.32	4,122.77
1+100.00	18.35	305.94	0.00	0.00	4,741.03	312.32	4,428.71
1+104.61	19.15	86.46	0.00	0.00	4,827.50	312.32	4,515.18
1+120.00	16.24	271.92	0.00	0.00	5,099.42	312.32	4,787.10
1+138.00	7.85	216.48	0.00	0.00	5,315.90	312.32	5,003.58
1+140.00	6.89	14.67	0.00	0.00	5,330.57	312.32	5,018.25
1+153.80	3.11	69.43	0.01	0.09	5,400.00	312.41	5,087.59
1+160.00	1.14	13.32	0.16	0.51	5,413.32	312.92	5,100.40
1+169.61	0.02	5.67	2.18	11.09	5,418.99	324.01	5,094.98
1+176.70	0.02	0.19	2.88	16.41	5,419.18	340.43	5,078.75
1+180.00	0.08	0.19	2.56	8.19	5,419.37	348.62	5,070.75
1+183.80	0.06	0.29	3.04	9.73	5,419.66	358.34	5,061.32
1+200.00	0.00	0.46	5.99	73.13	5,420.12	431.48	4,988.64
1+220.00	0.00	0.00	9.65	156.46	5,420.12	587.93	4,832.19
1+240.00	0.00	0.00	8.95	186.06	5,420.12	774.00	4,646.13
1+242.40	0.00	0.00	8.54	21.01	5,420.12	795.01	4,625.11
1+253.33	0.00	0.00	7.04	84.83	5,420.12	879.84	4,540.28
1+260.00	0.00	0.00	6.29	44.16	5,420.12	924.00	4,496.13
1+264.26	0.00	0.00	5.86	25.71	5,420.12	949.71	4,470.41
1+271.58	1.10	4.25	4.48	37.30	5,424.38	987.01	4,437.36
1+278.90	0.70	7.01	3.41	28.21	5,431.39	1,015.22	4,416.17
1+280.00	0.52	0.67	3.27	3.67	5,432.06	1,018.89	4,413.17
1+300.00	0.30	8.26	0.57	38.43	5,440.32	1,057.31	4,383.01
1+304.28	1.56	3.98	0.71	2.76	5,444.31	1,060.07	4,384.24
1+313.28	3.88	25.31	0.49	5.18	5,469.62	1,065.25	4,404.36
1+320.00	4.20	28.11	0.41	2.89	5,497.72	1,068.15	4,429.58
1+322.27	4.06	9.72	0.49	0.98	5,507.45	1,069.13	4,438.32
1+334.32	1.10	31.70	1.25	10.38	5,539.14	1,079.51	4,459.64
1+340.00	0.00	3.12	2.69	11.19	5,542.27	1,090.69	4,451.57
1+346.37	0.00	0.01	2.42	16.27	5,542.28	1,106.96	4,435.32
1+360.00	6.66	45.27	0.02	16.65	5,587.55	1,123.61	4,463.94
1+378.06	8.45	136.50	0.00	0.15	5,724.05	1,123.76	4,600.30
1+380.00	8.31	15.56	0.00	0.00	5,739.61	1,123.76	4,615.86
1+391.11	2.46	58.79	0.05	0.23	5,798.40	1,123.99	4,674.42
1+400.00	0.11	11.61	1.40	6.03	5,810.02	1,130.02	4,680.00
1+404.17	0.00	0.25	2.33	7.38	5,810.27	1,137.40	4,672.87
1+420.00	0.43	3.31	0.91	25.58	5,813.57	1,162.98	4,650.60
1+424.57	0.08	1.12	1.56	5.70	5,814.70	1,168.68	4,646.01



1+440.00	0.00	0.58	2.23	29.23	5,815.28	1,197.91	4,617.37
1+444.98	0.00	0.00	2.36	11.38	5,815.28	1,209.28	4,606.00
1+460.00	0.65	4.81	0.52	21.63	5,820.09	1,230.91	4,589.18
1+480.00	2.71	33.30	0.03	5.46	5,853.39	1,236.37	4,617.02
1+482.44	3.38	7.45	0.09	0.14	5,860.84	1,236.51	4,624.33
1+500.00	3.92	63.79	0.03	1.04	5,924.63	1,237.55	4,687.08
1+519.91	2.98	68.60	0.00	0.29	5,993.22	1,237.84	4,755.38
1+520.00	2.99	0.23	0.00	0.00	5,993.45	1,237.84	4,755.61
1+540.00	4.85	78.59	1.39	13.47	6,072.04	1,251.31	4,820.73
1+554.96	9.00	103.92	0.00	10.08	6,175.96	1,261.39	4,914.58
1+560.00	9.65	47.06	0.00	0.00	6,223.03	1,261.39	4,961.64
1+580.00	12.24	219.34	0.00	0.00	6,442.37	1,261.39	5,180.98
1+590.01	12.44	123.90	0.00	0.00	6,566.27	1,261.39	5,304.88
1+600.00	15.48	142.43	0.00	0.00	6,708.70	1,261.39	5,447.32
1+600.32	15.63	4.98	0.00	0.00	6,713.68	1,261.39	5,452.29
1+610.63	19.53	183.46	0.00	0.00	6,897.13	1,261.39	5,635.75
1+620.00	16.58	168.91	0.00	0.00	7,066.05	1,261.39	5,804.66
1+632.66	13.02	187.37	0.00	0.00	7,253.42	1,261.39	5,992.04
1+640.00	12.02	91.59	0.00	0.00	7,345.01	1,261.39	6,083.62
1+654.68	9.35	155.89	0.00	0.00	7,500.90	1,261.39	6,239.51
1+660.00	8.44	47.27	0.00	0.00	7,548.17	1,261.39	6,286.78
1+668.23	10.22	76.79	0.00	0.00	7,624.96	1,261.39	6,363.58
1+677.61	12.24	107.97	0.00	0.00	7,732.93	1,261.39	6,471.54
1+680.00	12.07	29.77	0.00	0.00	7,762.70	1,261.39	6,501.31
1+686.99	10.02	79.35	0.00	0.00	7,842.05	1,261.39	6,580.67
1+697.69	5.96	85.47	0.00	0.00	7,927.52	1,261.39	6,666.13
1+700.00	5.23	12.93	0.01	0.01	7,940.45	1,261.40	6,679.05
1+715.69	3.41	67.79	0.00	0.10	8,008.24	1,261.50	6,746.74
1+720.00	3.58	15.07	0.00	0.00	8,023.32	1,261.50	6,761.82
1+733.69	1.57	35.25	0.69	4.76	8,058.57	1,266.26	6,792.31
1+740.00	2.44	12.69	0.32	3.19	8,071.27	1,269.44	6,801.82
1+758.85	1.69	39.12	0.09	3.78	8,110.39	1,273.23	6,837.16
1+760.00	1.69	1.96	0.07	0.09	8,112.34	1,273.32	6,839.03
1+780.00	1.68	33.65	0.00	0.66	8,145.99	1,273.98	6,872.01
1+784.00	1.31	5.94	0.01	0.01	8,151.93	1,273.99	6,877.94
1+800.00	1.76	24.35	0.06	0.50	8,176.29	1,274.49	6,901.80
1+800.94	2.05	1.79	0.03	0.04	8,178.07	1,274.53	6,903.54
1+817.87	3.33	45.43	0.00	0.29	8,223.50	1,274.82	6,948.68
1+820.00	3.90	7.71	0.00	0.00	8,231.21	1,274.82	6,956.39
1+829.72	6.14	48.72	0.00	0.00	8,279.93	1,274.82	7,005.11
1+840.00	8.27	73.28	0.00	0.00	8,353.20	1,274.82	7,078.39
1+841.56	9.33	13.47	0.00	0.00	8,366.67	1,274.82	7,091.86
1+857.64	7.31	132.78	0.00	0.00	8,499.45	1,274.82	7,224.63
1+860.00	7.41	17.37	0.00	0.00	8,516.82	1,274.82	7,242.00
1+873.72	8.69	109.92	0.00	0.00	8,626.73	1,274.82	7,351.92
1+880.00	9.78	58.37	0.00	0.00	8,685.10	1,274.82	7,410.28



1+890.04	8.86	93.91	0.00	0.00	8,779.01	1,274.82	7,504.19
1+900.00	7.33	80.95	0.00	0.00	8,859.95	1,274.82	7,585.14
1+906.36	5.21	39.85	0.00	0.00	8,899.81	1,274.82	7,624.99
1+920.00	0.65	40.62	0.88	5.78	8,940.42	1,280.59	7,659.83
1+928.66	0.01	2.93	1.78	11.34	8,943.36	1,291.93	7,651.42
1+940.00	0.00	0.08	2.56	24.49	8,943.44	1,316.42	7,627.02
1+950.96	0.00	0.00	4.03	36.13	8,943.44	1,352.55	7,590.89
1+960.00	0.00	0.00	5.51	43.20	8,943.44	1,395.75	7,547.69
1+980.00	0.00	0.00	4.88	103.78	8,943.44	1,499.54	7,443.90
1+986.75	0.00	0.00	5.36	34.39	8,943.44	1,533.93	7,409.51
2+000.00	0.00	0.00	6.20	76.29	8,943.44	1,610.22	7,333.22
2+020.00	0.92	9.40	3.42	95.86	8,952.84	1,706.08	7,246.77
2+022.55	0.73	2.11	3.27	8.51	8,954.95	1,714.59	7,240.37
2+040.00	1.87	22.14	2.16	47.65	8,977.10	1,762.24	7,214.86
2+054.39	0.89	19.20	2.57	34.35	8,996.29	1,796.59	7,199.71
2+060.00	0.38	3.44	3.10	16.05	8,999.73	1,812.64	7,187.09
2+080.00	0.00	3.68	3.73	68.71	9,003.41	1,881.35	7,122.07
2+086.23	0.00	0.00	3.39	22.30	9,003.41	1,903.64	7,099.77
2+100.00	0.00	0.00	2.70	41.97	9,003.41	1,945.62	7,057.80
2+112.68	0.00	0.02	2.82	34.99	9,003.43	1,980.61	7,022.82
2+120.00	0.03	0.11	2.43	19.22	9,003.54	1,999.83	7,003.72
2+139.13	2.43	23.53	0.00	23.27	9,027.07	2,023.10	7,003.97
2+140.00	2.58	2.21	0.00	0.00	9,029.28	2,023.10	7,006.18
2+160.00	4.44	70.15	0.00	0.00	9,099.42	2,023.10	7,076.33
2+180.00	4.54	89.75	0.00	0.00	9,189.17	2,023.10	7,166.07
2+200.00	4.33	88.71	0.00	0.00	9,277.88	2,023.10	7,254.79
2+220.00	4.21	85.42	0.00	0.00	9,363.31	2,023.10	7,340.21
2+240.00	2.97	71.79	0.00	0.00	9,435.10	2,023.10	7,412.00
2+260.00	2.42	53.94	0.00	0.00	9,489.04	2,023.10	7,465.94
2+263.45	2.31	8.17	0.00	0.00	9,497.20	2,023.10	7,474.11
2+280.00	1.49	31.50	0.04	0.32	9,528.71	2,023.42	7,505.29
2+281.38	1.41	2.01	0.05	0.06	9,530.71	2,023.48	7,507.24
2+299.32	0.42	16.48	0.20	2.27	9,547.19	2,025.74	7,521.45
2+300.00	0.44	0.29	0.19	0.14	9,547.49	2,025.88	7,521.61
2+320.00	0.65	10.89	0.08	2.68	9,558.38	2,028.56	7,529.82
2+340.00	2.79	34.40	0.01	0.83	9,592.78	2,029.40	7,563.38
2+352.03	3.32	36.75	0.00	0.05	9,629.53	2,029.45	7,600.08
2+360.00	3.14	25.76	0.00	0.01	9,655.29	2,029.46	7,625.83
2+380.00	2.79	59.32	0.00	0.00	9,714.61	2,029.46	7,685.15
2+400.00	2.27	50.58	0.11	1.06	9,765.18	2,030.51	7,734.67
2+404.74	2.47	11.23	0.08	0.44	9,776.41	2,030.96	7,745.46





### Nota de serviço

Lado Esquerdo			Eixo						Lado Direito		
TOPO DO BORDO			Estaca	Pontos Notáveis da Geometria Horizontal	Pontos Notáveis da Geometria Vertical	Cota Projeto	Cota Terreno	Cota Vermelha	TOPO DO PAVIMENTO		
Afast. (m)	Cota (m)	Incl. (%)							Afast. (m)	Cota (m)	Incl. (%)
-3.300	545.918	-2.50	0+0.000		PCV	546.000	546.036	-0.036	3.300	545.918	-2.50
-3.300	544.983	-2.50	1+0.000			545.065	544.754	0.312	3.300	544.983	-2.50
-3.300	544.150	-2.50	1+16.843	PC		544.233	544.028	0.205	3.300	544.150	-2.50
-3.300	543.987	-2.50	2+0.000			544.069	543.993	0.076	3.300	543.987	-2.50
-3.300	543.494	-2.50	2+9.197			543.577	543.655	-0.078	3.300	543.494	-2.50
-3.300	542.889	-2.50	3+0.000			542.972	542.907	0.064	3.300	542.889	-2.50
-3.300	542.800	-2.50	3+1.550	PCC		542.882	542.821	0.062	3.300	542.800	-2.50
-3.300	541.912	-2.50	3+16.434			541.994	541.980	0.014	3.300	541.912	-2.50
-3.300	541.690	-2.50	4+0.000			541.773	541.759	0.014	3.300	541.690	-2.50
-3.300	540.967	-2.50	4+11.318	PCR		541.050	541.004	0.046	3.300	540.967	-2.50
-3.300	540.390	-2.50	5+0.000			540.473	540.491	-0.018	3.300	540.390	-2.50
-3.300	540.379	-2.50	5+0.175			540.461	540.480	-0.019	3.300	540.379	-2.50
-3.300	539.770	-2.50	5+9.032	PCC		539.853	539.872	-0.020	3.300	539.770	-2.50
-3.300	538.989	-2.50	6+0.000			539.072	538.937	0.135	3.300	538.989	-2.50
-3.300	538.921	-2.50	6+0.934			539.004	538.850	0.153	3.300	538.921	-2.50
-3.300	538.037	-2.50	6+12.835	PCC		538.119	538.011	0.108	3.300	538.037	-2.50
-3.300	537.487	-2.50	7+0.000			537.569	537.471	0.098	3.300	537.487	-2.50
-3.300	536.965	-2.50	7+6.644			537.048	536.957	0.091	3.300	536.965	-2.50
-3.300	535.883	-2.50	8+0.000			535.966	535.719	0.246	3.300	535.883	-2.50
-3.300	535.846	-2.50	8+0.452	PT		535.928	535.679	0.249	3.300	535.846	-2.50
-3.300	535.515	-2.50	8+4.421	PC		535.598	535.323	0.275	3.300	535.515	-2.50
-3.300	534.178	-2.50	9+0.000			534.261	533.891	0.370	3.300	534.178	-2.50
-3.300	533.352	-2.50	9+9.290			533.434	533.152	0.282	3.300	533.352	-2.50



-3.300	532.372	-2.50	10+0.000			532.455	532.137	0.317	3.300	532.372	-2.50
-3.300	531.032	-2.50	10+14.159	PCR	PTV	531.115	530.689	0.426	3.300	531.032	-2.50
-3.300	530.465	-2.50	11+0.000			530.548	530.091	0.456	3.300	530.465	-2.50
-3.300	529.301	-2.50	11+11.966			529.383	528.957	0.427	3.300	529.301	-2.50
-3.300	528.519	-2.50	12+0.000			528.601	528.350	0.252	3.300	528.519	-2.50
-3.300	527.568	-2.50	12+9.774	PCR		527.650	527.587	0.063	3.300	527.568	-2.50
-3.300	526.572	-2.50	13+0.000			526.655	526.859	-0.205	3.300	526.572	-2.50
-3.300	525.236	-2.50	13+13.723			525.319	525.618	-0.299	3.300	525.236	-2.50
-3.300	524.626	-2.50	14+0.000			524.708	524.919	-0.211	3.300	524.626	-2.50
-3.300	522.905	-2.50	14+17.673	PT		522.988	523.255	-0.267	3.300	522.905	-2.50
-3.300	522.679	-2.50	15+0.000		PCV	522.761	523.008	-0.246	3.300	522.679	-2.50
-3.300	520.920	-2.50	16+0.000			521.002	520.850	0.152	3.300	520.920	-2.50
-3.300	519.906	-2.50	16+14.726	PC		519.988	519.538	0.451	3.300	519.906	-2.50
-3.300	519.601	-2.50	17+0.000			519.683	519.381	0.302	3.300	519.601	-2.50
-3.300	518.723	-2.50	18+0.000			518.806	518.713	0.093	3.300	518.723	-2.50
-3.300	518.655	-2.50	18+2.160		PTV	518.737	518.637	0.100	3.300	518.655	-2.50
-3.300	518.286	-2.50	19+0.000			518.369	518.066	0.302	3.300	518.286	-2.50
-4.405	518.139	-2.50	19+9.594	PT		518.249	517.861	0.388	3.300	518.166	-2.50
-6.077	517.967	-2.50	20+0.000			518.119	517.668	0.451	3.300	518.036	-2.50
-6.357	517.710	-2.50	21+0.000			517.869	517.408	0.461	3.300	517.786	-2.50
-3.977	517.520	-2.50	22+0.000			517.619	517.201	0.419	3.300	517.537	-2.50
-3.300	517.287	-2.50	23+0.000			517.369	516.965	0.404	3.300	517.287	-2.50
-3.300	517.037	-2.50	24+0.000			517.120	516.835	0.285	3.300	517.037	-2.50
-3.300	516.787	-2.50	25+0.000			516.870	516.764	0.106	4.520	516.757	-2.50
-3.300	516.538	-2.50	26+0.000			516.620	516.602	0.018	6.345	516.461	-2.50
-3.300	516.288	-2.50	27+0.000			516.370	516.481	-0.110	5.516	516.232	-2.50
-3.300	516.038	-2.50	28+0.000			516.121	516.169	-0.049	3.300	516.038	-2.50
-3.300	515.788	-2.50	29+0.000		PCV	515.871	515.886	-0.016	3.300	515.788	-2.50
-3.300	515.549	-2.50	30+0.000			515.631	515.604	0.027	3.300	515.549	-2.50



-3.300	515.336	-2.50	31+0.000			515.418	515.301	0.117	3.300	515.336	-2.50
-3.300	515.171	-2.50	31+17.516	PC		515.253	515.042	0.212	3.300	515.171	-2.50
-3.300	515.149	-2.50	32+0.000			515.232	515.008	0.224	3.300	515.149	-2.50
-3.300	514.989	-2.50	33+0.000			515.071	514.858	0.214	3.300	514.989	-2.50
-3.300	514.988	-2.50	33+0.047			515.071	514.858	0.213	3.300	514.988	-2.50
-3.300	514.855	-2.50	34+0.000			514.937	514.791	0.146	3.300	514.855	-2.50
-3.300	514.840	-2.50	34+2.577	PT		514.922	514.759	0.163	3.300	514.840	-2.50
-3.300	514.761	-2.50	34+17.183	PC		514.844	514.556	0.288	3.300	514.761	-2.50
-3.300	514.748	-2.50	35+0.000			514.830	514.515	0.315	3.300	514.748	-2.50
-3.300	514.681	-2.50	35+16.059			514.763	514.444	0.319	3.300	514.681	-2.50
-3.300	514.667	-2.50	36+0.000			514.749	514.445	0.304	3.300	514.667	-2.50
-3.300	514.623	-2.50	36+14.936	PCC		514.706	514.415	0.291	3.300	514.623	-2.50
-3.300	514.612	-2.50	37+0.000			514.695	514.466	0.228	3.300	514.612	-2.50
-3.300	514.584	-2.50	38+0.000			514.667	514.526	0.141	3.300	514.584	-2.50
-3.300	514.582	-2.50	38+18.088			514.664	514.545	0.120	3.300	514.582	-2.50
-3.300	514.583	-2.50	39+0.000		PTV	514.665	514.543	0.122	3.300	514.583	-2.50
-3.300	514.597	-2.50	40+0.000			514.680	514.513	0.166	3.300	514.597	-2.50
-3.300	514.612	-2.50	41+0.000			514.694	514.485	0.209	3.300	514.612	-2.50
-3.300	514.613	-2.50	41+1.240	PCR		514.695	514.510	0.185	3.300	514.613	-2.50
-3.300	514.626	-2.50	42+0.000			514.709	514.690	0.018	3.300	514.626	-2.50
-3.300	514.628	-2.50	42+2.805			514.711	514.710	0.001	3.300	514.628	-2.50
-3.300	514.641	-2.50	43+0.000			514.723	514.577	0.146	3.300	514.641	-2.50
-3.300	514.644	-2.50	43+4.371	PCC		514.727	514.587	0.139	3.300	514.644	-2.50
-3.300	514.656	-2.50	44+0.000		PCV	514.738	514.424	0.314	3.300	514.656	-2.50
-3.300	514.756	-2.50	44+17.716			514.839	514.360	0.478	3.300	514.756	-2.50
-3.300	514.788	-2.50	45+0.000			514.870	514.359	0.511	3.300	514.788	-2.50
-3.300	515.254	-2.50	46+0.000			515.336	514.623	0.713	3.300	515.254	-2.50
-3.300	515.657	-2.50	46+11.061	PT		515.739	514.923	0.816	3.300	515.657	-2.50
-3.300	516.058	-2.50	47+0.000			516.140	515.405	0.736	3.300	516.058	-2.50



-3.300	517.200	-2.50	48+0.000			517.283	516.947	0.336	3.300	517.200	-2.50
-3.300	517.716	-2.50	48+7.503	PC		517.799	517.836	-0.037	3.300	517.716	-2.50
-3.300	518.681	-2.50	49+0.000			518.764	519.247	-0.483	3.300	518.681	-2.50
-3.300	519.132	-2.50	49+5.313		PTV	519.214	519.845	-0.630	3.300	519.132	-2.50
-3.300	520.496	-2.50	50+0.000			520.579	521.284	-0.705	3.300	520.496	-2.50
-3.300	520.798	-2.50	50+3.122	PCR		520.880	521.589	-0.709	3.300	520.798	-2.50
-3.300	521.654	-2.50	50+11.990			521.737	522.468	-0.731	3.300	521.654	-2.50
-3.300	522.428	-2.50	51+0.000			522.511	523.009	-0.499	3.300	522.428	-2.50
-3.300	522.511	-2.50	51+0.857	PCR		522.594	523.065	-0.471	3.300	522.511	-2.50
-3.300	524.361	-2.50	52+0.000			524.443	524.779	-0.336	3.300	524.361	-2.50
-3.300	524.944	-2.50	52+6.042		PCV	525.027	525.391	-0.364	3.300	524.944	-2.50
-3.300	526.293	-2.50	53+0.000			526.375	526.752	-0.377	3.300	526.293	-2.50
-3.300	527.378	-2.50	53+11.227	PCC		527.461	528.028	-0.568	3.300	527.378	-2.50
-3.300	528.226	-2.50	54+0.000			528.309	529.120	-0.811	3.300	528.226	-2.50
-3.300	530.161	-2.50	55+0.000			530.243	531.400	-1.157	3.300	530.161	-2.50
-3.300	530.607	-2.50	55+4.612			530.689	531.891	-1.202	3.300	530.607	-2.50
-3.300	532.096	-2.50	56+0.000			532.179	533.194	-1.015	3.300	532.096	-2.50
-3.300	533.839	-2.50	56+17.997	PCR		533.921	534.328	-0.406	3.300	533.839	-2.50
-3.300	534.033	-2.50	57+0.000			534.115	534.423	-0.308	3.300	534.033	-2.50
-3.300	535.370	-2.50	57+13.802			535.452	535.371	0.081	3.300	535.370	-2.50
-3.300	535.971	-2.50	58+0.000			536.053	535.763	0.290	3.300	535.971	-2.50
-3.300	536.902	-2.50	58+9.608	PCC		536.984	536.350	0.634	3.300	536.902	-2.50
-3.300	537.590	-2.50	58+16.703			537.672	537.017	0.655	3.300	537.590	-2.50
-3.300	537.909	-2.50	59+0.000			537.992	537.314	0.678	3.300	537.909	-2.50
-3.300	538.278	-2.50	59+3.798	PT		538.360	537.611	0.749	3.300	538.278	-2.50
-3.300	539.849	-2.50	60+0.000			539.932	538.803	1.128	3.300	539.849	-2.50
-3.300	541.791	-2.50	61+0.000			541.873	540.501	1.372	3.300	541.791	-2.50
-3.300	543.733	-2.50	62+0.000			543.815	542.448	1.367	3.300	543.733	-2.50
-3.300	543.966	-2.50	62+2.403	PC	PTV	544.049	542.683	1.366	3.300	543.966	-2.50



-3.300	545.028	-2.50	62+13.331			545.110	543.832	1.278	3.300	545.028	-2.50
-3.300	545.676	-2.50	63+0.000			545.758	544.567	1.191	3.300	545.676	-2.50
-3.300	546.090	-2.50	63+4.260	PCC		546.172	545.047	1.125	3.300	546.090	-2.50
-3.300	546.801	-2.50	63+11.581			546.884	545.914	0.970	3.300	546.801	-2.50
-3.300	547.513	-2.50	63+18.903	PT		547.595	546.804	0.792	3.300	547.513	-2.50
-3.300	547.619	-2.50	64+0.000			547.702	546.931	0.771	3.300	547.619	-2.50
-3.300	549.563	-2.50	65+0.000			549.645	549.249	0.396	3.300	549.563	-2.50
-3.300	549.979	-2.50	65+4.282	PC		550.061	549.745	0.316	3.300	549.979	-2.50
-3.300	550.852	-2.50	65+13.275			550.935	550.702	0.232	3.300	550.852	-2.50
-3.300	551.506	-2.50	66+0.000			551.588	551.176	0.413	3.300	551.506	-2.50
-3.300	551.726	-2.50	66+2.269	PCC		551.809	551.371	0.438	3.300	551.726	-2.50
-3.300	552.897	-2.50	66+14.319		PCV	552.980	552.491	0.489	3.300	552.897	-2.50
-3.300	553.448	-2.50	67+0.000			553.531	552.840	0.691	3.300	553.448	-2.50
-3.300	553.996	-2.50	67+6.370	PT		554.079	553.466	0.613	3.300	553.996	-2.50
-3.300	554.778	-2.50	68+0.000			554.861	554.890	-0.030	3.300	554.778	-2.50
-3.300	554.998	-2.50	68+18.060	PC		555.080	555.462	-0.382	3.300	554.998	-2.50
-3.300	554.966	-2.50	69+0.000			555.048	555.403	-0.354	3.300	554.966	-2.50
-3.300	554.576	-2.50	69+11.113			554.658	554.508	0.150	3.300	554.576	-2.50
-3.300	554.010	-2.50	70+0.000			554.093	553.541	0.552	3.300	554.010	-2.50
-3.300	553.668	-2.50	70+4.165	PCC	PTV	553.750	553.109	0.641	3.300	553.668	-2.50
-3.300	552.170	-2.50	71+0.000		PCV	552.252	551.755	0.498	3.300	552.170	-2.50
-3.300	551.735	-2.50	71+4.570			551.818	551.204	0.614	3.300	551.735	-2.50
-3.300	550.272	-2.50	72+0.000			550.354	549.705	0.649	3.300	550.272	-2.50
-3.300	549.801	-2.50	72+4.975	PCC		549.883	549.228	0.656	3.300	549.801	-2.50
-3.300	548.382	-2.50	73+0.000			548.464	548.011	0.453	3.300	548.382	-2.50
-3.300	546.500	-2.50	74+0.000			546.583	546.458	0.125	3.300	546.500	-2.50
-3.300	546.271	-2.50	74+2.444			546.353	546.372	-0.019	3.300	546.271	-2.50
-3.300	544.627	-2.50	75+0.000			544.709	544.899	-0.190	3.300	544.627	-2.50
-3.300	542.769	-2.50	75+19.914	PCR		542.852	542.731	0.121	3.300	542.769	-2.50



-3.300	542.761	-2.50	76+0.000			542.844	542.724	0.120	3.300	542.761	-2.50
-3.300	540.904	-2.50	77+0.000			540.987	541.359	-0.373	3.300	540.904	-2.50
-3.300	539.520	-2.50	77+14.960			539.603	540.286	-0.684	3.300	539.520	-2.50
-3.300	539.055	-2.50	78+0.000			539.138	539.885	-0.747	3.300	539.055	-2.50
-3.300	537.215	-2.50	79+0.000			537.297	538.309	-1.012	3.300	537.215	-2.50
-3.300	536.297	-2.50	79+10.007	PCC		536.379	537.355	-0.976	3.300	536.297	-2.50
-3.300	535.382	-2.50	80+0.000			535.465	536.784	-1.320	3.300	535.382	-2.50
-3.300	535.353	-2.50	80+0.320			535.435	536.768	-1.333	3.300	535.353	-2.50
-3.300	534.411	-2.50	80+10.633	PCR		534.494	536.200	-1.706	3.300	534.411	-2.50
-3.300	533.558	-2.50	81+0.000		PTV	533.640	534.925	-1.285	3.300	533.558	-2.50
-3.300	532.406	-2.50	81+12.659			532.488	533.474	-0.986	3.300	532.406	-2.50
-3.300	531.738	-2.50	82+0.000			531.820	532.600	-0.780	3.300	531.738	-2.50
-3.300	530.401	-2.50	82+14.685	PT		530.484	530.979	-0.495	3.300	530.401	-2.50
-3.300	529.918	-2.50	83+0.000			530.000	530.413	-0.413	3.300	529.918	-2.50
-3.300	529.168	-2.50	83+8.234	PC		529.251	529.449	-0.199	3.300	529.168	-2.50
-3.300	528.315	-2.50	83+17.614			528.397	528.530	-0.133	3.300	528.315	-2.50
-3.300	528.098	-2.50	84+0.000			528.180	528.295	-0.115	3.300	528.098	-2.50
-3.300	527.461	-2.50	84+6.994	PT		527.544	527.597	-0.054	3.300	527.461	-2.50
-3.300	526.488	-2.50	84+17.690	PC		526.570	526.520	0.051	3.300	526.488	-2.50
-3.300	526.277	-2.50	85+0.000			526.360	526.295	0.065	3.300	526.277	-2.50
-3.300	524.850	-2.50	85+15.689			524.932	524.877	0.055	3.300	524.850	-2.50
-3.300	524.457	-2.50	86+0.000			524.540	524.528	0.012	3.300	524.457	-2.50
-3.300	523.212	-2.50	86+13.689	PCC		523.294	523.003	0.291	3.300	523.212	-2.50
-3.300	522.637	-2.50	87+0.000			522.720	522.549	0.171	3.300	522.637	-2.50
-3.300	520.922	-2.50	87+18.845			521.005	520.903	0.102	3.300	520.922	-2.50
-3.300	520.817	-2.50	88+0.000			520.900	520.775	0.125	3.300	520.817	-2.50
-3.300	518.997	-2.50	89+0.000			519.079	518.729	0.350	3.300	518.997	-2.50
-3.300	518.633	-2.50	89+4.002	PCC		518.715	518.352	0.363	3.300	518.633	-2.50
-3.300	517.177	-2.50	90+0.000			517.259	516.877	0.382	3.300	517.177	-2.50



-3.300	517.091	-2.50	90+0.938			517.174	516.802	0.372	3.300	517.091	-2.50
-3.300	515.550	-2.50	90+17.875	PCC		515.633	515.601	0.032	3.300	515.550	-2.50
-3.300	515.357	-2.50	91+0.000			515.439	515.445	-0.006	3.300	515.357	-2.50
-3.300	514.472	-2.50	91+9.719			514.555	514.738	-0.184	3.300	514.472	-2.50
-3.300	513.537	-2.50	92+0.000			513.619	513.954	-0.335	3.300	513.537	-2.50
-3.300	513.394	-2.50	92+1.564	PCC		513.477	513.824	-0.347	3.300	513.394	-2.50
-3.300	511.931	-2.50	92+17.641			512.014	512.241	-0.228	3.300	511.931	-2.50
-3.300	511.716	-2.50	93+0.000		PCV	511.799	512.047	-0.248	3.300	511.716	-2.50
-3.300	510.501	-2.50	93+13.718	PCR		510.584	510.908	-0.324	3.300	510.501	-2.50
-3.300	509.976	-2.50	94+0.000			510.059	510.369	-0.310	3.300	509.976	-2.50
-3.300	509.180	-2.50	94+10.037			509.262	509.547	-0.285	3.300	509.180	-2.50
-3.300	508.440	-2.50	95+0.000			508.523	508.581	-0.058	3.300	508.440	-2.50
-3.300	507.996	-2.50	95+6.356	PCC		508.078	508.100	-0.021	3.300	507.996	-2.50
-3.300	507.111	-2.50	96+0.000			507.194	506.866	0.328	3.300	507.111	-2.50
-3.300	506.600	-2.50	96+8.658			506.682	506.131	0.551	3.300	506.600	-2.50
-3.300	505.988	-2.50	97+0.000			506.071	505.456	0.615	3.300	505.988	-2.50
-3.300	505.460	-2.50	97+10.959	PCC		505.543	504.809	0.733	3.300	505.460	-2.50
-3.300	505.071	-2.50	98+0.000			505.154	504.259	0.894	3.300	505.071	-2.50
-3.300	504.361	-2.50	99+0.000			504.443	503.394	1.049	3.300	504.361	-2.50
-3.300	504.167	-2.50	99+6.752		PTV	504.250	503.185	1.065	3.300	504.167	-2.50
-3.300	503.855	-2.50	100+0.000			503.938	502.801	1.137	3.300	503.855	-2.50
-3.300	503.434	-2.50	101+0.000			503.516	502.590	0.926	3.300	503.434	-2.50
-3.300	503.380	-2.50	101+2.545	PCR		503.462	502.563	0.899	3.300	503.380	-2.50
-3.300	503.012	-2.50	102+0.000		PCV	503.094	502.357	0.737	3.300	503.012	-2.50
-3.300	502.714	-2.50	102+14.387			502.797	502.069	0.728	3.300	502.714	-2.50
-3.300	502.603	-2.50	103+0.000			502.685	501.928	0.757	3.300	502.603	-2.50
-3.300	502.226	-2.50	104+0.000			502.309	501.469	0.840	3.300	502.226	-2.50
-3.300	502.116	-2.50	104+6.229	PCR		502.198	501.419	0.779	3.300	502.116	-2.50
-3.300	501.883	-2.50	105+0.000			501.965	501.270	0.695	3.300	501.883	-2.50



-3.300	501.682	-2.50	105+12.678			501.764	501.130	0.634	3.300	501.682	-2.50
-3.300	501.572	-2.50	106+0.000			501.654	501.124	0.530	3.300	501.572	-2.50
-3.300	501.305	-2.50	106+19.128	PT		501.388	501.263	0.124	3.300	501.305	-2.50
-3.300	501.294	-2.50	107+0.000			501.376	501.272	0.105	3.300	501.294	-2.50
-3.300	501.049	-2.50	108+0.000			501.131	501.277	-0.146	3.300	501.049	-2.50
-3.300	500.836	-2.50	109+0.000			500.919	501.091	-0.172	3.300	500.836	-2.50
-3.300	500.657	-2.50	110+0.000		PTV	500.739	500.847	-0.107	3.300	500.657	-2.50
-3.300	500.510	-2.50	111+0.000			500.592	500.610	-0.017	3.300	500.510	-2.50
-3.300	500.375	-2.50	112+0.000		PCV	500.458	500.405	0.053	3.300	500.375	-2.50
-3.300	500.242	-2.50	113+0.000			500.325	500.211	0.114	3.300	500.242	-2.50
-3.300	500.223	-2.50	113+3.448	PC		500.306	500.178	0.127	3.300	500.223	-2.50
-3.300	500.163	-2.50	114+0.000			500.245	500.022	0.223	3.300	500.163	-2.50
-3.300	500.160	-2.50	114+1.382			500.242	500.011	0.232	3.300	500.160	-2.50
-3.300	500.158	-2.50	114+19.317	PCR		500.241	499.881	0.360	3.300	500.158	-2.50
-3.300	500.159	-2.50	115+0.000			500.242	499.884	0.358	3.300	500.159	-2.50
-3.300	500.233	-2.50	116+0.000			500.315	499.978	0.337	3.300	500.233	-2.50
-3.300	500.382	-2.50	117+0.000			500.465	500.441	0.024	3.300	500.382	-2.50
-3.300	500.509	-2.50	117+12.030			500.592	500.578	0.014	3.300	500.509	-2.50
-3.300	500.609	-2.50	118+0.000		PTV	500.691	500.625	0.067	3.300	500.609	-2.50
-3.300	500.909	-2.50	119+0.000			500.991	500.911	0.080	3.300	500.909	-2.50
-3.300	501.228	-2.50	120+0.000			501.310	501.225	0.086	3.300	501.228	-2.50
-3.300	501.303	-2.50	120+4.743			501.386	501.386	0.000	3.300	501.303	-2.50



# Relatório de Seções Transversais

Date: 03/02/2022 19:17:45

Nome do Corredor: CORREDOR LEOBERTO LEAL

Description:

Alinhamento Base: ALINHAMENTO LEOBERTO LEAL SC-408

Grupo de Sample Line: SEÇÕES - ALINHAMENTO LEOBERTO LEAL SC-408

Código: Top

Estacas: Início: 0+000,00, Final: 2+404,74

ALINHAMENTO LEOBERTO LEAL

Estaca: 0+000,00

**Cliente:**

**Criado por:**

Área de Corte: 3,33m<sup>2</sup>

Área de Aterro: 0,00m<sup>2</sup>

Volume Acumulado: 0,00m<sup>3</sup>

Cota Projeto: 546,000m

PLATAFORMA ACABADA LADO ESQUERDO	PTO	1	2	3	4	5	6	33
	DIST	3,300	3,409	3,618	3,698	3,907	4,016	4,133
	COTA	545,918m	545,918m	545,795m	545,795m	545,918m	545,918m	546,035m

PLATAFORMA ACABADA LADO DIREITO	PTO	1	2	3	4	5	33
	DIST	3,300m	3,409m	3,618m	3,698m	3,907m	4,016m
	COTA	545,918m	545,918m	545,795m	545,795m	545,918m	545,918m

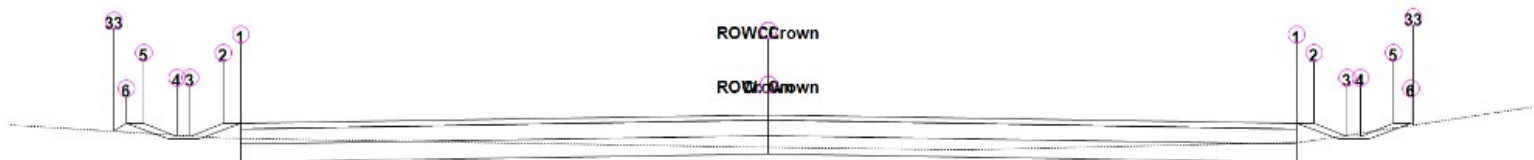

ALINHAMENTO LEOBERTO LEAL SC-408

Estaca: 0+020,00

Área de Corte: 0,88m<sup>2</sup>

Área de Aterro: 0,05m<sup>2</sup>

Volume Acumulado: 41,67m<sup>3</sup>

Cota Projeto: 545,065m

PLATAFORMA ACABADA LADO	PTO	1	2	3	4	5	6	33
	DIST	3,300	3,409	3,618	3,698	3,907	4,016	4,090
	COTA							

ESQUERDO	COTA	544,983m	544,983m	544,860m	544,860m	544,983m	544,983m	544,909m
----------	------	----------	----------	----------	----------	----------	----------	----------

PLATAFORMA ACABADA LADO DIREITO	PTO	1	2	3	4	5	6	33
	DIST	3,300m	3,409m	3,618m	3,698m	3,907m	4,016m	4,031m
	COTA	544,983m	544,983m	544,860m	544,860m	544,983m	544,983m	544,968m

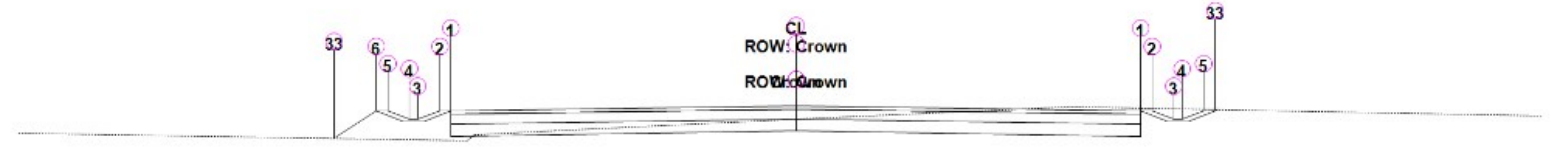

ALINHAMENTO LEOBERTO LEAL SC-408

Estaca: 0+036,84

Área de Corte: 1,49m<sup>2</sup>  
 Área de Aterro: 0,33m<sup>2</sup>  
 Volume Acumulado: 58,41m<sup>3</sup>  
 Cota Projeto: 544,233m

PLATAFORMA ACABADA LADO ESQUERDO	PTO	1	2	3	4	5	6	33
	DIST	3,300	3,409	3,618	3,698	3,907	4,016	4,424
	COTA	544,150m	544,150m	544,027m	544,027m	544,150m	544,150m	543,742m

PLATAFORMA ACABADA LADO DIREITO	PTO	1	2	3	4	5	33
	DIST	3,300m	3,409m	3,618m	3,698m	3,907m	4,016m
	COTA	544,150m	544,150m	544,027m	544,027m	544,150m	544,150m

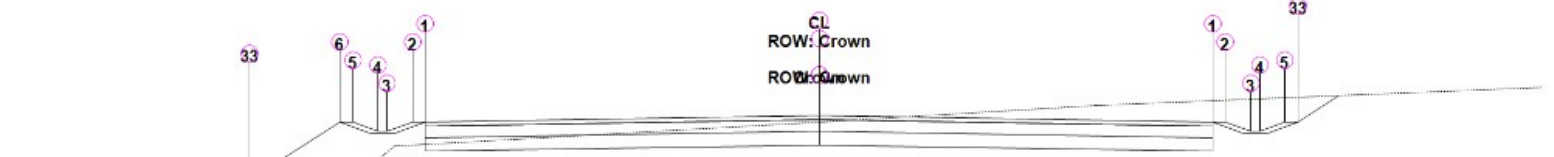

ALINHAMENTO LEOBERTO LEAL SC-408

Estaca: 0+040,00

Área de Corte: 2,60m<sup>2</sup>  
 Área de Aterro: 0,58m<sup>2</sup>  
 Volume Acumulado: 64,00m<sup>3</sup>  
 Cota Projeto: 544,069m

PLATAFORMA ACABADA LADO ESQUERDO	PTO	1	2	3	4	5	6	33
	DIST	3,300	3,409	3,618	3,698	3,907	4,016	4,771
	COTA	543,987m	543,987m	543,864m	543,864m	543,987m	543,987m	543,231m

PLATAFORMA ACABADA LADO DIREITO	PTO	1	2	3	4	5	33
	DIST	3,300m	3,409m	3,618m	3,698m	3,907m	4,016m
	COTA	543,987m	543,987m	543,864m	543,864m	543,987m	543,987m



ALINHAMENTO LEOBERTO LEAL SC-408

Estaca: 0+049,20

Área de Corte: 4,29m<sup>2</sup>  
 Área de Aterro: 0,25m<sup>2</sup>  
 Volume Acumulado: 93,98m<sup>3</sup>  
 Cota Projeto: 543,577m

PLATAFORMA ACABADA LADO ESQUERDO	PTO	1	2	3	4	5	6	33
	DIST	3,300	3,409	3,618	3,698	3,907	4,016	4,891
	COTA	543,494m	543,494m	543,371m	543,371m	543,494m	543,494m	542,620m

PLATAFORMA ACABADA LADO DIREITO	PTO	1	2	3	4	5	33
	DIST	3,300m	3,409m	3,618m	3,698m	3,907m	4,016m
	COTA	543,494m	543,494m	543,371m	543,371m	543,494m	543,494m

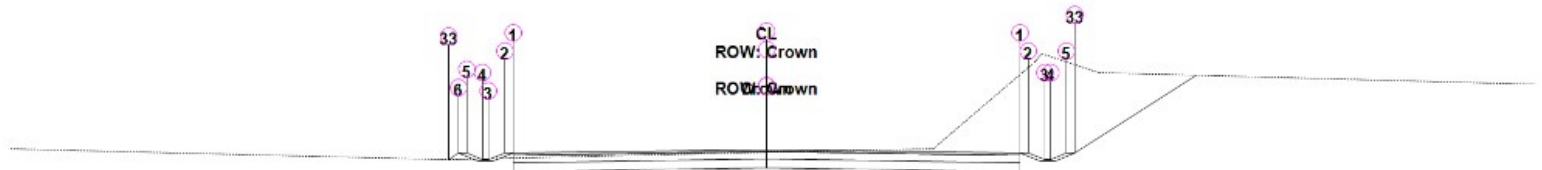

ALINHAMENTO LEOBERTO LEAL SC-408

Estaca: 0+060,00

Área de Corte: 5,93m<sup>2</sup>  
 Área de Aterro: 0,03m<sup>2</sup>  
 Volume Acumulado: 151,88m<sup>3</sup>  
 Cota Projeto: 542,972m

PLATAFORMA ACABADA LADO ESQUERDO	PTO	1	2	3	4	5	6	33
	DIST	3,300	3,409	3,618	3,698	3,907	4,016	4,142
	COTA	542,889m	542,889m	542,766m	542,766m	542,889m	542,889m	542,763m

PLATAFORMA ACABADA LADO DIREITO	PTO	1	2	3	4	5	33
	DIST	3,300m	3,409m	3,618m	3,698m	3,907m	4,016m
	COTA	542,889m	542,889m	542,766m	542,766m	542,889m	542,889m



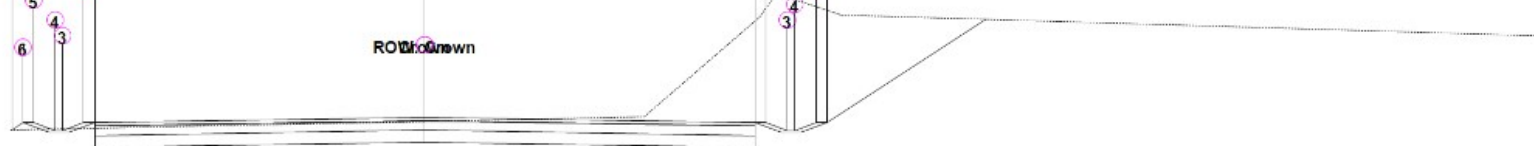

ALINHAMENTO LEOBERTO LEAL SC-408

Estaca: 0+061,55

Área de Corte: 5,90m<sup>2</sup>  
 Área de Aterro: 0,02m<sup>2</sup>  
 Volume Acumulado: 161,81m<sup>3</sup>  
 Cota Projeto: 542,882m

PLATAFORMA ACABADA LADO ESQUERDO	PTO	1	2	3	4	5	6	33
	DIST	3,300	3,409	3,618	3,698	3,907	4,016	4,127
	COTA	542,800m	542,800m	542,677m	542,677m	542,800m	542,800m	542,688m

PLATAFORMA ACABADA LADO DIREITO	PTO	1	2	3	4	5	33
	DIST	3,300m	3,409m	3,618m	3,698m	3,907m	4,016m
	COTA	542,800m	542,800m	542,677m	542,677m	542,800m	542,800m

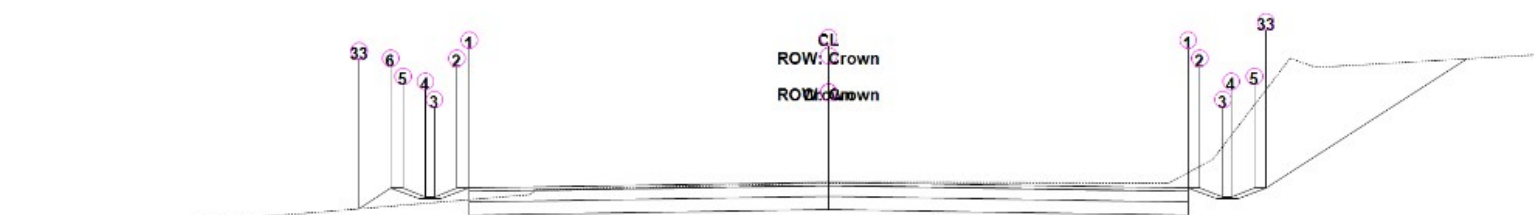

ALINHAMENTO LEOBERTO LEAL SC-408

Estaca: 0+076,43

Área de Corte: 4,62m<sup>2</sup>  
 Área de Aterro: 0,11m<sup>2</sup>  
 Volume Acumulado: 241,17m<sup>3</sup>  
 Cota Projeto: 541,994m

PLATAFORMA ACABADA LADO ESQUERDO	PTO	1	2	3	4	5	6	33
	DIST	3,300	3,409	3,618	3,698	3,907	4,016	4,305
	COTA	541,912m	541,912m	541,789m	541,789m	541,912m	541,912m	541,623m

PLATAFORMA ACABADA LADO DIREITO	PTO	1	2	3	4	5	33
	DIST	3,300m	3,409m	3,618m	3,698m	3,907m	4,016m
	COTA	541,912m	541,912m	541,789m	541,789m	541,912m	541,912m



ALINHAMENTO LEOBERTO LEAL SC-408

Estaca: 0+080,00

Área de Corte: 4,49m<sup>2</sup>  
 Área de Aterro: 0,43m<sup>2</sup>  
 Volume Acumulado: 256,81m<sup>3</sup>  
 Cota Projeto: 541,773m

PLATAFORMA ACABADA LADO ESQUERDO	PTO	1	2	3	4	5	6	33
	DIST	3,300	3,409	3,618	3,698	3,907	4,016	4,671
	COTA	541,690m	541,690m	541,567m	541,567m	541,690m	541,690m	541,035m

PLATAFORMA ACABADA LADO DIREITO	PTO	1	2	3	4	5	33
	DIST	3,300m	3,409m	3,618m	3,698m	3,907m	4,016m
	COTA	541,690m	541,690m	541,567m	541,567m	541,690m	541,690m

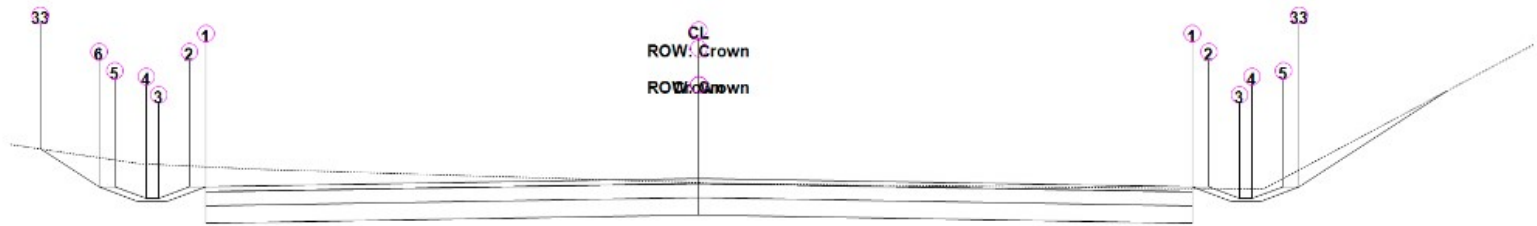

ALINHAMENTO LEOBERTO LEAL SC-408

Estaca: 0+091,32

Área de Corte: 3,11m<sup>2</sup>  
 Área de Aterro: 0,00m<sup>2</sup>  
 Volume Acumulado: 297,83m<sup>3</sup>  
 Cota Projeto: 541,050m

PLATAFORMA ACABADA LADO ESQUERDO	PTO	1	2	3	4	5	6	33
	DIST	3,300	3,409	3,618	3,698	3,907	4,016	4,408
	COTA	540,967m	540,967m	540,844m	540,844m	540,967m	540,967m	541,360m

PLATAFORMA ACABADA LADO DIREITO	PTO	1	2	3	4	5	33
	DIST	3,300m	3,409m	3,618m	3,698m	3,907m	4,016m
	COTA	540,967m	540,967m	540,844m	540,844m	540,967m	540,967m



ALINHAMENTO LEOBERTO LEAL SC-408

Estaca: 0+100,00

Área de Corte: 4,91m<sup>2</sup>  
 Área de Aterro: 0,00m<sup>2</sup>  
 Volume Acumulado: 331,65m<sup>3</sup>  
 Cota Projeto: 540,473m

PLATAFORMA ACABADA LADO ESQUERDO	PTO	1	2	3	4	5	6	33
	DIST	3,300	3,409	3,618	3,698	3,907	4,016	4,245
	COTA	540,390m	540,390m	540,267m	540,267m	540,390m	540,390m	540,620m

PLATAFORMA ACABADA LADO DIREITO	PTO	1	2	3	4	5	33
	DIST	3,300m	3,409m	3,618m	3,698m	3,907m	4,016m
	COTA	540,390m	540,390m	540,267m	540,267m	540,390m	540,390m

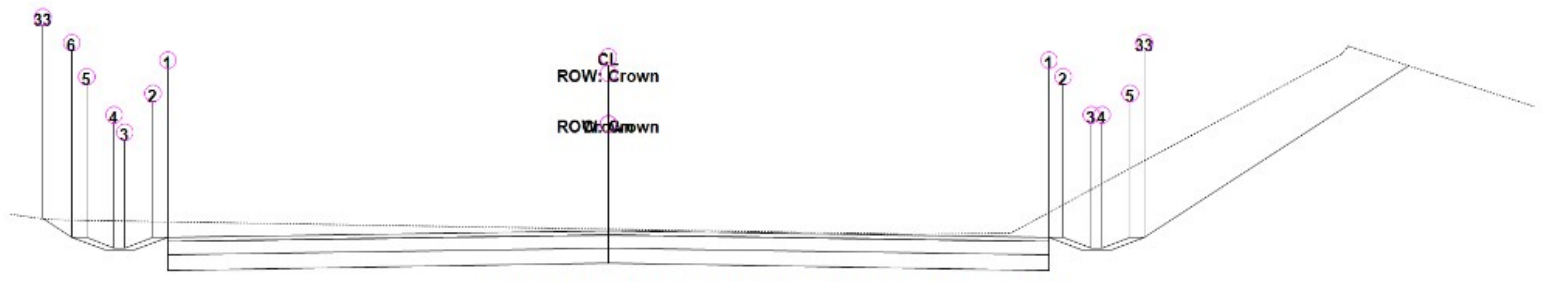

ALINHAMENTO LEOBERTO LEAL SC-408

Estaca: 0+100,18

Área de Corte: 4,99m<sup>2</sup>  
 Área de Aterro: 0,00m<sup>2</sup>  
 Volume Acumulado: 332,51m<sup>3</sup>  
 Cota Projeto: 540,461m

PLATAFORMA ACABADA LADO ESQUERDO	PTO	1	2	3	4	5	6	33
	DIST	3,300	3,409	3,618	3,698	3,907	4,016	4,233
	COTA	540,379m	540,379m	540,256m	540,256m	540,379m	540,379m	540,596m

PLATAFORMA ACABADA LADO DIREITO	PTO	1	2	3	4	5	33
	DIST	3,300m	3,409m	3,618m	3,698m	3,907m	4,016m
	COTA	540,379m	540,379m	540,256m	540,256m	540,379m	540,379m



ALINHAMENTO LEOBERTO LEAL SC-408

Estaca: 0+109,03

Área de Corte: 3,84m<sup>2</sup>  
 Área de Aterro: 0,01m<sup>2</sup>  
 Volume Acumulado: 369,89m<sup>3</sup>  
 Cota Projeto: 539,853m

PLATAFORMA ACABADA LADO ESQUERDO	PTO	1	2	3	4	5	6	33
	DIST	3,300	3,409	3,618	3,698	3,907	4,016	4,156
	COTA	539,770m	539,770m	539,647m	539,647m	539,770m	539,770m	539,630m

PLATAFORMA ACABADA LADO DIREITO	PTO	1	2	3	4	5	33
	DIST	3,300m	3,409m	3,618m	3,698m	3,907m	4,016m
	COTA	539,770m	539,770m	539,647m	539,647m	539,770m	539,770m

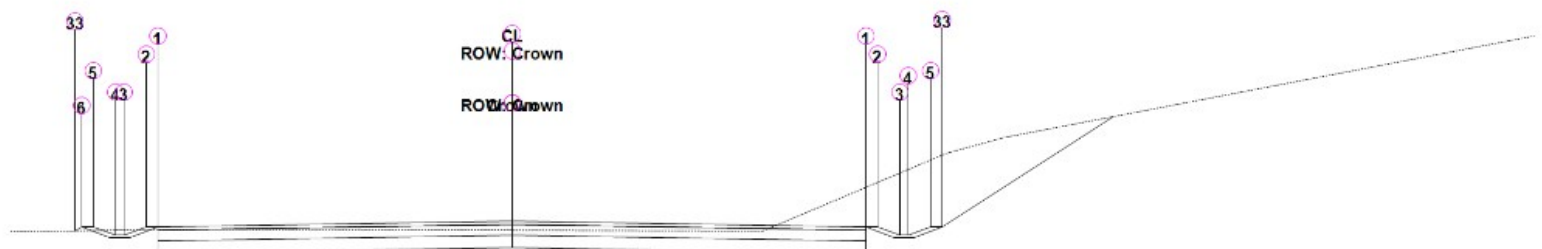

ALINHAMENTO LEOBERTO LEAL SC-408

Estaca: 0+120,00

Área de Corte: 3,74m<sup>2</sup>  
 Área de Aterro: 0,01m<sup>2</sup>  
 Volume Acumulado: 410,50m<sup>3</sup>  
 Cota Projeto: 539,072m

PLATAFORMA ACABADA LADO ESQUERDO	PTO	1	2	3	4	5	6	33
	DIST	3,300	3,409	3,618	3,698	3,907	4,016	4,076
	COTA	538,989m	538,989m	538,866m	538,866m	538,989m	538,989m	538,929m

PLATAFORMA ACABADA LADO DIREITO	PTO	1	2	3	4	5	33
	DIST	3,300m	3,409m	3,618m	3,698m	3,907m	4,016m
	COTA	538,989m	538,989m	538,866m	538,866m	538,989m	538,989m

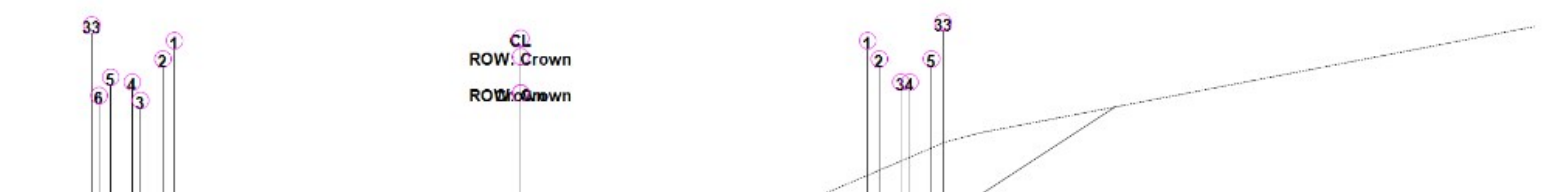

ALINHAMENTO LEOBERTO LEAL SC-408

Estaca: 0+120,93

Área de Corte: 3,84m<sup>2</sup>  
 Área de Aterro: 0,01m<sup>2</sup>  
 Volume Acumulado: 414,03m<sup>3</sup>  
 Cota Projeto: 539,004m

PLATAFORMA ACABADA LADO ESQUERDO	PTO	1	2	3	4	5	6	33
	DIST	3,300	3,409	3,618	3,698	3,907	4,016	4,082
	COTA	538,921m	538,921m	538,798m	538,798m	538,921m	538,921m	538,855m

PLATAFORMA ACABADA LADO DIREITO	PTO	1	2	3	4	5	33
	DIST	3,300m	3,409m	3,618m	3,698m	3,907m	4,016m
	COTA	538,921m	538,921m	538,798m	538,798m	538,921m	538,921m

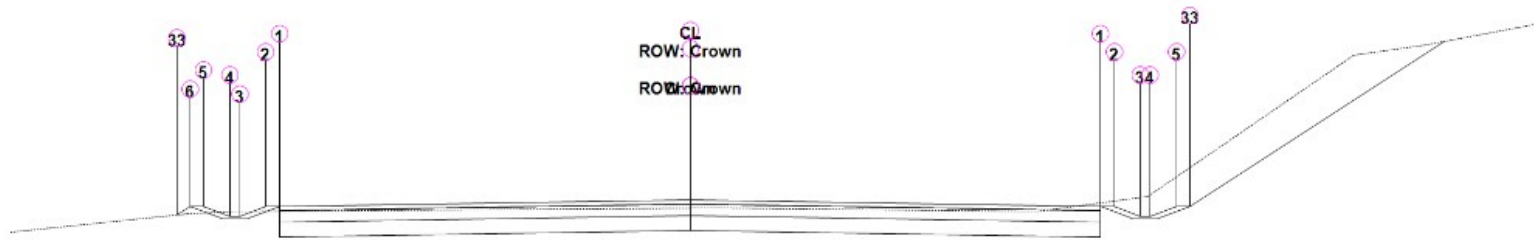

ALINHAMENTO LEOBERTO LEAL SC-408

Estaca: 0+132,84

Área de Corte: 3,09m<sup>2</sup>  
 Área de Aterro: 0,01m<sup>2</sup>  
 Volume Acumulado: 453,92m<sup>3</sup>  
 Cota Projeto: 538,119m

PLATAFORMA ACABADA LADO ESQUERDO	PTO	1	2	3	4	5	6	33
	DIST	3,300	3,409	3,618	3,698	3,907	4,016	4,119
	COTA	538,037m	538,037m	537,914m	537,914m	538,037m	538,037m	537,933m

PLATAFORMA ACABADA LADO DIREITO	PTO	1	2	3	4	5	33
	DIST	3,300m	3,409m	3,618m	3,698m	3,907m	4,016m
	COTA	538,037m	538,037m	537,914m	537,914m	538,037m	538,037m

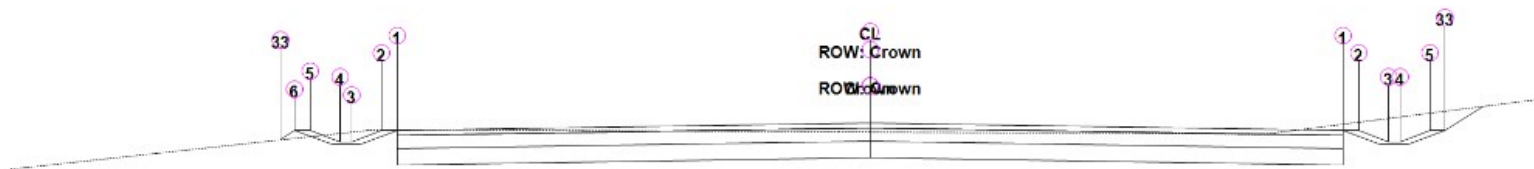

ALINHAMENTO LEOBERTO LEAL SC-408

Estaca: 0+140,00



Área de Corte: 2,42m<sup>2</sup>  
 Área de Aterro: 0,01m<sup>2</sup>  
 Volume Acumulado: 473,29m<sup>3</sup>  
 Cota Projeto: 537,569m

PLATAFORMA ACABADA LADO ESQUERDO	PTO	1	2	3	4	5	6	33
	DIST	3,300	3,409	3,618	3,698	3,907	4,016	4,117
	COTA	537,487m	537,487m	537,364m	537,364m	537,487m	537,487m	537,386m

PLATAFORMA ACABADA LADO DIREITO	PTO	1	2	3	4	5	33
	DIST	3,300m	3,409m	3,618m	3,698m	3,907m	4,016m
	COTA	537,487m	537,487m	537,364m	537,364m	537,487m	537,487m

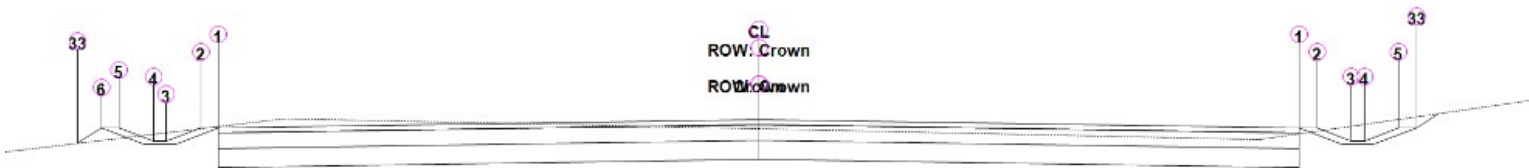

ALINHAMENTO LEOBERTO LEAL SC-408

Estaca: 0+146,64

Área de Corte: 2,31m<sup>2</sup>  
 Área de Aterro: 0,02m<sup>2</sup>  
 Volume Acumulado: 488,92m<sup>3</sup>  
 Cota Projeto: 537,048m

PLATAFORMA ACABADA LADO ESQUERDO	PTO	1	2	3	4	5	6	33
	DIST	3,300	3,409	3,618	3,698	3,907	4,016	4,159
	COTA	536,965m	536,965m	536,842m	536,842m	536,965m	536,965m	536,822m

PLATAFORMA ACABADA LADO DIREITO	PTO	1	2	3	4	5	33
	DIST	3,300m	3,409m	3,618m	3,698m	3,907m	4,016m
	COTA	536,965m	536,965m	536,842m	536,842m	536,965m	536,965m

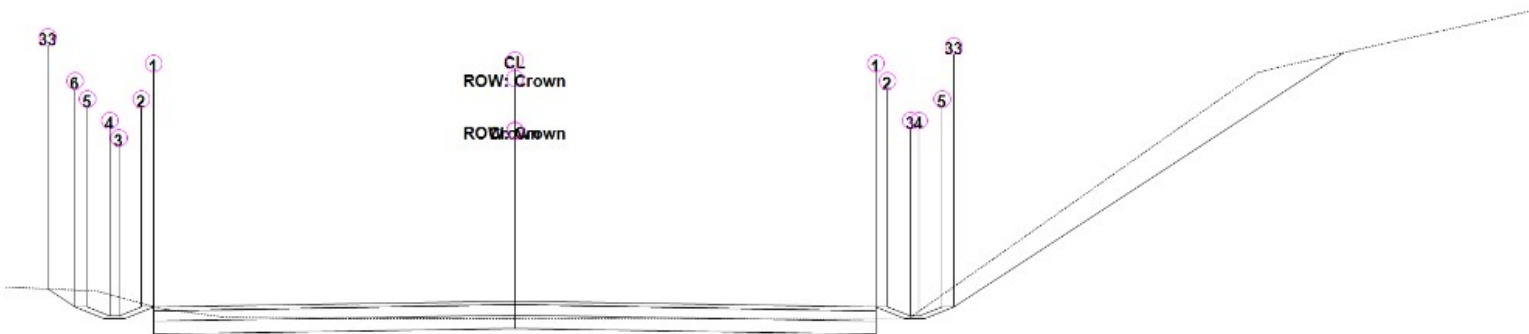

ALINHAMENTO LEOBERTO LEAL SC-408

Estaca: 0+160,00

Área de Corte: 2,70m<sup>2</sup>

Área de Corte: 2,79m<sup>2</sup>  
 Área de Aterro: 0,03m<sup>2</sup>  
 Volume Acumulado: 522,15m<sup>3</sup>  
 Cota Projeto: 535,966m

PLATAFORMA ACABADA LADO ESQUERDO	PTO	1	2	3	4	5	6	33
	DIST	3,300	3,409	3,618	3,698	3,907	4,016	4,270
	COTA	535,883m	535,883m	535,760m	535,760m	535,883m	535,883m	536,138m

PLATAFORMA ACABADA LADO DIREITO	PTO	1	2	3	4	5	33
	DIST	3,300m	3,409m	3,618m	3,698m	3,907m	4,016m
	COTA	535,883m	535,883m	535,760m	535,760m	535,883m	535,883m

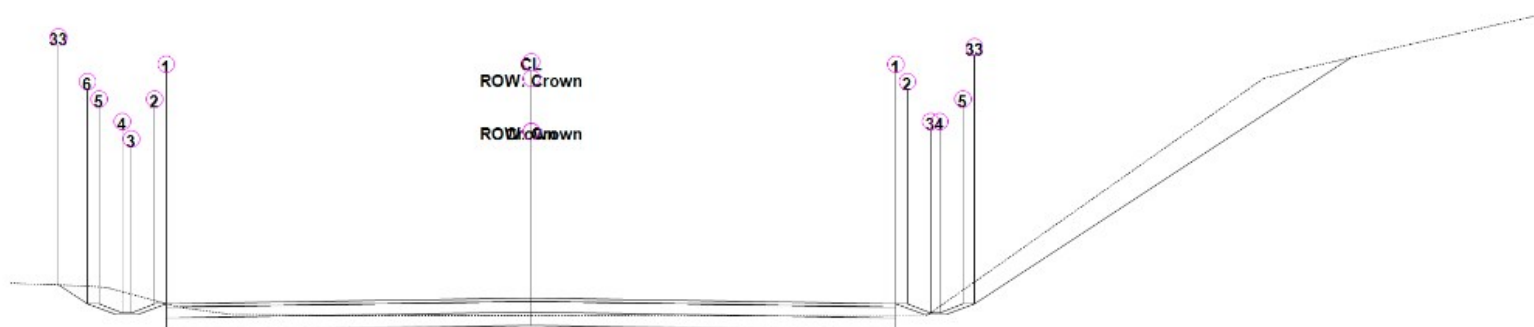

ALINHAMENTO LEOBERTO LEAL SC-408

Estaca: 0+160,45

Área de Corte: 2,75m<sup>2</sup>  
 Área de Aterro: 0,03m<sup>2</sup>  
 Volume Acumulado: 523,40m<sup>3</sup>  
 Cota Projeto: 535,928m

PLATAFORMA ACABADA LADO ESQUERDO	PTO	1	2	3	4	5	6	33
	DIST	3,300	3,409	3,618	3,698	3,907	4,016	4,275
	COTA	535,846m	535,846m	535,723m	535,723m	535,846m	535,846m	536,105m

PLATAFORMA ACABADA LADO DIREITO	PTO	1	2	3	4	5	33
	DIST	3,300m	3,409m	3,618m	3,698m	3,907m	4,016m
	COTA	535,846m	535,846m	535,723m	535,723m	535,846m	535,846m

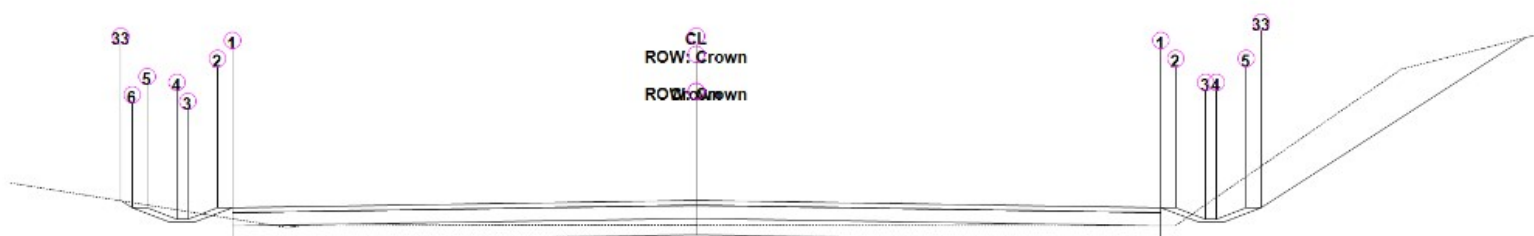

ALINHAMENTO LEOBERTO LEAL SC-408

Área de Corte: 1,91m<sup>2</sup>  
 Área de Aterro: 0,03m<sup>2</sup>  
 Volume Acumulado: 532,55m<sup>3</sup>  
 Cota Projeto: 535,598m

PLATAFORMA ACABADA LADO ESQUERDO	PTO	1	2	3	4	5	6	33
	DIST	3,300	3,409	3,618	3,698	3,907	4,016	4,097
	COTA	535,515m	535,515m	535,392m	535,392m	535,515m	535,515m	535,596m

PLATAFORMA ACABADA LADO DIREITO	PTO	1	2	3	4	5	33
	DIST	3,300m	3,409m	3,618m	3,698m	3,907m	4,016m
	COTA	535,515m	535,515m	535,392m	535,392m	535,515m	535,515m

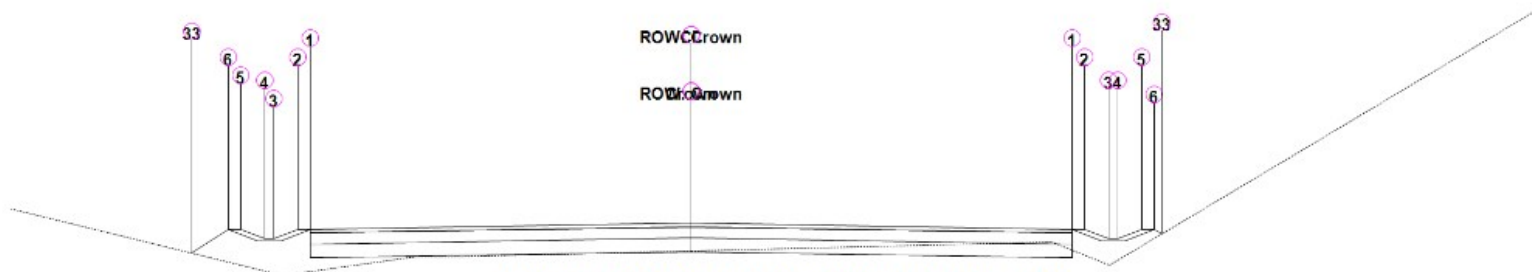

ALINHAMENTO LEOBERTO LEAL SC-408

Estaca: 0+180,00

Área de Corte: 0,37m<sup>2</sup>  
 Área de Aterro: 0,66m<sup>2</sup>  
 Volume Acumulado: 544,94m<sup>3</sup>  
 Cota Projeto: 534,261m

PLATAFORMA ACABADA LADO ESQUERDO	PTO	1	2	3	4	5	6	33
	DIST	3,300	3,409	3,618	3,698	3,907	4,016	4,332
	COTA	534,178m	534,178m	534,055m	534,055m	534,178m	534,178m	533,862m

PLATAFORMA ACABADA LADO DIREITO	PTO	1	2	3	4	5	6	33
	DIST	3,300m	3,409m	3,618m	3,698m	3,907m	4,016m	4,076m
	COTA	534,178m	534,178m	534,055m	534,055m	534,178m	534,178m	534,118m

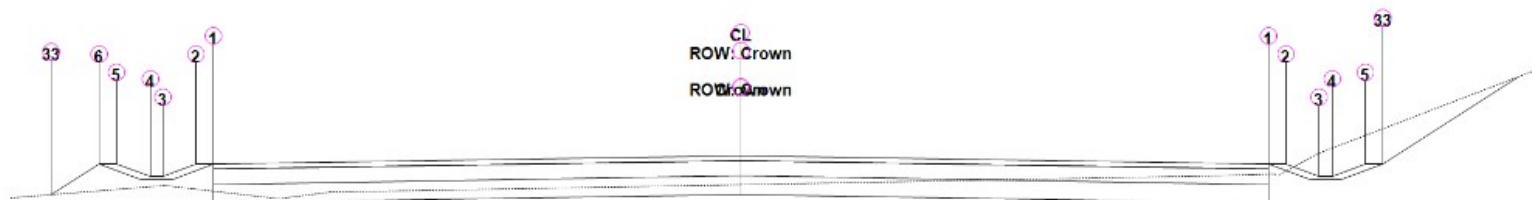

ALINHAMENTO LEOBERTO LEAL SC-408

Estaca: 0+189,29

Área de Corte: 1,21m<sup>2</sup>  
 Área de Aterro: 0,15m<sup>2</sup>  
 Volume Acumulado: 548,55m<sup>3</sup>  
 Cota Projeto: 533,434m

PLATAFORMA ACABADA LADO ESQUERDO	PTO	1	2	3	4	5	6	33
	DIST	3,300	3,409	3,618	3,698	3,907	4,016	4,317
	COTA	533,352m	533,352m	533,229m	533,229m	533,352m	533,352m	533,050m

PLATAFORMA ACABADA LADO DIREITO	PTO	1	2	3	4	5	33
	DIST	3,300m	3,409m	3,618m	3,698m	3,907m	4,016m
	COTA	533,352m	533,352m	533,229m	533,229m	533,352m	533,352m

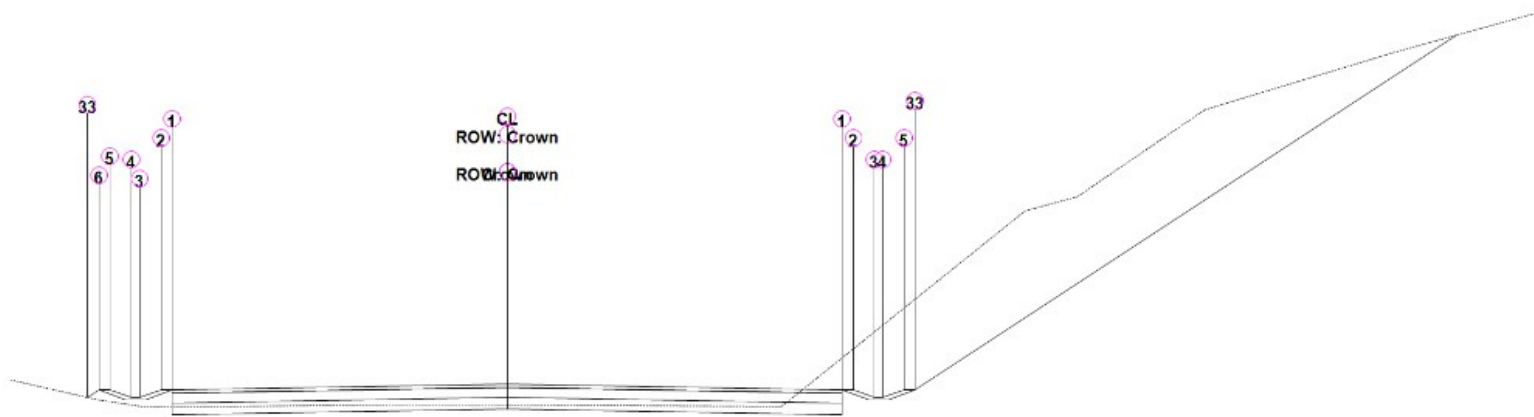

ALINHAMENTO LEOBERTO LEAL SC-408

Estaca: 0+200,00

Área de Corte: 7,31m<sup>2</sup>  
 Área de Aterro: 0,11m<sup>2</sup>  
 Volume Acumulado: 593,23m<sup>3</sup>  
 Cota Projeto: 532,455m

PLATAFORMA ACABADA LADO ESQUERDO	PTO	1	2	3	4	5	6	33
	DIST	3,300	3,409	3,618	3,698	3,907	4,016	4,134
	COTA	532,372m	532,372m	532,249m	532,249m	532,372m	532,372m	532,254m

PLATAFORMA ACABADA LADO DIREITO	PTO	1	2	3	4	5	33
	DIST	3,300m	3,409m	3,618m	3,698m	3,907m	4,016m
	COTA	532,372m	532,372m	532,249m	532,249m	532,372m	532,372m



ALINHAMENTO LEOBERTO LEAL SC-408

Estaca: 0+214,16

Área de Corte: 11,82m<sup>2</sup>  
 Área de Aterro: 0,24m<sup>2</sup>  
 Volume Acumulado: 727,87m<sup>3</sup>  
 Cota Projeto: 531,115m

PLATAFORMA ACABADA LADO ESQUERDO	PTO	1	2	3	4	5	6	33
	DIST	3,300	3,409	3,618	3,698	3,907	4,016	4,198
	COTA	531,032m	531,032m	530,909m	530,909m	531,032m	531,032m	530,850m

PLATAFORMA ACABADA LADO DIREITO	PTO	1	2	3	4	5	33
	DIST	3,300m	3,409m	3,618m	3,698m	3,907m	4,016m
	COTA	531,032m	531,032m	530,909m	530,909m	531,032m	531,032m

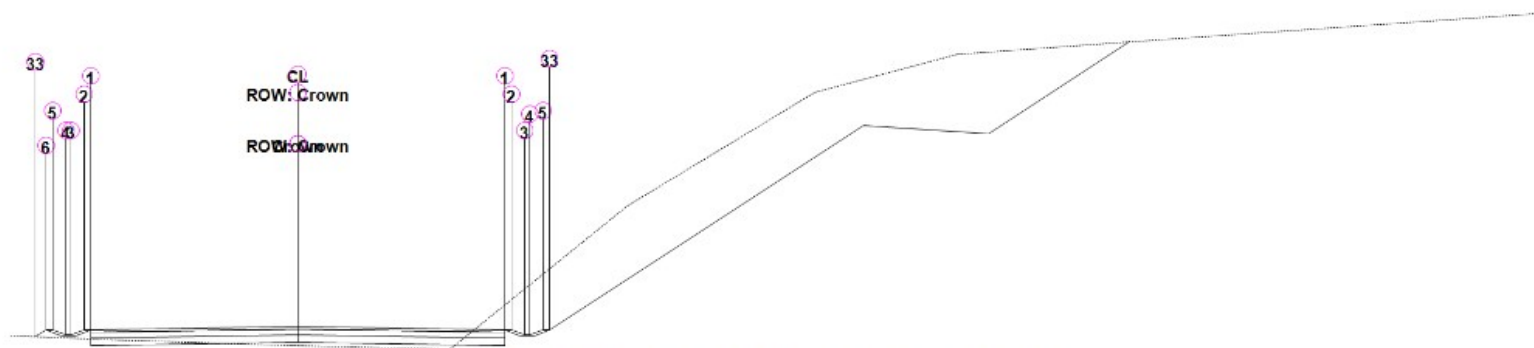

ALINHAMENTO LEOBERTO LEAL SC-408

Estaca: 0+220,00

Área de Corte: 14,96m<sup>2</sup>  
 Área de Aterro: 0,38m<sup>2</sup>  
 Volume Acumulado: 795,42m<sup>3</sup>  
 Cota Projeto: 530,548m

PLATAFORMA ACABADA LADO ESQUERDO	PTO	1	2	3	4	5	6	33
	DIST	3,300	3,409	3,618	3,698	3,907	4,016	4,179
	COTA	530,465m	530,465m	530,342m	530,342m	530,465m	530,465m	530,302m

PLATAFORMA ACABADA LADO DIREITO	PTO	1	2	3	4	5	33
	DIST	3,300m	3,409m	3,618m	3,698m	3,907m	4,016m
	COTA	530,465m	530,465m	530,342m	530,342m	530,465m	530,465m

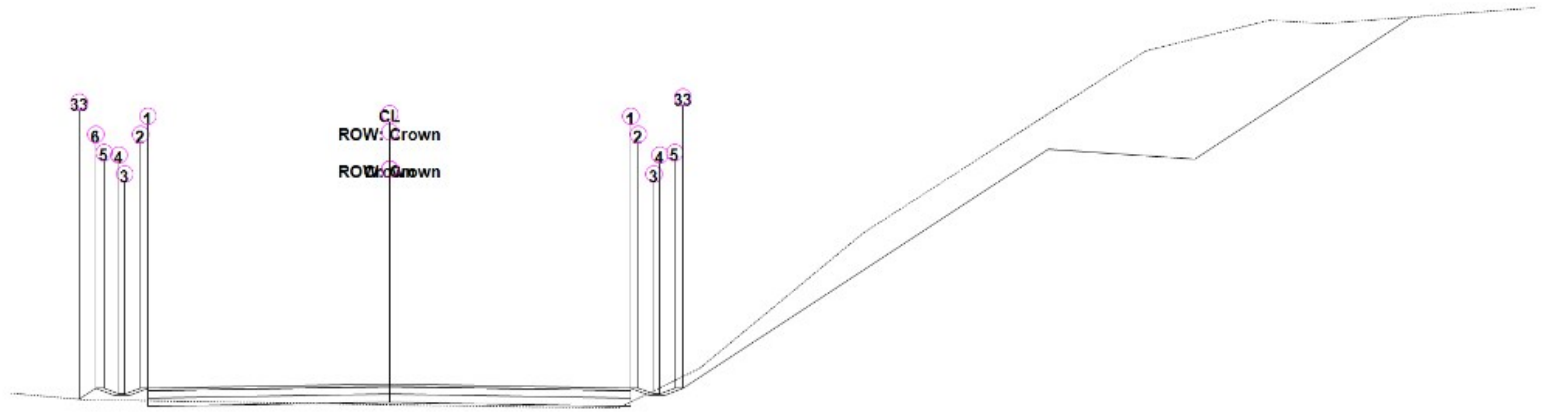

ALINHAMENTO LEOBERTO LEAL SC-408

Estaca: 0+231,97

Área de Corte: 10,80m<sup>2</sup>  
 Área de Aterro: 0,34m<sup>2</sup>  
 Volume Acumulado: 932,83m<sup>3</sup>  
 Cota Projeto: 529,383m

PLATAFORMA ACABADA LADO ESQUERDO	PTO	1	2	3	4	5	6	33
	DIST	3,300	3,409	3,618	3,698	3,907	4,016	4,241
	COTA	529,301m	529,301m	529,178m	529,178m	529,301m	529,301m	529,075m

PLATAFORMA ACABADA LADO DIREITO	PTO	1	2	3	4	5	33
	DIST	3,300m	3,409m	3,618m	3,698m	3,907m	4,016m
	COTA	529,301m	529,301m	529,178m	529,178m	529,301m	529,301m

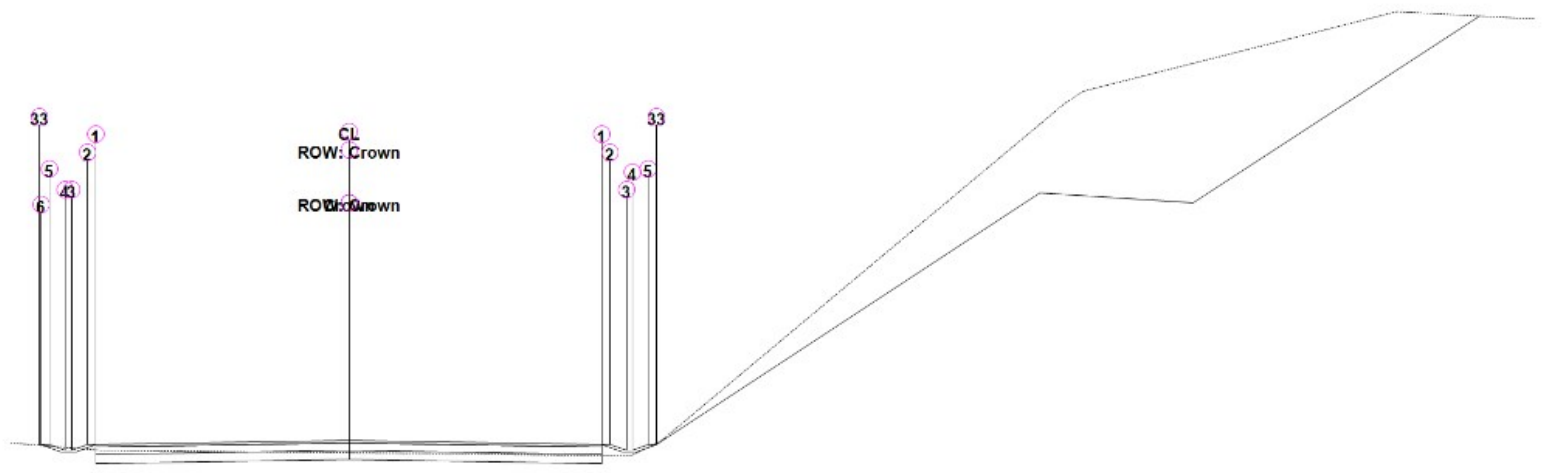

ALINHAMENTO LEOBERTO LEAL SC-408

Estaca: 0+240,00

Área de Corte: 14,98m<sup>2</sup>  
 Área de Aterro: 0,06m<sup>2</sup>  
 Volume Acumulado: 1.025,41m<sup>3</sup>  
 Cota Projeto: 528,601m

PLATAFORMA	PTO	1	2	3	4	5	6	33
------------	-----	---	---	---	---	---	---	----

PLATAFORMA ACABADA LADO ESQUERDO	PTO	1	2	3	4	5	6	33
	DIST	3,300	3,409	3,618	3,698	3,907	4,016	4,038
	COTA	528,519m	528,519m	528,396m	528,396m	528,519m	528,519m	528,496m

PLATAFORMA ACABADA LADO DIREITO	PTO	1	2	3	4	5	33
	DIST	3,300m	3,409m	3,618m	3,698m	3,907m	4,016m
	COTA	528,519m	528,519m	528,396m	528,396m	528,519m	528,519m

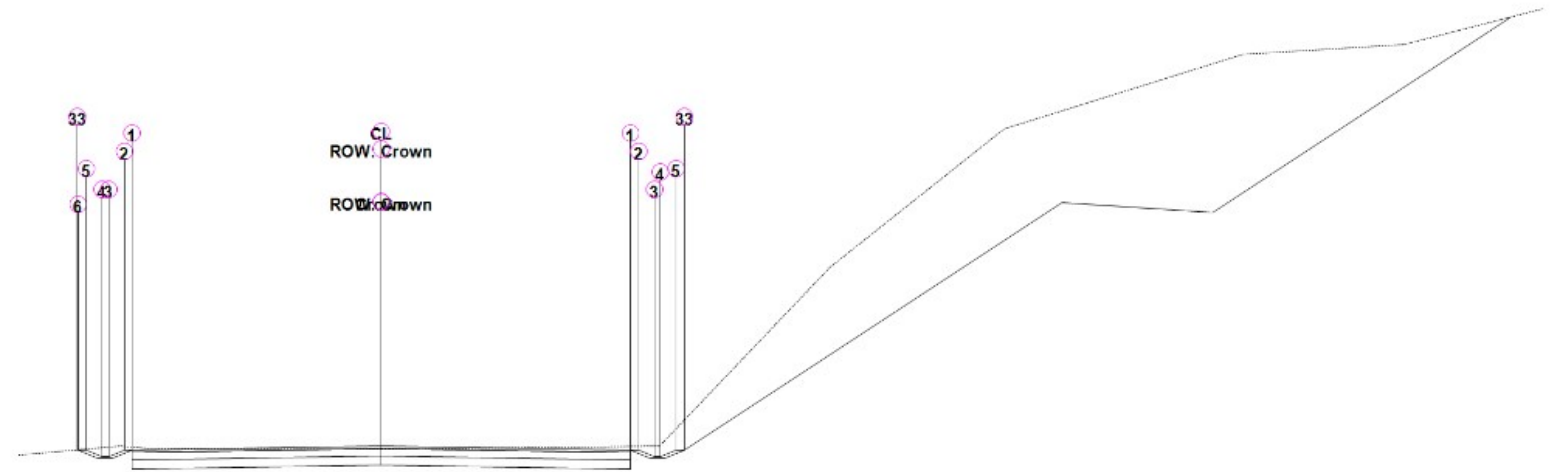

ALINHAMENTO LEOBERTO LEAL SC-408

Estaca: 0+249,77

Área de Corte: 21,96m<sup>2</sup>  
 Área de Aterro: 0,00m<sup>2</sup>  
 Volume Acumulado: 1.190,85m<sup>3</sup>  
 Cota Projeto: 527,650m

PLATAFORMA ACABADA LADO ESQUERDO	PTO	1	2	3	4	5	6	33
	DIST	3,300	3,409	3,618	3,698	3,907	4,016	4,025
	COTA	527,568m	527,568m	527,445m	527,445m	527,568m	527,568m	527,577m

PLATAFORMA ACABADA LADO DIREITO	PTO	1	2	3	4	5	33
	DIST	3,300m	3,409m	3,618m	3,698m	3,907m	4,016m
	COTA	527,568m	527,568m	527,445m	527,445m	527,568m	527,568m

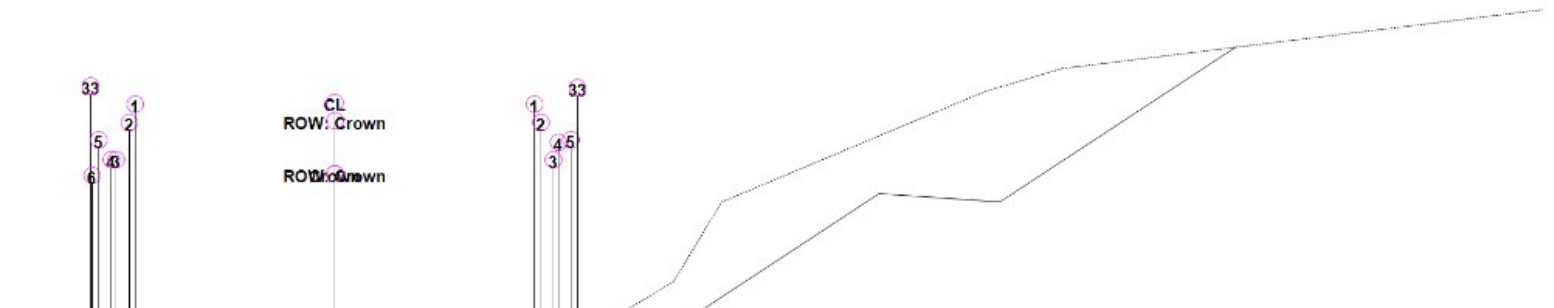

ALINHAMENTO LEOBERTO LEAL SC-408

Estaca: 0+260,00

Área de Corte: 23,99m<sup>2</sup>  
 Área de Aterro: 0,00m<sup>2</sup>  
 Volume Acumulado: 1.446,60m<sup>3</sup>  
 Cota Projeto: 526,655m

PLATAFORMA ACABADA LADO ESQUERDO	PTO	1	2	3	4	5	6	33
	DIST	3,300	3,409	3,618	3,698	3,907	4,016	4,048
	COTA	526,572m	526,572m	526,449m	526,449m	526,572m	526,572m	526,604m

PLATAFORMA ACABADA LADO DIREITO	PTO	1	2	3	4	5	33
	DIST	3,300m	3,409m	3,618m	3,698m	3,907m	4,016m
	COTA	526,572m	526,572m	526,449m	526,449m	526,572m	526,572m

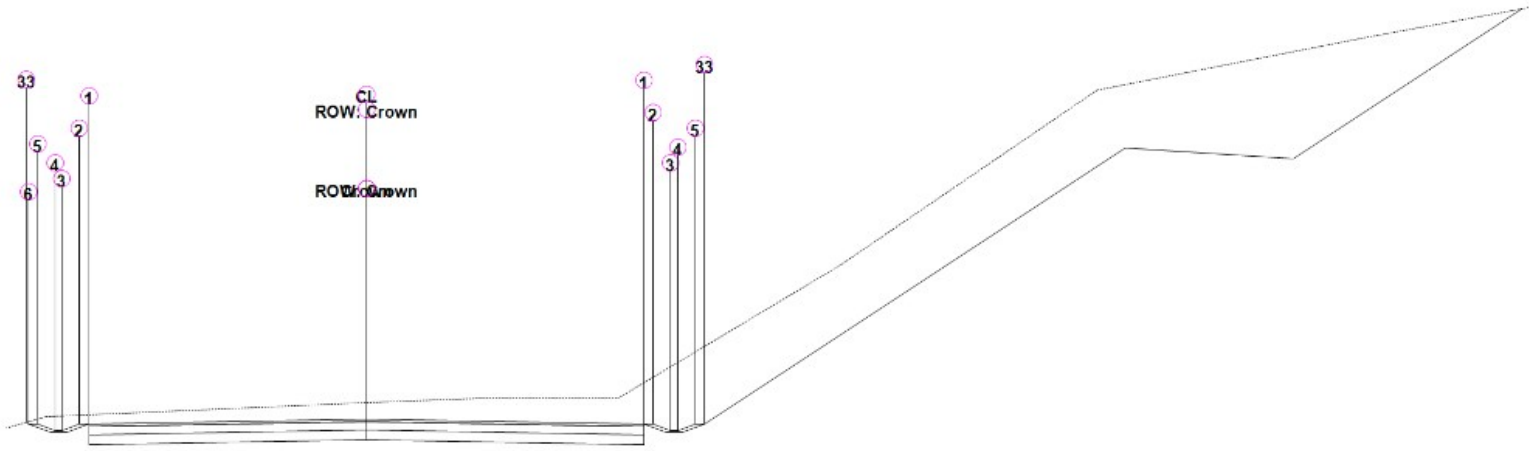

ALINHAMENTO LEOBERTO LEAL SC-408

Estaca: 0+273,72

Área de Corte: 18,03m<sup>2</sup>  
 Área de Aterro: 0,00m<sup>2</sup>  
 Volume Acumulado: 1.760,26m<sup>3</sup>  
 Cota Projeto: 525,319m

PLATAFORMA ACABADA LADO ESQUERDO	PTO	1	2	3	4	5	6	33
	DIST	3,300	3,409	3,618	3,698	3,907	4,016	4,042
	COTA	525,236m	525,236m	525,113m	525,113m	525,236m	525,236m	525,263m

PLATAFORMA ACABADA LADO DIREITO	PTO	1	2	3	4	5	33
	DIST	3,300m	3,409m	3,618m	3,698m	3,907m	4,016m
	COTA	525,236m	525,236m	525,113m	525,113m	525,236m	525,236m





LADO ESQUERDO	COTA	522,905m	522,905m	522,782m	522,782m	522,905m	522,905m	523,076m
---------------	------	----------	----------	----------	----------	----------	----------	----------

PLATAFORMA ACABADA LADO DIREITO	PTO	1	2	3	4	5	33
	DIST	3,300m	3,409m	3,618m	3,698m	3,907m	4,016m
	COTA	522,905m	522,905m	522,782m	522,782m	522,905m	522,905m

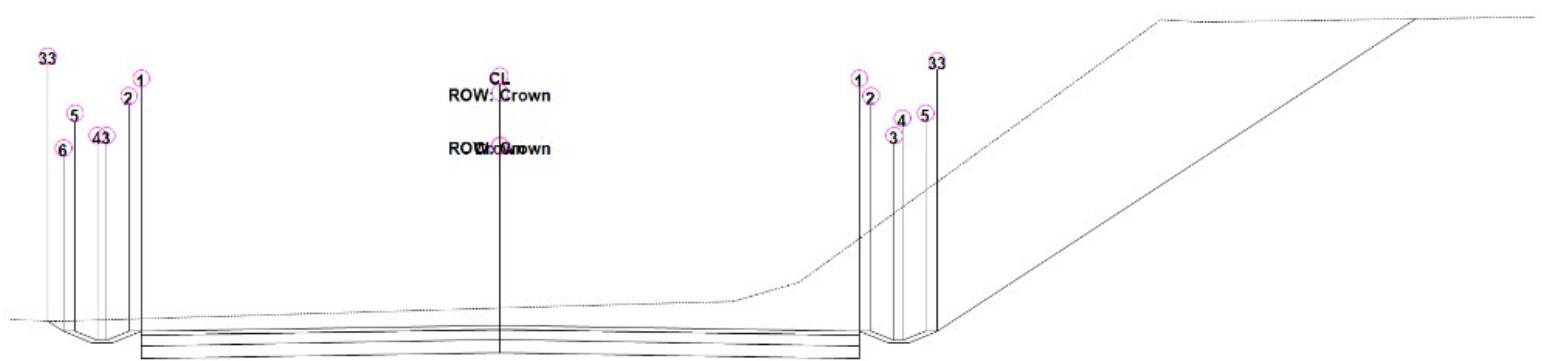

ALINHAMENTO LEOBERTO LEAL SC-408

Estaca: 0+300,00

Área de Corte: 13,51m<sup>2</sup>  
 Área de Aterro: 0,00m<sup>2</sup>  
 Volume Acumulado: 2.142,39m<sup>3</sup>  
 Cota Projeto: 522,761m

PLATAFORMA ACABADA LADO ESQUERDO	PTO	1	2	3	4	5	6	33
	DIST	3,300	3,409	3,618	3,698	3,907	4,016	4,160
	COTA	522,679m	522,679m	522,556m	522,556m	522,679m	522,679m	522,824m

PLATAFORMA ACABADA LADO DIREITO	PTO	1	2	3	4	5	33
	DIST	3,300m	3,409m	3,618m	3,698m	3,907m	4,016m
	COTA	522,679m	522,679m	522,556m	522,556m	522,679m	522,679m

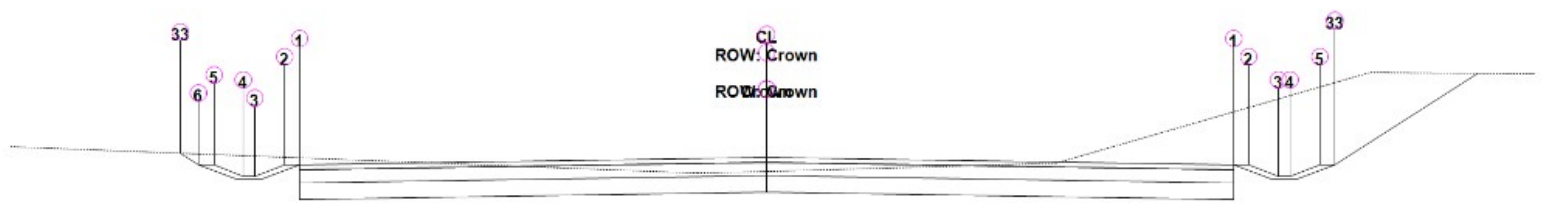

ALINHAMENTO LEOBERTO LEAL SC-408

Estaca: 0+320,00

Área de Corte: 3,77m<sup>2</sup>  
 Área de Aterro: 0,00m<sup>2</sup>  
 Volume Acumulado: 2.315,27m<sup>3</sup>  
 Cota Projeto: 521,002m

PLATAFORMA ACABADA	PTO	1	2	3	4	5	6	33
--------------------	-----	---	---	---	---	---	---	----

ACABADA	DIST	3,300	3,409	3,618	3,698	3,907	4,016	4,144
LADO ESQUERDO	COTA	520,920m	520,920m	520,797m	520,797m	520,920m	520,920m	521,048m

PLATAFORMA ACABADA LADO DIREITO	PTO	1	2	3	4	5	33
	DIST	3,300m	3,409m	3,618m	3,698m	3,907m	4,016m
	COTA	520,920m	520,920m	520,797m	520,797m	520,920m	520,920m

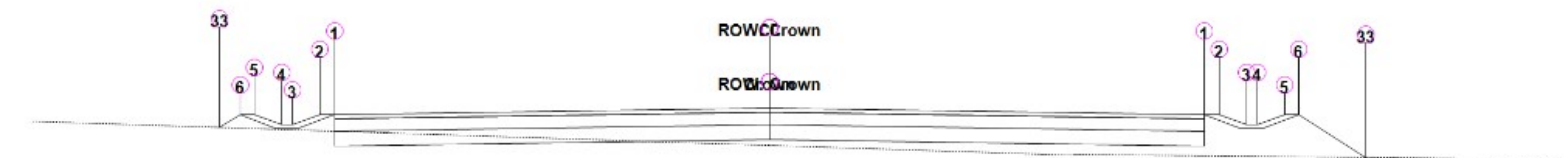

ALINHAMENTO LEOBERTO LEAL SC-408

Estaca: 0+334,73

Área de Corte: 0,22m<sup>2</sup>  
 Área de Aterro: 0,86m<sup>2</sup>  
 Volume Acumulado: 2.338,32m<sup>3</sup>  
 Cota Projeto: 519,988m

PLATAFORMA ACABADA LADO ESQUERDO	PTO	1	2	3	4	5	6	33
	DIST	3,300	3,409	3,618	3,698	3,907	4,016	4,167
	COTA	519,906m	519,906m	519,783m	519,783m	519,906m	519,906m	519,755m

PLATAFORMA ACABADA LADO DIREITO	PTO	1	2	3	4	5	6	33
	DIST	3,300m	3,409m	3,618m	3,698m	3,907m	4,016m	4,526m
	COTA	519,906m	519,906m	519,783m	519,783m	519,906m	519,906m	519,396m

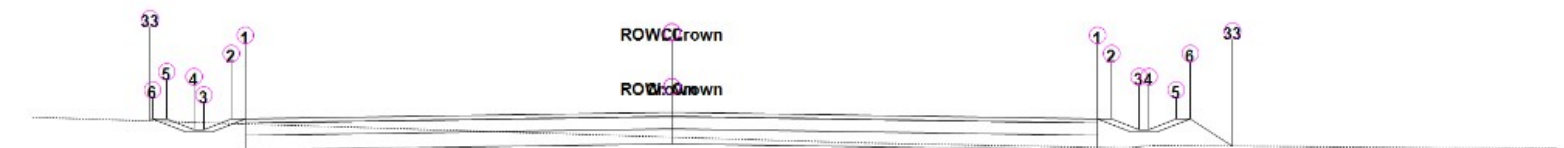

ALINHAMENTO LEOBERTO LEAL SC-408

Estaca: 0+340,00

Área de Corte: 0,86m<sup>2</sup>  
 Área de Aterro: 0,22m<sup>2</sup>  
 Volume Acumulado: 2.338,51m<sup>3</sup>  
 Cota Projeto: 519,683m

PLATAFORMA ACABADA LADO ESQUERDO	PTO	1	2	3	4	5	6	33
	DIST	3,300	3,409	3,618	3,698	3,907	4,016	4,035
	COTA	519,601m	519,601m	519,478m	519,478m	519,601m	519,601m	519,581m

PLATAFORMA ACABADA LADO DIREITO	PTO	1	2	3	4	5	6	33
	DIST	3,300m	3,409m	3,618m	3,698m	3,907m	4,016m	4,341m
	COTA	519,601m	519,601m	519,478m	519,478m	519,601m	519,601m	519,275m

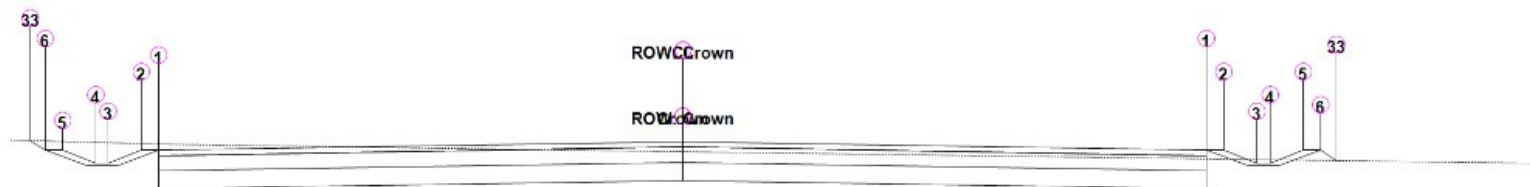

ALINHAMENTO LEOBERTO LEAL SC-408

Estaca: 0+360,00

Área de Corte: 2,32m<sup>2</sup>  
 Área de Aterro: 0,02m<sup>2</sup>  
 Volume Acumulado: 2.368,24m<sup>3</sup>  
 Cota Projeto: 518,806m

PLATAFORMA ACABADA LADO ESQUERDO	PTO	1	2	3	4	5	6	33
	DIST	3,300	3,409	3,618	3,698	3,907	4,016	4,112
	COTA	518,723m	518,723m	518,600m	518,600m	518,723m	518,723m	518,819m

PLATAFORMA ACABADA LADO DIREITO	PTO	1	2	3	4	5	6	33
	DIST	3,300m	3,409m	3,618m	3,698m	3,907m	4,016m	4,116m
	COTA	518,723m	518,723m	518,600m	518,600m	518,723m	518,723m	518,623m

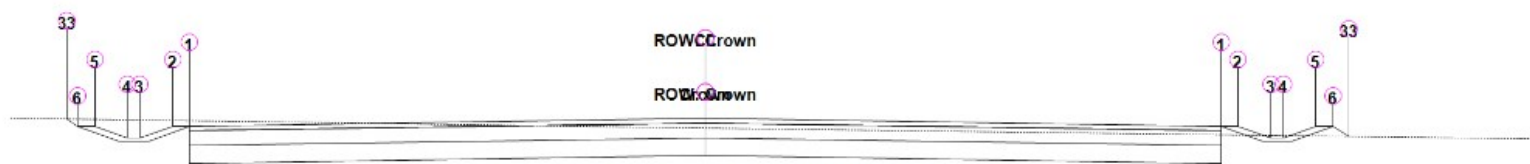

ALINHAMENTO LEOBERTO LEAL SC-408

Estaca: 0+362,16

Área de Corte: 2,25m<sup>2</sup>  
 Área de Aterro: 0,02m<sup>2</sup>  
 Volume Acumulado: 2.373,15m<sup>3</sup>  
 Cota Projeto: 518,737m

PLATAFORMA ACABADA LADO ESQUERDO	PTO	1	2	3	4	5	6	33
	DIST	3,300	3,409	3,618	3,698	3,907	4,016	4,083
	COTA	518,655m	518,655m	518,532m	518,532m	518,655m	518,655m	518,723m

PLATAFORMA ACABADA LADO DIREITO	PTO	1	2	3	4	5	6	33
	DIST	3,300m	3,409m	3,618m	3,698m	3,907m	4,016m	4,119m
	COTA	518,655m	518,655m	518,532m	518,532m	518,655m	518,655m	518,552m

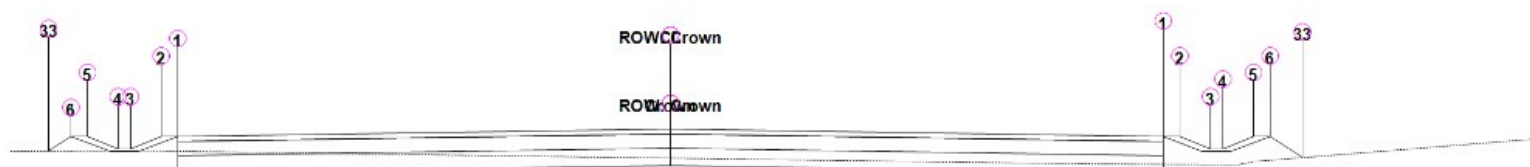

ALINHAMENTO LEOBERTO LEAL SC-408

Estaca: 0+380,00

Área de Corte: 0,79m<sup>2</sup>  
 Área de Aterro: 0,20m<sup>2</sup>  
 Volume Acumulado: 2.398,45m<sup>3</sup>  
 Cota Projeto: 518,369m

PLATAFORMA ACABADA LADO ESQUERDO	PTO	1	2	3	4	5	6	33
	DIST	3,300	3,409	3,618	3,698	3,907	4,016	4,164
	COTA	518,286m	518,286m	518,163m	518,163m	518,286m	518,286m	518,137m

PLATAFORMA ACABADA LADO DIREITO	PTO	1	2	3	4	5	6	33
	DIST	3,300m	3,409m	3,618m	3,698m	3,907m	4,016m	4,231m
	COTA	518,286m	518,286m	518,163m	518,163m	518,286m	518,286m	518,070m



ALINHAMENTO LEOBERTO LEAL SC-408

Estaca: 0+389,59

Área de Corte: 0,44m<sup>2</sup>  
 Área de Aterro: 0,31m<sup>2</sup>  
 Volume Acumulado: 2.402,02m<sup>3</sup>  
 Cota Projeto: 518,249m

PLATAFORMA ACABADA LADO ESQUERDO	PTO	1	2	3	4	5	6	33
	DIST	4,405	4,514	4,724	4,804	5,013	5,121	5,355
	COTA	518,139m	518,139m	518,016m	518,016m	518,139m	518,139m	517,904m

PLATAFORMA ACABADA LADO DIREITO	PTO	1	2	3	4	5	6	33
	DIST	3,300m	3,409m	3,618m	3,698m	3,907m	4,016m	4,209m
	COTA	518,166m	518,166m	518,043m	518,043m	518,166m	518,166m	517,973m



ALINHAMENTO LEOBERTO LEAL SC-408

Estaca: 0+400,00

Área de Corte: 0,69m<sup>2</sup>  
 Área de Aterro: 0,38m<sup>2</sup>  
 Volume Acumulado: 2.404,28m<sup>3</sup>  
 Cota Projeto: 518,119m

PLATAFORMA ACABADA LADO ESQUERDO	PTO	1	2	3	4	5	6	33
	DIST	6,077	6,186	6,395	6,475	6,684	6,792	6,884
	COTA	517,967m	517,967m	517,844m	517,844m	517,967m	517,967m	517,875m

PLATAFORMA ACABADA LADO DIREITO	PTO	1	2	3	4	5	6	33
	DIST	3,300m	3,409m	3,618m	3,698m	3,907m	4,016m	4,162m
	COTA	518,036m	518,036m	517,913m	517,913m	518,036m	518,036m	517,890m



ALINHAMENTO LEOBERTO LEAL SC-408

Estaca: 0+420,00

Área de Corte: 0,79m<sup>2</sup>  
 Área de Aterro: 0,44m<sup>2</sup>  
 Volume Acumulado: 2.410,89m<sup>3</sup>  
 Cota Projeto: 517,869m

PLATAFORMA ACABADA LADO ESQUERDO	PTO	1	2	3	4	5	6	33
	DIST	6,357	6,466	6,675	6,755	6,964	7,073	7,080
	COTA	517,710m	517,710m	517,587m	517,587m	517,710m	517,710m	517,718m

PLATAFORMA ACABADA LADO DIREITO	PTO	1	2	3	4	5	6	33
	DIST	3,300m	3,409m	3,618m	3,698m	3,907m	4,016m	4,265m
	COTA	517,786m	517,786m	517,663m	517,663m	517,786m	517,786m	517,537m

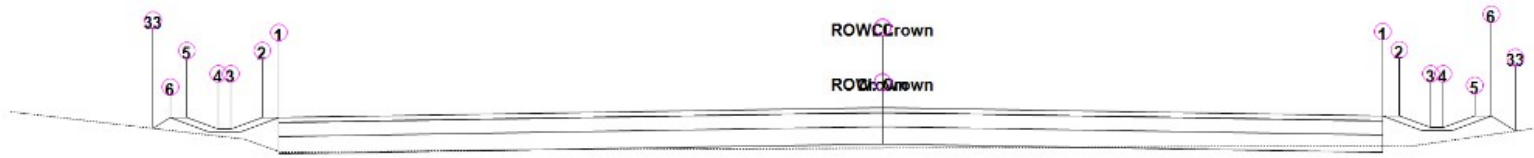

ALINHAMENTO LEOBERTO LEAL SC-408

Estaca: 0+440,00

Área de Corte: 0,09m<sup>2</sup>  
 Área de Aterro: 0,30m<sup>2</sup>  
 Volume Acumulado: 2.412,40m<sup>3</sup>  
 Cota Projeto: 517,619m

PLATAFORMA ACABADA LADO ESQUERDO	PTO	1	2	3	4	5	6	33
	DIST	3,977	4,086	4,295	4,375	4,584	4,693	4,806
	COTA	517,520m	517,520m	517,397m	517,397m	517,520m	517,520m	517,406m

PLATAFORMA ACABADA LADO DIREITO	PTO	1	2	3	4	5	6	33
	DIST	3,300m	3,409m	3,618m	3,698m	3,907m	4,016m	4,172m
	COTA	517,537m	517,537m	517,414m	517,414m	517,537m	517,537m	517,380m



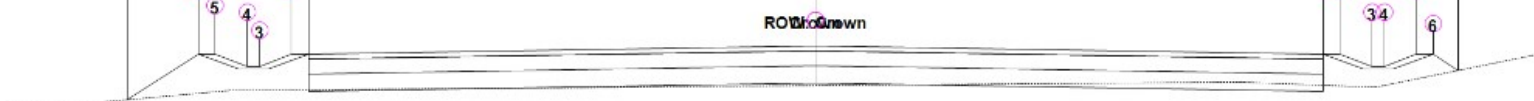

ALINHAMENTO LEOBERTO LEAL SC-408

Estaca: 0+460,00

Área de Corte: 0,13m<sup>2</sup>  
 Área de Aterro: 0,48m<sup>2</sup>  
 Volume Acumulado: 2.406,89m<sup>3</sup>  
 Cota Projeto: 517,369m

PLATAFORMA ACABADA LADO ESQUERDO	PTO	1	2	3	4	5	6	33
	DIST	3,300	3,409	3,618	3,698	3,907	4,016	4,480
	COTA	517,287m	517,287m	517,164m	517,164m	517,287m	517,287m	516,823m

PLATAFORMA ACABADA LADO DIREITO	PTO	1	2	3	4	5	6	33
	DIST	3,300m	3,409m	3,618m	3,698m	3,907m	4,016m	4,181m
	COTA	517,287m	517,287m	517,164m	517,164m	517,287m	517,287m	517,121m

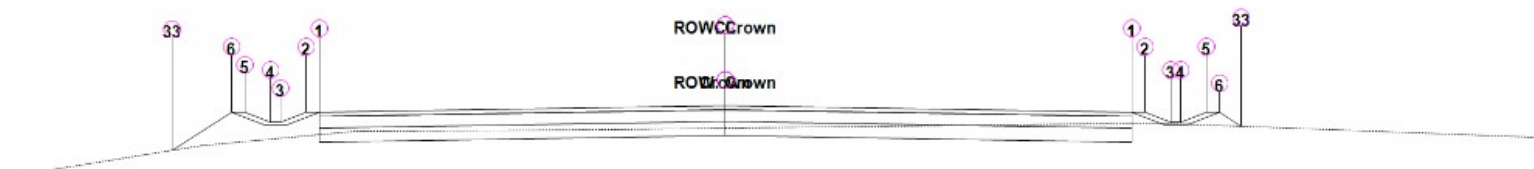

ALINHAMENTO LEOBERTO LEAL SC-408

Estaca: 0+480,00

Área de Corte: 0,91m<sup>2</sup>  
 Área de Aterro: 0,31m<sup>2</sup>  
 Volume Acumulado: 2.409,41m<sup>3</sup>  
 Cota Projeto: 517,120m

PLATAFORMA ACABADA LADO ESQUERDO	PTO	1	2	3	4	5	6	33
	DIST	3,300	3,409	3,618	3,698	3,907	4,016	4,499
	COTA	517,037m	517,037m	516,914m	516,914m	517,037m	517,037m	516,554m

PLATAFORMA ACABADA LADO DIREITO	PTO	1	2	3	4	5	6	33
	DIST	3,300m	3,409m	3,618m	3,698m	3,907m	4,016m	4,194m
	COTA	517,037m	517,037m	516,914m	516,914m	517,037m	517,037m	516,859m

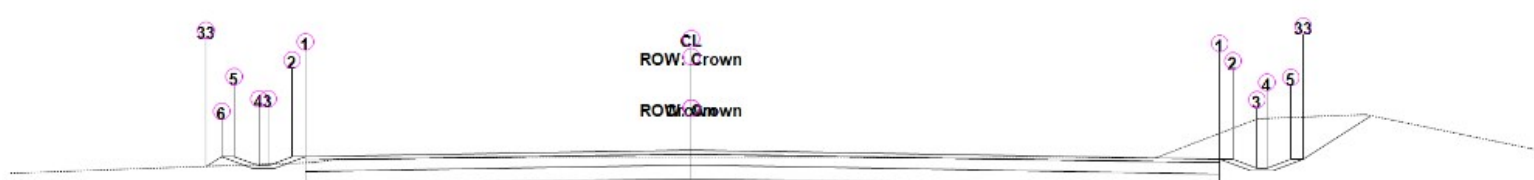

ALINHAMENTO LEOBERTO LEAL SC-408

Estaca: 0+500,00

Área de Corte: 3,22m<sup>2</sup>

Área de Aterro: 0,03m<sup>2</sup>  
 Volume Acumulado: 2.447,35m<sup>3</sup>  
 Cota Projeto: 516,870m

PLATAFORMA ACABADA LADO ESQUERDO	PTO	1	2	3	4	5	6	33
	DIST	3,300	3,409	3,618	3,698	3,907	4,016	4,149
	COTA	516,787m	516,787m	516,664m	516,664m	516,787m	516,787m	516,654m

PLATAFORMA ACABADA LADO DIREITO	PTO	1	2	3	4	5	33
	DIST	4,520m	4,629m	4,838m	4,918m	5,127m	5,236m
	COTA	516,757m	516,757m	516,634m	516,634m	516,757m	516,757m



ALINHAMENTO LEOBERTO LEAL SC-408

Estaca: 0+520,00

Área de Corte: 5,09m<sup>2</sup>  
 Área de Aterro: 0,00m<sup>2</sup>  
 Volume Acumulado: 2.530,19m<sup>3</sup>  
 Cota Projeto: 516,620m

PLATAFORMA ACABADA LADO ESQUERDO	PTO	1	2	3	4	5	6	33
	DIST	3,300	3,409	3,618	3,698	3,907	4,016	4,151
	COTA	516,538m	516,538m	516,415m	516,415m	516,538m	516,538m	516,673m

PLATAFORMA ACABADA LADO DIREITO	PTO	1	2	3	4	5	6	33
	DIST	6,345m	6,345m	6,454m	6,663m	6,743m	6,952m	7,061m
	COTA	516,461m	516,462m	516,461m	516,338m	516,338m	516,461m	516,461m

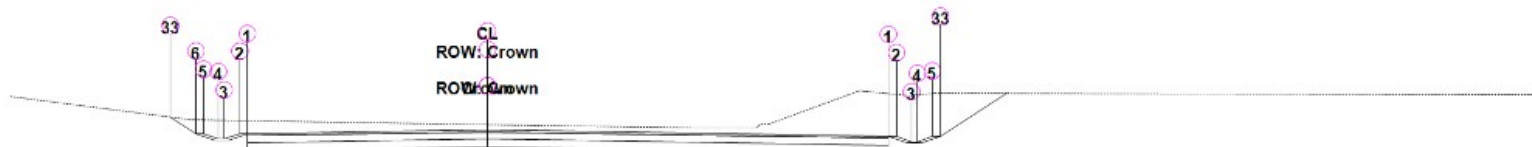

ALINHAMENTO LEOBERTO LEAL SC-408

Estaca: 0+540,00

Área de Corte: 6,99m<sup>2</sup>  
 Área de Aterro: 0,00m<sup>2</sup>  
 Volume Acumulado: 2.651,02m<sup>3</sup>  
 Cota Projeto: 516,370m

PLATAFORMA ACABADA LADO ESQUERDO	PTO	1	2	3	4	5	6	33
	DIST	3,300	3,409	3,618	3,698	3,907	4,016	4,362
	COTA	516,288m	516,288m	516,165m	516,165m	516,288m	516,288m	516,634m



PLATAFORMA ACABADA LADO DIREITO	PTO	1	2	3	4	5	33
	DIST	5,516m	5,625m	5,834m	5,914m	6,123m	6,231m
	COTA	516,232m	516,232m	516,109m	516,109m	516,232m	516,232m

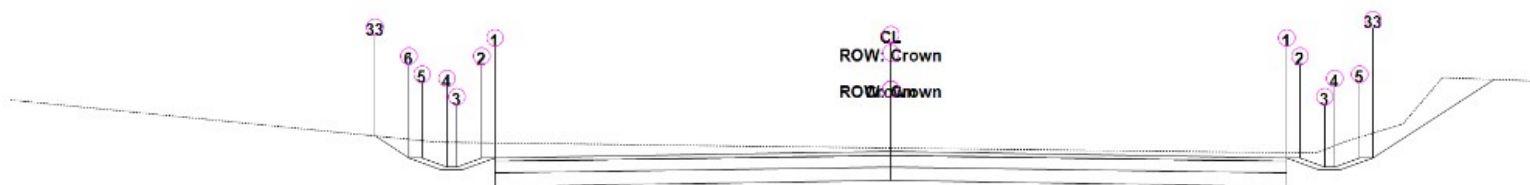

ALINHAMENTO LEOBERTO LEAL SC-408

Estaca: 0+560,00

Área de Corte: 3,80m<sup>2</sup>  
 Área de Aterro: 0,00m<sup>2</sup>  
 Volume Acumulado: 2.758,99m<sup>3</sup>  
 Cota Projeto: 516,121m

PLATAFORMA ACABADA LADO ESQUERDO	PTO	1	2	3	4	5	6	33
	DIST	3,300	3,409	3,618	3,698	3,907	4,016	4,301
	COTA	516,038m	516,038m	515,915m	515,915m	516,038m	516,038m	516,323m

PLATAFORMA ACABADA LADO DIREITO	PTO	1	2	3	4	5	33
	DIST	3,300m	3,409m	3,618m	3,698m	3,907m	4,016m
	COTA	516,038m	516,038m	515,915m	515,915m	516,038m	516,038m

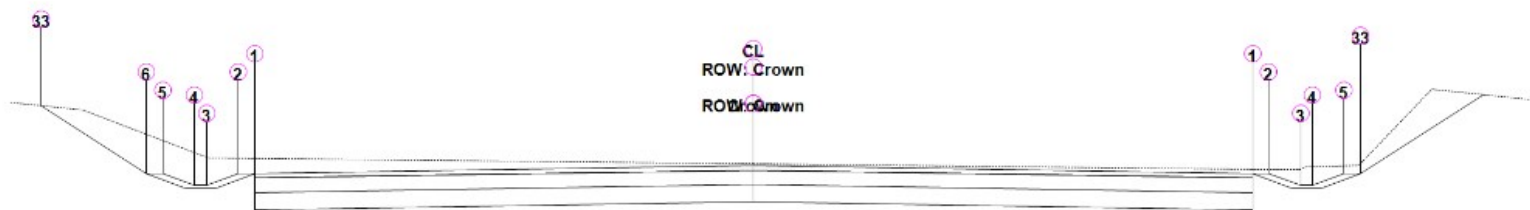

ALINHAMENTO LEOBERTO LEAL SC-408

Estaca: 0+580,00

Área de Corte: 3,58m<sup>2</sup>  
 Área de Aterro: 0,00m<sup>2</sup>  
 Volume Acumulado: 2.832,81m<sup>3</sup>  
 Cota Projeto: 515,871m

PLATAFORMA ACABADA LADO ESQUERDO	PTO	1	2	3	4	5	6	33
	DIST	3,300	3,409	3,618	3,698	3,907	4,016	4,711
	COTA	515,788m	515,788m	515,665m	515,665m	515,788m	515,788m	516,484m

PLATAFORMA ACABADA LADO DIREITO	PTO	1	2	3	4	5	33
	DIST	3,300m	3,409m	3,618m	3,698m	3,907m	4,016m
	COTA	515,788m	515,788m	515,665m	515,665m	515,788m	515,788m

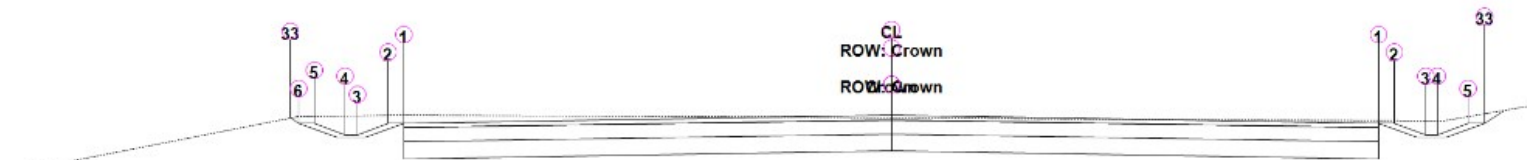

ALINHAMENTO LEOBERTO LEAL SC-408

Estaca: 0+600,00

Área de Corte: 2,83m<sup>2</sup>  
 Área de Aterro: 0,00m<sup>2</sup>  
 Volume Acumulado: 2.896,88m<sup>3</sup>  
 Cota Projeto: 515,631m

PLATAFORMA ACABADA LADO ESQUERDO	PTO	1	2	3	4	5	6	33
	DIST	3,300	3,409	3,618	3,698	3,907	4,016	4,073
	COTA	515,549m	515,549m	515,426m	515,426m	515,549m	515,549m	515,606m

PLATAFORMA ACABADA LADO DIREITO	PTO	1	2	3	4	5	33
	DIST	3,300m	3,409m	3,618m	3,698m	3,907m	4,016m
	COTA	515,549m	515,549m	515,426m	515,426m	515,549m	515,549m



ALINHAMENTO LEOBERTO LEAL SC-408

Estaca: 0+620,00

Área de Corte: 2,11m<sup>2</sup>  
 Área de Aterro: 0,01m<sup>2</sup>  
 Volume Acumulado: 2.946,10m<sup>3</sup>  
 Cota Projeto: 515,418m

PLATAFORMA ACABADA LADO ESQUERDO	PTO	1	2	3	4	5	6	33
	DIST	3,300	3,409	3,618	3,698	3,907	4,016	4,108
	COTA	515,336m	515,336m	515,213m	515,213m	515,336m	515,336m	515,243m

PLATAFORMA ACABADA LADO DIREITO	PTO	1	2	3	4	5	6	33
	DIST	3,300m	3,409m	3,618m	3,698m	3,907m	4,016m	4,067m
	COTA	515,336m	515,336m	515,213m	515,213m	515,336m	515,336m	515,285m

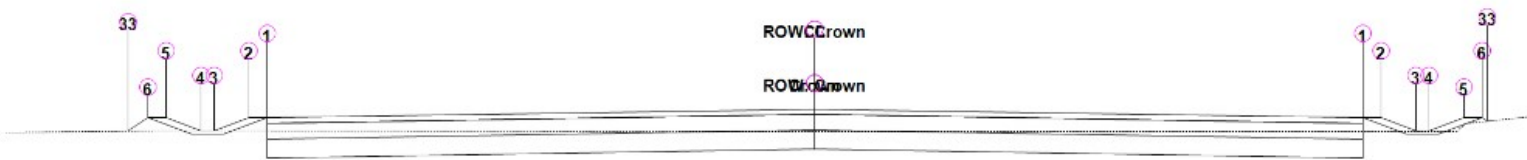

ALINHAMENTO LEOBERTO LEAL SC-408

Estaca: 0+637,52

Área de Corte: 1,40m<sup>2</sup>  
 Área de Aterro: 0,05m<sup>2</sup>  
 Volume Acumulado: 2.976,21m<sup>3</sup>  
 Cota Projeto: 515,253m

PLATAFORMA ACABADA LADO ESQUERDO	PTO	1	2	3	4	5	6	33
	DIST	3,300	3,409	3,618	3,698	3,907	4,016	4,139
	COTA	515,171m	515,171m	515,048m	515,048m	515,171m	515,171m	515,048m

PLATAFORMA ACABADA LADO DIREITO	PTO	1	2	3	4	5	6	33
	DIST	3,300m	3,409m	3,618m	3,698m	3,907m	4,016m	4,048m
	COTA	515,171m	515,171m	515,048m	515,048m	515,171m	515,171m	515,138m

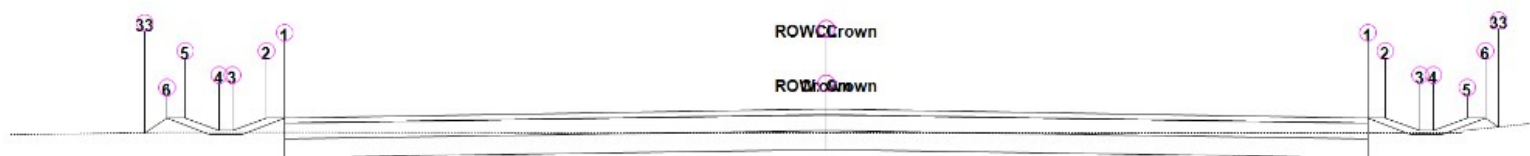

ALINHAMENTO LEOBERTO LEAL SC-408

Estaca: 0+640,00

Área de Corte: 1,31m<sup>2</sup>  
 Área de Aterro: 0,08m<sup>2</sup>  
 Volume Acumulado: 2.979,41m<sup>3</sup>  
 Cota Projeto: 515,232m

PLATAFORMA ACABADA LADO ESQUERDO	PTO	1	2	3	4	5	6	33
	DIST	3,300	3,409	3,618	3,698	3,907	4,016	4,155
	COTA	515,149m	515,149m	515,026m	515,026m	515,149m	515,149m	515,010m

PLATAFORMA ACABADA LADO DIREITO	PTO	1	2	3	4	5	6	33
	DIST	3,300m	3,409m	3,618m	3,698m	3,907m	4,016m	4,101m
	COTA	515,149m	515,149m	515,026m	515,026m	515,149m	515,149m	515,064m

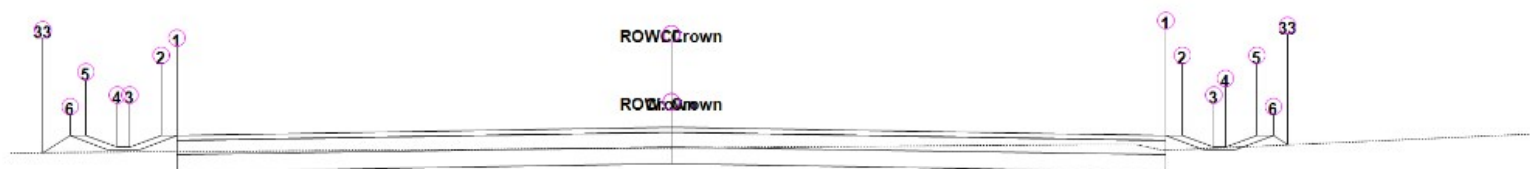

ALINHAMENTO LEOBERTO LEAL SC-408

Estaca: 0+660,00

Área de Corte: 1,37m<sup>2</sup>  
 Área de Aterro: 0,11m<sup>2</sup>  
 Volume Acumulado: 3.004,39m<sup>3</sup>  
 Cota Projeto: 515,071m

PLATAFORMA	PTO	1	2	3	4	5	6	33
------------	-----	---	---	---	---	---	---	----

ACABADA LADO ESQUERDO	DIST	3,300	3,409	3,618	3,698	3,907	4,016	4,198
	COTA	514,989m	514,989m	514,866m	514,866m	514,989m	514,989m	514,806m

PLATAFORMA ACABADA LADO DIREITO	PTO	1	2	3	4	5	6	33
	DIST	3,300m	3,409m	3,618m	3,698m	3,907m	4,016m	4,113m
	COTA	514,989m	514,989m	514,866m	514,866m	514,989m	514,989m	514,891m

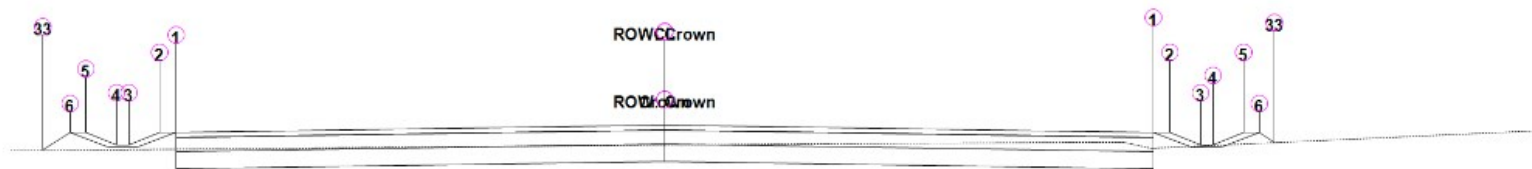

ALINHAMENTO LEOBERTO LEAL SC-408

Estaca: 0+660,05

Área de Corte: 1,37m<sup>2</sup>  
 Área de Aterro: 0,11m<sup>2</sup>  
 Volume Acumulado: 3.004,45m<sup>3</sup>  
 Cota Projeto: 515,071m

PLATAFORMA ACABADA LADO ESQUERDO	PTO	1	2	3	4	5	6	33
	DIST	3,300	3,409	3,618	3,698	3,907	4,016	4,198
	COTA	514,988m	514,988m	514,865m	514,865m	514,988m	514,988m	514,806m

PLATAFORMA ACABADA LADO DIREITO	PTO	1	2	3	4	5	6	33
	DIST	3,300m	3,409m	3,618m	3,698m	3,907m	4,016m	4,116m
	COTA	514,988m	514,988m	514,865m	514,865m	514,988m	514,988m	514,888m

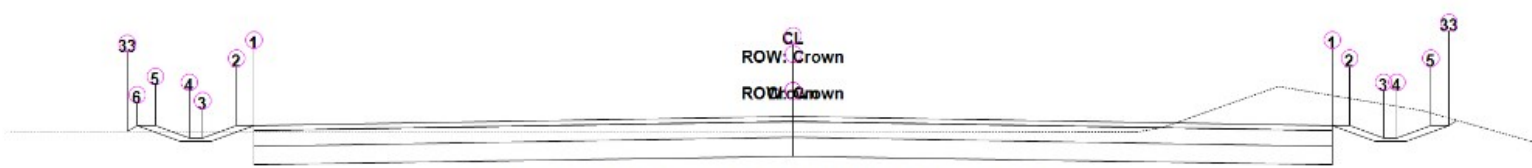

ALINHAMENTO LEOBERTO LEAL SC-408

Estaca: 0+680,00

Área de Corte: 2,35m<sup>2</sup>  
 Área de Aterro: 0,01m<sup>2</sup>  
 Volume Acumulado: 3.040,50m<sup>3</sup>  
 Cota Projeto: 514,937m

PLATAFORMA ACABADA LADO ESQUERDO	PTO	1	2	3	4	5	6	33
	DIST	3,300	3,409	3,618	3,698	3,907	4,016	4,079
	COTA	514,855m	514,855m	514,732m	514,732m	514,855m	514,855m	514,792m

PLATAFORMA ACABADA LADO DIREITO	PTO	1	2	3	4	5	33
	DIST	3,300m	3,409m	3,618m	3,698m	3,907m	4,016m
	COTA	514,855m	514,855m	514,732m	514,732m	514,855m	514,855m

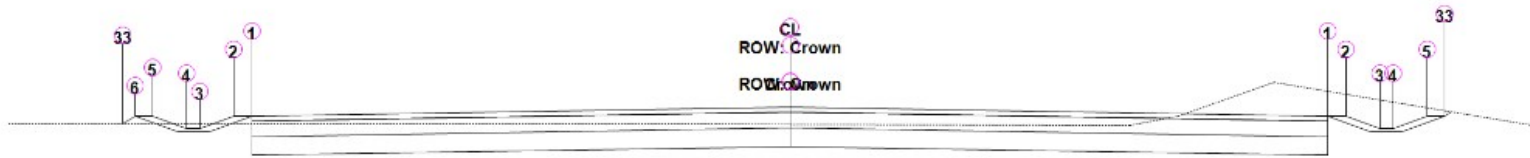

ALINHAMENTO LEOBERTO LEAL SC-408

Estaca: 0+682,58

Área de Corte: 2,17m<sup>2</sup>  
 Área de Aterro: 0,01m<sup>2</sup>  
 Volume Acumulado: 3.046,31m<sup>3</sup>  
 Cota Projeto: 514,922m

PLATAFORMA ACABADA LADO ESQUERDO	PTO	1	2	3	4	5	6	33
	DIST	3,300	3,409	3,618	3,698	3,907	4,016	4,093
	COTA	514,840m	514,840m	514,717m	514,717m	514,840m	514,840m	514,763m

PLATAFORMA ACABADA LADO DIREITO	PTO	1	2	3	4	5	33
	DIST	3,300m	3,409m	3,618m	3,698m	3,907m	4,016m
	COTA	514,840m	514,840m	514,717m	514,717m	514,840m	514,840m

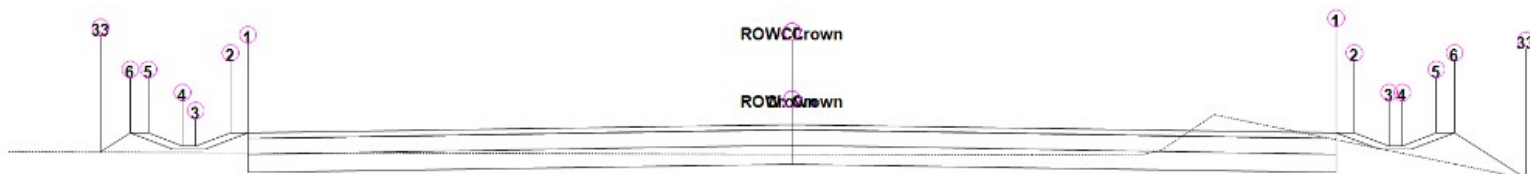

ALINHAMENTO LEOBERTO LEAL SC-408

Estaca: 0+697,18

Área de Corte: 1,17m<sup>2</sup>  
 Área de Aterro: 0,20m<sup>2</sup>  
 Volume Acumulado: 3.069,12m<sup>3</sup>  
 Cota Projeto: 514,844m

PLATAFORMA ACABADA LADO ESQUERDO	PTO	1	2	3	4	5	6	33
	DIST	3,300	3,409	3,618	3,698	3,907	4,016	4,197
	COTA	514,761m	514,761m	514,638m	514,638m	514,761m	514,761m	514,579m

PLATAFORMA ACABADA LADO DIREITO	PTO	1	2	3	4	5	6	33
	DIST	3,300m	3,409m	3,618m	3,698m	3,907m	4,016m	4,451m
	COTA	514,761m	514,761m	514,638m	514,638m	514,761m	514,761m	514,326m

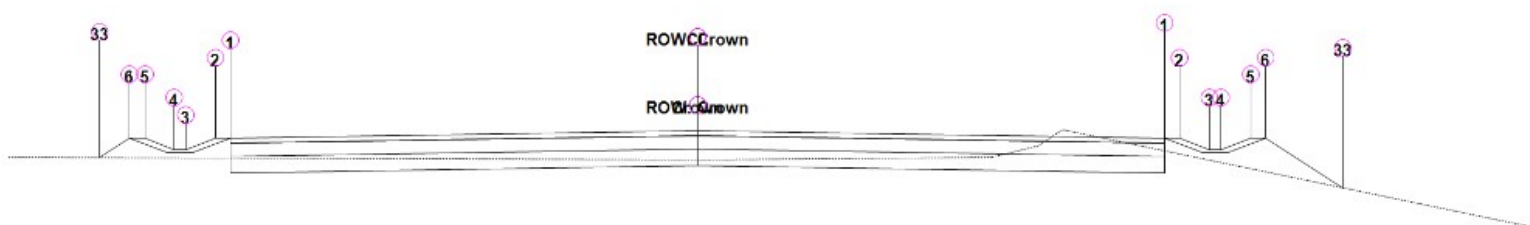

ALINHAMENTO LEOBERTO LEAL SC-408

Estaca: 0+700,00

Área de Corte: 0,98m<sup>2</sup>  
 Área de Aterro: 0,32m<sup>2</sup>  
 Volume Acumulado: 3.071,42m<sup>3</sup>  
 Cota Projeto: 514,830m

PLATAFORMA ACABADA LADO ESQUERDO	PTO	1	2	3	4	5	6	33
	DIST	3,300	3,409	3,618	3,698	3,907	4,016	4,225
	COTA	514,748m	514,748m	514,625m	514,625m	514,748m	514,748m	514,539m

PLATAFORMA ACABADA LADO DIREITO	PTO	1	2	3	4	5	6	33
	DIST	3,300m	3,409m	3,618m	3,698m	3,907m	4,016m	4,558m
	COTA	514,748m	514,748m	514,625m	514,625m	514,748m	514,748m	514,205m

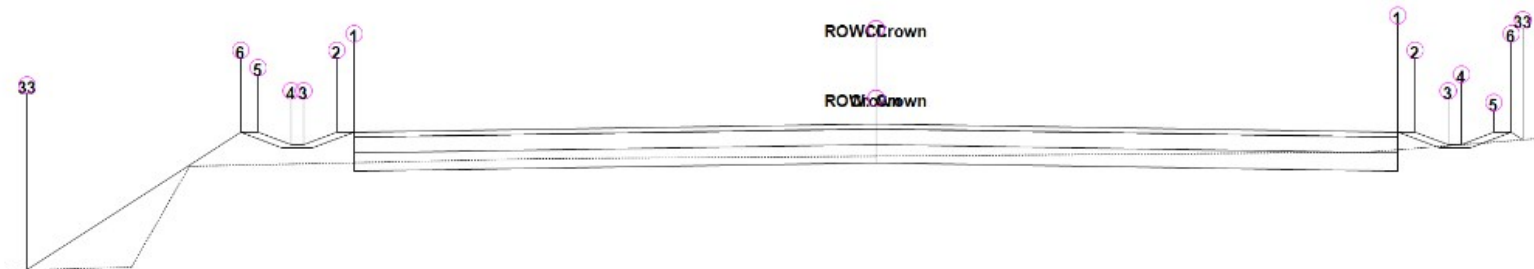

ALINHAMENTO LEOBERTO LEAL SC-408

Estaca: 0+716,06

Área de Corte: 0,67m<sup>2</sup>  
 Área de Aterro: 0,56m<sup>2</sup>  
 Volume Acumulado: 3.077,93m<sup>3</sup>  
 Cota Projeto: 514,763m

PLATAFORMA ACABADA LADO ESQUERDO	PTO	1	2	3	4	5	6	33
	DIST	3,300	3,409	3,618	3,698	3,907	4,016	5,365
	COTA	514,681m	514,681m	514,558m	514,558m	514,681m	514,681m	513,331m

PLATAFORMA ACABADA LADO DIREITO	PTO	1	2	3	4	5	6	33
	DIST	3,300m	3,409m	3,618m	3,698m	3,907m	4,016m	4,090m
	COTA	514,681m	514,681m	514,558m	514,558m	514,681m	514,681m	514,607m

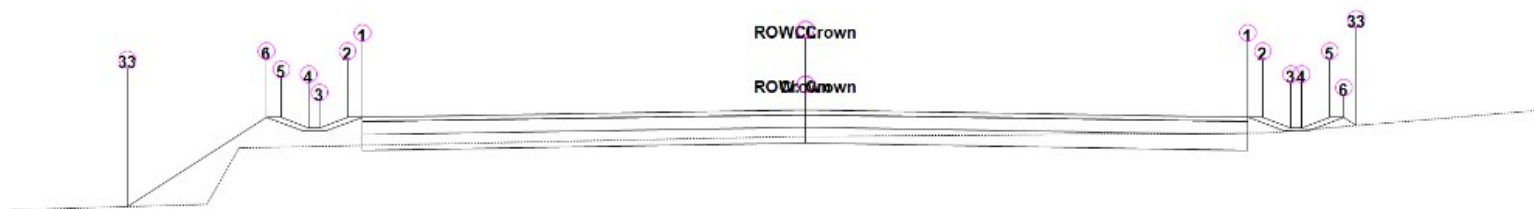

ALINHAMENTO LEOBERTO LEAL SC-408

Estaca: 0+720,00

Área de Corte: 0,67m<sup>2</sup>  
 Área de Aterro: 0,52m<sup>2</sup>

Volume Acumulado: 3.078,59m<sup>3</sup>  
 Cota Projeto: 514,749m

PLATAFORMA ACABADA LADO ESQUERDO	PTO	1	2	3	4	5	6	33
	DIST	3,300	3,409	3,618	3,698	3,907	4,016	5,052
	COTA	514,667m	514,667m	514,544m	514,544m	514,667m	514,667m	513,631m

PLATAFORMA ACABADA LADO DIREITO	PTO	1	2	3	4	5	6	33
	DIST	3,300m	3,409m	3,618m	3,698m	3,907m	4,016m	4,108m
	COTA	514,667m	514,667m	514,544m	514,544m	514,667m	514,667m	514,574m

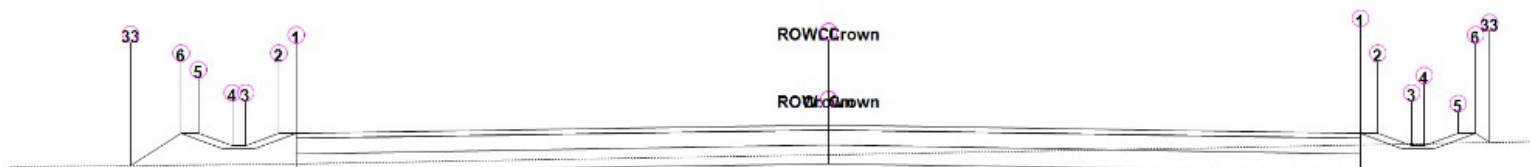

ALINHAMENTO LEOBERTO LEAL SC-408

Estaca: 0+734,94

Área de Corte: 0,88m<sup>2</sup>  
 Área de Aterro: 0,22m<sup>2</sup>  
 Volume Acumulado: 3.085,06m<sup>3</sup>  
 Cota Projeto: 514,706m

PLATAFORMA ACABADA LADO ESQUERDO	PTO	1	2	3	4	5	6	33
	DIST	3,300	3,409	3,618	3,698	3,907	4,016	4,332
	COTA	514,623m	514,623m	514,500m	514,500m	514,623m	514,623m	514,307m

PLATAFORMA ACABADA LADO DIREITO	PTO	1	2	3	4	5	6	33
	DIST	3,300m	3,409m	3,618m	3,698m	3,907m	4,016m	4,104m
	COTA	514,623m	514,623m	514,500m	514,500m	514,623m	514,623m	514,535m



ALINHAMENTO LEOBERTO LEAL SC-408

Estaca: 0+740,00

Área de Corte: 1,30m<sup>2</sup>  
 Área de Aterro: 0,14m<sup>2</sup>  
 Volume Acumulado: 3.089,69m<sup>3</sup>  
 Cota Projeto: 514,695m

PLATAFORMA ACABADA LADO ESQUERDO	PTO	1	2	3	4	5	6	33
	DIST	3,300	3,409	3,618	3,698	3,907	4,016	4,270
	COTA	514,612m	514,612m	514,489m	514,489m	514,612m	514,612m	514,358m

PLATAFORMA	PTO	1	2	3	4	5	6	33
------------	-----	---	---	---	---	---	---	----

ACABADA	DIST	3,300m	3,409m	3,618m	3,698m	3,907m	4,016m	4,068m
LADO DIREITO	COTA	514,612m	514,612m	514,489m	514,489m	514,612m	514,612m	514,560m

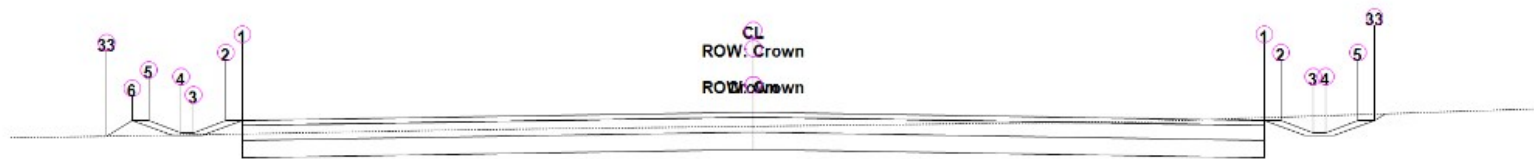

ALINHAMENTO LEOBERTO LEAL SC-408

Estaca: 0+760,00

Área de Corte: 1,96m<sup>2</sup>  
 Área de Aterro: 0,05m<sup>2</sup>  
 Volume Acumulado: 3.120,43m<sup>3</sup>  
 Cota Projeto: 514,667m

PLATAFORMA ACABADA LADO ESQUERDO	PTO	1	2	3	4	5	6	33
	DIST	3,300	3,409	3,618	3,698	3,907	4,016	4,177
	COTA	514,584m	514,584m	514,461m	514,461m	514,584m	514,584m	514,423m

PLATAFORMA ACABADA LADO DIREITO	PTO	1	2	3	4	5	33
	DIST	3,300m	3,409m	3,618m	3,698m	3,907m	4,016m
	COTA	514,584m	514,584m	514,461m	514,461m	514,584m	514,584m

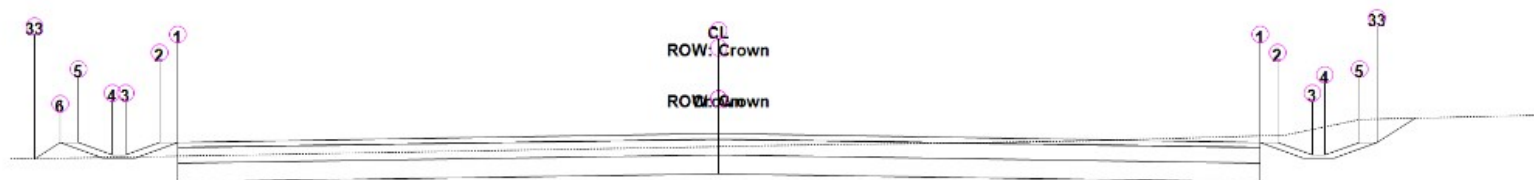

ALINHAMENTO LEOBERTO LEAL SC-408

Estaca: 0+778,09

Área de Corte: 2,16m<sup>2</sup>  
 Área de Aterro: 0,05m<sup>2</sup>  
 Volume Acumulado: 3.156,92m<sup>3</sup>  
 Cota Projeto: 514,664m

PLATAFORMA ACABADA LADO ESQUERDO	PTO	1	2	3	4	5	6	33
	DIST	3,300	3,409	3,618	3,698	3,907	4,016	4,174
	COTA	514,582m	514,582m	514,459m	514,459m	514,582m	514,582m	514,424m

PLATAFORMA ACABADA LADO DIREITO	PTO	1	2	3	4	5	33
	DIST	3,300m	3,409m	3,618m	3,698m	3,907m	4,016m
	COTA	514,582m	514,582m	514,459m	514,459m	514,582m	514,582m







ALINHAMENTO LEOBERTO LEAL SC-408

Estaca: 0+780,00

Área de Corte: 2,17m<sup>2</sup>  
 Área de Aterro: 0,05m<sup>2</sup>  
 Volume Acumulado: 3.160,97m<sup>3</sup>  
 Cota Projeto: 514,665m

PLATAFORMA ACABADA LADO ESQUERDO	PTO	1	2	3	4	5	6	33
	DIST	3,300	3,409	3,618	3,698	3,907	4,016	4,176
	COTA	514,583m	514,583m	514,460m	514,460m	514,583m	514,583m	514,422m

PLATAFORMA ACABADA LADO DIREITO	PTO	1	2	3	4	5	33
	DIST	3,300m	3,409m	3,618m	3,698m	3,907m	4,016m
	COTA	514,583m	514,583m	514,460m	514,460m	514,583m	514,583m

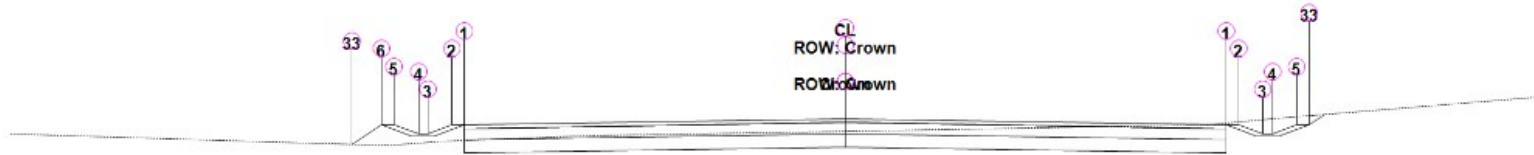

ALINHAMENTO LEOBERTO LEAL SC-408

Estaca: 0+800,00

Área de Corte: 1,80m<sup>2</sup>  
 Área de Aterro: 0,14m<sup>2</sup>  
 Volume Acumulado: 3.198,99m<sup>3</sup>  
 Cota Projeto: 514,680m

PLATAFORMA ACABADA LADO ESQUERDO	PTO	1	2	3	4	5	6	33
	DIST	3,300	3,409	3,618	3,698	3,907	4,016	4,278
	COTA	514,597m	514,597m	514,474m	514,474m	514,597m	514,597m	514,334m

PLATAFORMA ACABADA LADO DIREITO	PTO	1	2	3	4	5	33
	DIST	3,300m	3,409m	3,618m	3,698m	3,907m	4,016m
	COTA	514,597m	514,597m	514,474m	514,474m	514,597m	514,597m



ALINHAMENTO LEOBERTO LEAL SC-408

Estaca: 0+820,00

Área de Corte: 1,44m<sup>2</sup>  
 Área de Aterro: 0,80m<sup>2</sup>  
 Volume Acumulado: 3.222,36m<sup>3</sup>  
 Cota Projeto: 514,694m

PLATAFORMA ACABADA LADO ESQUERDO	PTO	1	2	3	4	5	6	33
	DIST	3,300	3,409	3,618	3,698	3,907	4,016	4,859
	COTA	514,612m	514,612m	514,489m	514,489m	514,612m	514,612m	513,769m

PLATAFORMA ACABADA LADO DIREITO	PTO	1	2	3	4	5	33
	DIST	3,300m	3,409m	3,618m	3,698m	3,907m	4,016m
	COTA	514,612m	514,612m	514,489m	514,489m	514,612m	514,612m

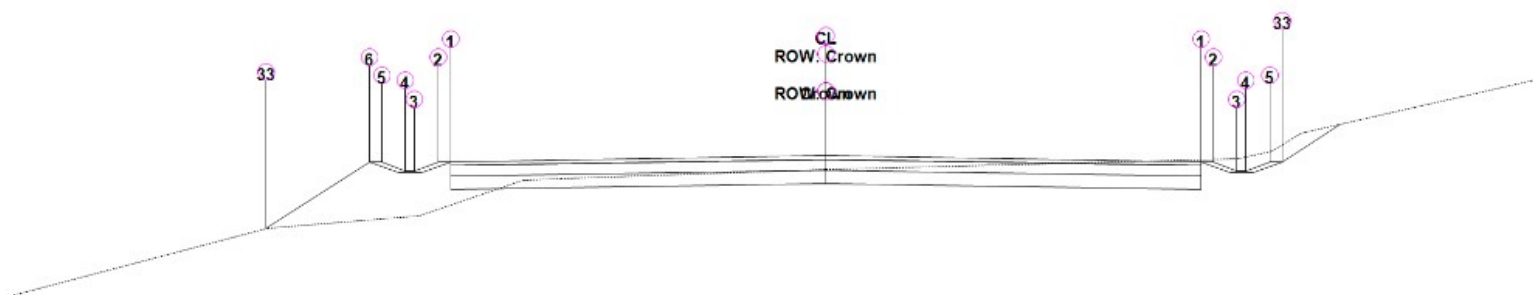

ALINHAMENTO LEOBERTO LEAL SC-408

Estaca: 0+821,24

Área de Corte: 1,62m<sup>2</sup>  
 Área de Aterro: 0,85m<sup>2</sup>  
 Volume Acumulado: 3.223,24m<sup>3</sup>  
 Cota Projeto: 514,695m

PLATAFORMA ACABADA LADO ESQUERDO	PTO	1	2	3	4	5	6	33
	DIST	3,300	3,409	3,618	3,698	3,907	4,016	4,922
	COTA	514,613m	514,613m	514,490m	514,490m	514,613m	514,613m	513,706m

PLATAFORMA ACABADA LADO DIREITO	PTO	1	2	3	4	5	33
	DIST	3,300m	3,409m	3,618m	3,698m	3,907m	4,016m
	COTA	514,613m	514,613m	514,490m	514,490m	514,613m	514,613m

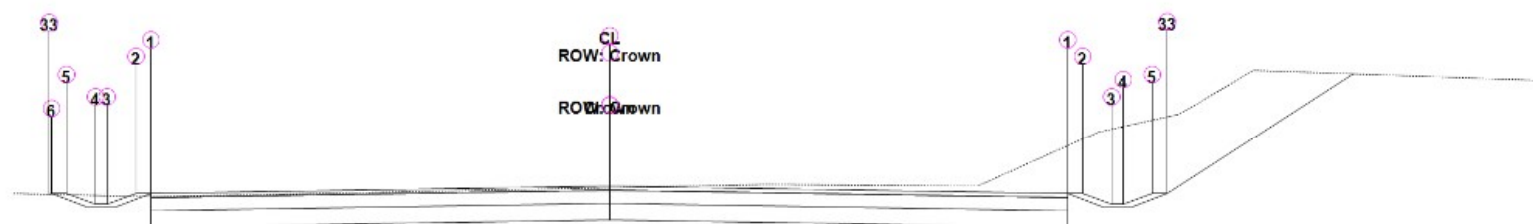

ALINHAMENTO LEOBERTO LEAL SC-408

Estaca: 0+840,00

Área de Corte: 4,11m<sup>2</sup>

Área de Aterro: 0,00m<sup>2</sup>  
 Volume Acumulado: 3.269,09m<sup>3</sup>  
 Cota Projeto: 514,709m

PLATAFORMA ACABADA LADO ESQUERDO	PTO	1	2	3	4	5	6	33
	DIST	3,300	3,409	3,618	3,698	3,907	4,016	4,032
	COTA	514,626m	514,626m	514,503m	514,503m	514,626m	514,626m	514,610m

PLATAFORMA ACABADA LADO DIREITO	PTO	1	2	3	4	5	33
	DIST	3,300m	3,409m	3,618m	3,698m	3,907m	4,016m
	COTA	514,626m	514,626m	514,503m	514,503m	514,626m	514,626m

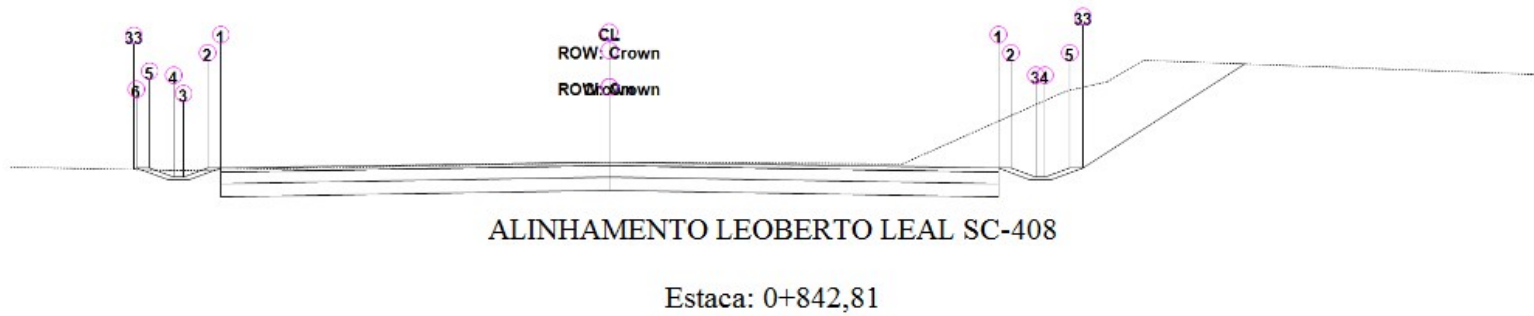

Área de Corte: 4,40m<sup>2</sup>  
 Área de Aterro: 0,00m<sup>2</sup>  
 Volume Acumulado: 3.281,02m<sup>3</sup>  
 Cota Projeto: 514,711m

PLATAFORMA ACABADA LADO ESQUERDO	PTO	1	2	3	4	5	6	33
	DIST	3,300	3,409	3,618	3,698	3,907	4,016	4,037
	COTA	514,628m	514,628m	514,505m	514,505m	514,628m	514,628m	514,607m

PLATAFORMA ACABADA LADO DIREITO	PTO	1	2	3	4	5	33
	DIST	3,300m	3,409m	3,618m	3,698m	3,907m	4,016m
	COTA	514,628m	514,628m	514,505m	514,505m	514,628m	514,628m



Área de Corte: 2,72m<sup>2</sup>  
 Área de Aterro: 0,00m<sup>2</sup>  
 Volume Acumulado: 3.342,13m<sup>3</sup>  
 Cota Projeto: 514,723m

PLATAFORMA ACABADA	PTO	1	2	3	4	5	6	33
--------------------	-----	---	---	---	---	---	---	----

ACABADA	DIST	3,300	3,409	3,618	3,698	3,907	4,016	4,047
LADO								
ESQUERDO	COTA	514,641m	514,641m	514,518m	514,518m	514,641m	514,641m	514,610m

PLATAFORMA ACABADA LADO DIREITO	PTO	1	2	3	4	5	33
	DIST	3,300m	3,409m	3,618m	3,698m	3,907m	4,016m
	COTA	514,641m	514,641m	514,518m	514,518m	514,641m	514,641m

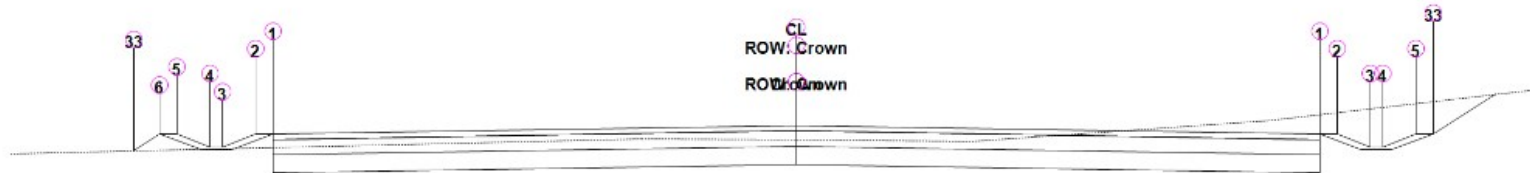

ALINHAMENTO LEOBERTO LEAL SC-408

Estaca: 0+864,37

Área de Corte: 2,35m<sup>2</sup>  
 Área de Aterro: 0,05m<sup>2</sup>  
 Volume Acumulado: 3.353,10m<sup>3</sup>  
 Cota Projeto: 514,727m

PLATAFORMA ACABADA LADO ESQUERDO	PTO	1	2	3	4	5	6	33
	DIST	3,300	3,409	3,618	3,698	3,907	4,016	4,177
	COTA	514,644m	514,644m	514,521m	514,521m	514,644m	514,644m	514,482m

PLATAFORMA ACABADA LADO DIREITO	PTO	1	2	3	4	5	33
	DIST	3,300m	3,409m	3,618m	3,698m	3,907m	4,016m
	COTA	514,644m	514,644m	514,521m	514,521m	514,644m	514,644m



ALINHAMENTO LEOBERTO LEAL SC-408

Estaca: 0+880,00

Área de Corte: 0,70m<sup>2</sup>  
 Área de Aterro: 0,69m<sup>2</sup>  
 Volume Acumulado: 3.370,74m<sup>3</sup>  
 Cota Projeto: 514,738m

PLATAFORMA ACABADA LADO ESQUERDO	PTO	1	2	3	4	5	6	33
	DIST	3,300	3,409	3,618	3,698	3,907	4,016	5,573
	COTA	514,656m	514,656m	514,533m	514,533m	514,656m	514,656m	513,098m

PLATAFORMA ACABADA LADO DIREITO	PTO	1	2	3	4	5	6	33
	DIST	3,300m	3,409m	3,618m	3,698m	3,907m	4,016m	4,385m

LADO DIREITO	COTA	514,656m	514,656m	514,533m	514,533m	514,656m	514,656m	514,286m
--------------	------	----------	----------	----------	----------	----------	----------	----------

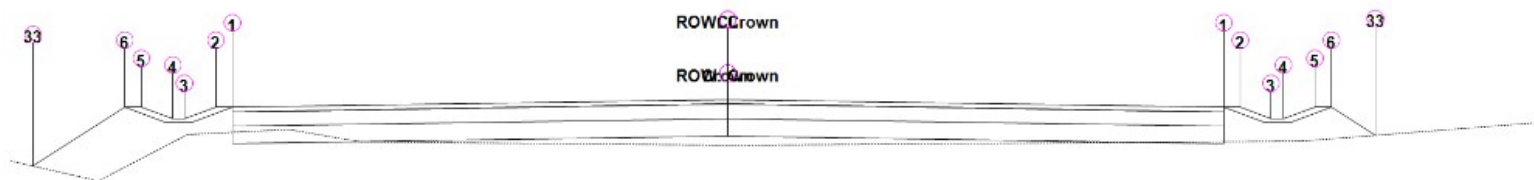

ALINHAMENTO LEOBERTO LEAL SC-408

Estaca: 0+897,72

Área de Corte: 0,09m<sup>2</sup>  
 Área de Aterro: 0,92m<sup>2</sup>  
 Volume Acumulado: 3.363,15m<sup>3</sup>  
 Cota Projeto: 514,839m

PLATAFORMA ACABADA LADO ESQUERDO	PTO	1	2	3	4	5	6	33
	DIST	3,300	3,409	3,618	3,698	3,907	4,016	4,625
	COTA	514,756m	514,756m	514,633m	514,633m	514,756m	514,756m	514,147m

PLATAFORMA ACABADA LADO DIREITO	PTO	1	2	3	4	5	6	33
	DIST	3,300m	3,409m	3,618m	3,698m	3,907m	4,016m	4,309m
	COTA	514,756m	514,756m	514,633m	514,633m	514,756m	514,756m	514,463m

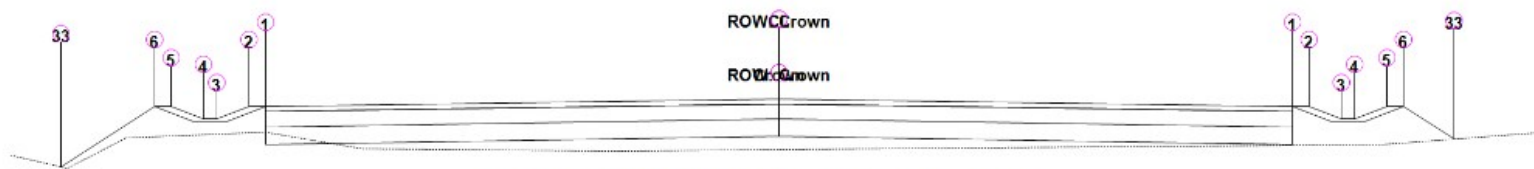

ALINHAMENTO LEOBERTO LEAL SC-408

Estaca: 0+900,00

Área de Corte: 0,03m<sup>2</sup>  
 Área de Aterro: 0,97m<sup>2</sup>  
 Volume Acumulado: 3.361,11m<sup>3</sup>  
 Cota Projeto: 514,870m

PLATAFORMA ACABADA LADO ESQUERDO	PTO	1	2	3	4	5	6	33
	DIST	3,300	3,409	3,618	3,698	3,907	4,016	4,619
	COTA	514,788m	514,788m	514,665m	514,665m	514,788m	514,788m	514,185m

PLATAFORMA ACABADA LADO DIREITO	PTO	1	2	3	4	5	6	33
	DIST	3,300m	3,409m	3,618m	3,698m	3,907m	4,016m	4,340m
	COTA	514,788m	514,788m	514,665m	514,665m	514,788m	514,788m	514,464m

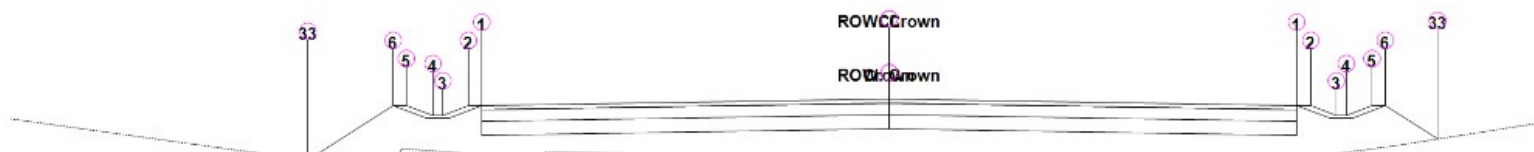

ALINHAMENTO LEOBERTO LEAL SC-408

Estaca: 0+920,00

Área de Corte: 0,00m<sup>2</sup>  
 Área de Aterro: 3,03m<sup>2</sup>  
 Volume Acumulado: 3.321,34m<sup>3</sup>  
 Cota Projeto: 515,336m

PLATAFORMA ACABADA LADO ESQUERDO	PTO	1	2	3	4	5	6	33
	DIST	3,300	3,409	3,618	3,698	3,907	4,016	4,709
	COTA	515,254m	515,254m	515,131m	515,131m	515,254m	515,254m	514,560m

PLATAFORMA ACABADA LADO DIREITO	PTO	1	2	3	4	5	6	33
	DIST	3,300m	3,409m	3,618m	3,698m	3,907m	4,016m	4,441m
	COTA	515,254m	515,254m	515,131m	515,131m	515,254m	515,254m	514,828m

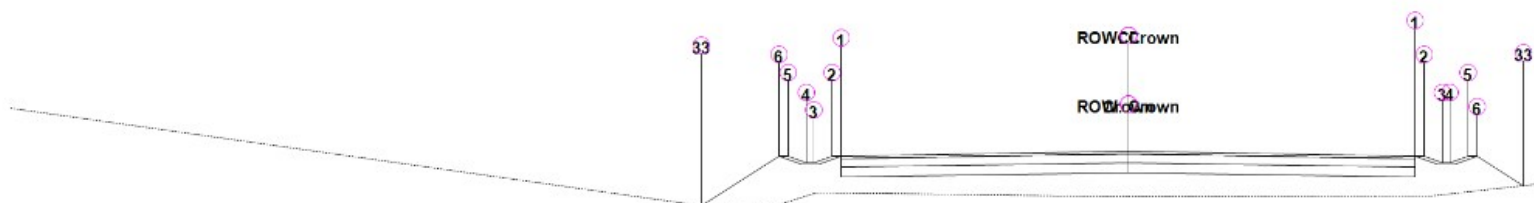

ALINHAMENTO LEOBERTO LEAL SC-408

Estaca: 0+931,06

Área de Corte: 0,00m<sup>2</sup>  
 Área de Aterro: 3,95m<sup>2</sup>  
 Volume Acumulado: 3.282,60m<sup>3</sup>  
 Cota Projeto: 515,739m

PLATAFORMA ACABADA LADO ESQUERDO	PTO	1	2	3	4	5	6	33
	DIST	3,300	3,409	3,618	3,698	3,907	4,016	4,911
	COTA	515,657m	515,657m	515,534m	515,534m	515,657m	515,657m	514,761m

PLATAFORMA ACABADA LADO DIREITO	PTO	1	2	3	4	5	6	33
	DIST	3,300m	3,409m	3,618m	3,698m	3,907m	4,016m	4,550m
	COTA	515,657m	515,657m	515,534m	515,534m	515,657m	515,657m	515,122m

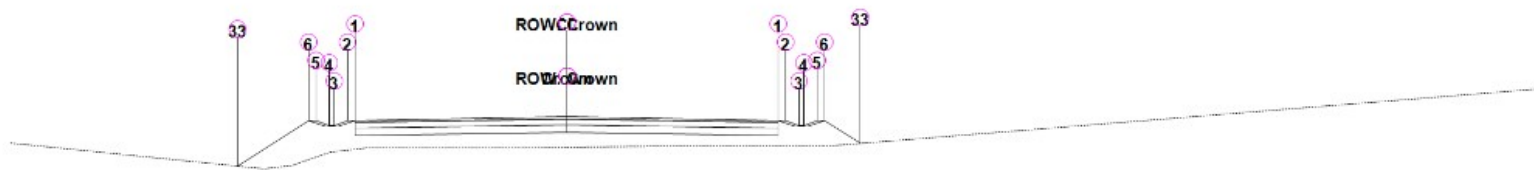

ALINHAMENTO LEOBERTO LEAL SC-408

Estaca: 0+940,00

Área de Corte: 0,00m<sup>2</sup>  
 Área de Aterro: 3,71m<sup>2</sup>  
 Volume Acumulado: 3.248,38m<sup>3</sup>

Cota Projeto: 516,140m

PLATAFORMA ACABADA LADO ESQUERDO	PTO	1	2	3	4	5	6	33
	DIST	3,300	3,409	3,618	3,698	3,907	4,016	5,134
	COTA	516,058m	516,058m	515,935m	515,935m	516,058m	516,058m	514,940m

PLATAFORMA ACABADA LADO DIREITO	PTO	1	2	3	4	5	6	33
	DIST	3,300m	3,409m	3,618m	3,698m	3,907m	4,016m	4,573m
	COTA	516,058m	516,058m	515,935m	515,935m	516,058m	516,058m	515,501m



ALINHAMENTO LEOBERTO LEAL SC-408

Estaca: 0+960,00

Área de Corte: 0,68m<sup>2</sup>  
 Área de Aterro: 0,30m<sup>2</sup>  
 Volume Acumulado: 3.215,12m<sup>3</sup>  
 Cota Projeto: 517,283m

PLATAFORMA ACABADA LADO ESQUERDO	PTO	1	2	3	4	5	6	33
	DIST	3,300	3,409	3,618	3,698	3,907	4,016	4,481
	COTA	517,200m	517,200m	517,077m	517,077m	517,200m	517,200m	516,735m

PLATAFORMA ACABADA LADO DIREITO	PTO	1	2	3	4	5	6	33
	DIST	3,300m	3,409m	3,618m	3,698m	3,907m	4,016m	4,060m
	COTA	517,200m	517,200m	517,077m	517,077m	517,200m	517,200m	517,156m



ALINHAMENTO LEOBERTO LEAL SC-408

Estaca: 0+967,50

Área de Corte: 3,48m<sup>2</sup>  
 Área de Aterro: 0,00m<sup>2</sup>  
 Volume Acumulado: 3.229,62m<sup>3</sup>  
 Cota Projeto: 517,799m

PLATAFORMA ACABADA LADO	PTO	1	2	3	4	5	6	33
	DIST	3,300	3,409	3,618	3,698	3,907	4,016	4,364
	COTA	517,200m	517,200m	517,077m	517,077m	517,200m	517,200m	516,735m

LADO ESQUERDO	COTA	517,716m	517,716m	517,593m	517,593m	517,716m	517,716m	518,065m
---------------	------	----------	----------	----------	----------	----------	----------	----------

PLATAFORMA ACABADA LADO DIREITO	PTO	1	2	3	4	5	33
	DIST	3,300m	3,409m	3,618m	3,698m	3,907m	4,016m
	COTA	517,716m	517,716m	517,593m	517,593m	517,716m	517,716m



ALINHAMENTO LEOBERTO LEAL SC-408

Estaca: 0+980,00

Área de Corte: 7,37m<sup>2</sup>  
 Área de Aterro: 0,00m<sup>2</sup>  
 Volume Acumulado: 3.297,42m<sup>3</sup>  
 Cota Projeto: 518,764m

PLATAFORMA ACABADA LADO ESQUERDO	PTO	1	2	3	4	5	6	33
	DIST	3,300	3,409	3,618	3,698	3,907	4,016	4,820
	COTA	518,681m	518,681m	518,558m	518,558m	518,681m	518,681m	519,486m

PLATAFORMA ACABADA LADO DIREITO	PTO	1	2	3	4	5	33
	DIST	3,300m	3,409m	3,618m	3,698m	3,907m	4,016m
	COTA	518,681m	518,681m	518,558m	518,558m	518,681m	518,681m

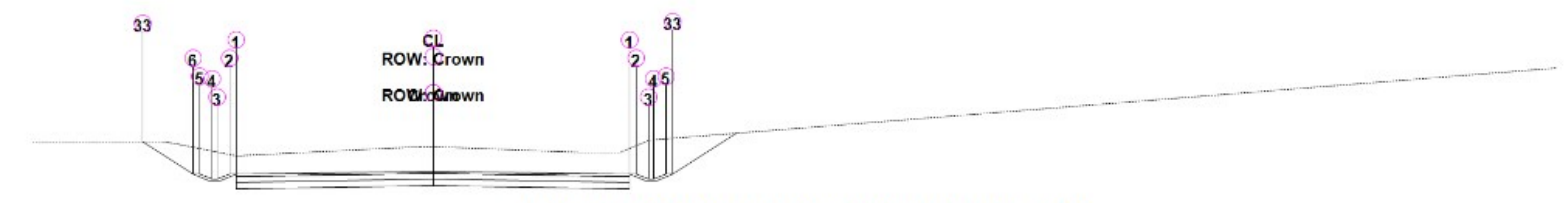

ALINHAMENTO LEOBERTO LEAL SC-408

Estaca: 0+985,31

Área de Corte: 8,34m<sup>2</sup>  
 Área de Aterro: 0,00m<sup>2</sup>  
 Volume Acumulado: 3.339,15m<sup>3</sup>  
 Cota Projeto: 519,214m

PLATAFORMA ACABADA LADO ESQUERDO	PTO	1	2	3	4	5	6	33
	DIST	3,300	3,409	3,618	3,698	3,907	4,016	4,871
	COTA	519,132m	519,132m	519,009m	519,009m	519,132m	519,132m	519,987m

PLATAFORMA ACABADA LADO DIREITO	PTO	1	2	3	4	5	33
	DIST	3,300m	3,409m	3,618m	3,698m	3,907m	4,016m
	COTA	519,132m	519,132m	519,009m	519,009m	519,132m	519,132m



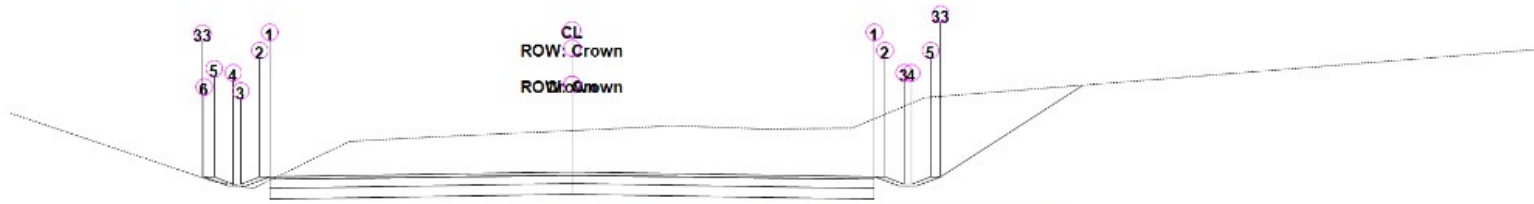

ALINHAMENTO LEOBERTO LEAL SC-408

Estaca: 1+000,00

Área de Corte: 8,93m<sup>2</sup>  
 Área de Aterro: 0,02m<sup>2</sup>  
 Volume Acumulado: 3.465,68m<sup>3</sup>  
 Cota Projeto: 520,579m

PLATAFORMA ACABADA LADO ESQUERDO	PTO	1	2	3	4	5	6	33
	DIST	3,300	3,409	3,618	3,698	3,907	4,016	4,032
	COTA	520,496m	520,496m	520,373m	520,373m	520,496m	520,496m	520,480m

PLATAFORMA ACABADA LADO DIREITO	PTO	1	2	3	4	5	33
	DIST	3,300m	3,409m	3,618m	3,698m	3,907m	4,016m
	COTA	520,496m	520,496m	520,373m	520,373m	520,496m	520,496m



ALINHAMENTO LEOBERTO LEAL SC-408

Estaca: 1+003,12

Área de Corte: 9,09m<sup>2</sup>  
 Área de Aterro: 0,16m<sup>2</sup>  
 Volume Acumulado: 3.493,52m<sup>3</sup>  
 Cota Projeto: 520,880m

PLATAFORMA ACABADA LADO ESQUERDO	PTO	1	2	3	4	5	6	33
	DIST	3,300	3,409	3,618	3,698	3,907	4,016	4,157
	COTA	520,798m	520,798m	520,675m	520,675m	520,798m	520,798m	520,656m

PLATAFORMA ACABADA LADO DIREITO	PTO	1	2	3	4	5	33
	DIST	3,300m	3,409m	3,618m	3,698m	3,907m	4,016m
	COTA	520,798m	520,798m	520,675m	520,675m	520,798m	520,798m

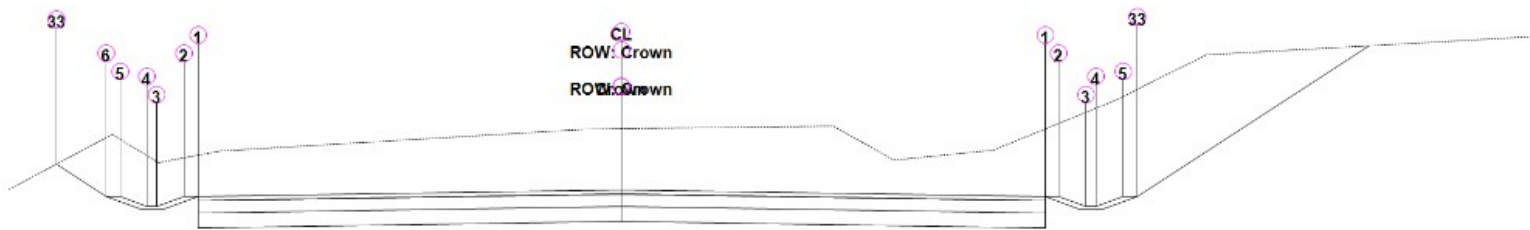

ALINHAMENTO LEOBERTO LEAL SC-408

Estaca: 1+011,99

Área de Corte: 9,62m<sup>2</sup>  
 Área de Aterro: 0,00m<sup>2</sup>  
 Volume Acumulado: 3.577,79m<sup>3</sup>  
 Cota Projeto: 521,737m

PLATAFORMA ACABADA LADO ESQUERDO	PTO	1	2	3	4	5	6	33
	DIST	3,300	3,409	3,618	3,698	3,907	4,016	4,404
	COTA	521,654m	521,654m	521,531m	521,531m	521,654m	521,654m	522,043m

PLATAFORMA ACABADA LADO DIREITO	PTO	1	2	3	4	5	33
	DIST	3,300m	3,409m	3,618m	3,698m	3,907m	4,016m
	COTA	521,654m	521,654m	521,531m	521,531m	521,654m	521,654m

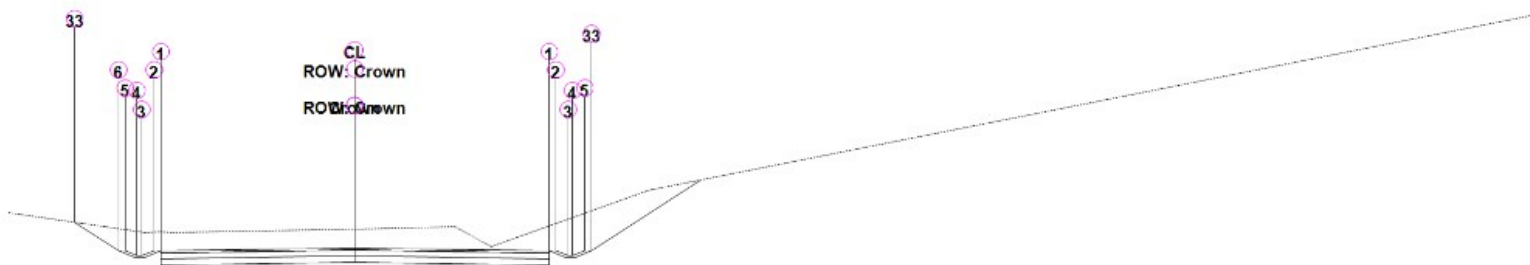

ALINHAMENTO LEOBERTO LEAL SC-408

Estaca: 1+020,00

Área de Corte: 8,05m<sup>2</sup>  
 Área de Aterro: 0,00m<sup>2</sup>  
 Volume Acumulado: 3.649,55m<sup>3</sup>  
 Cota Projeto: 522,511m

PLATAFORMA ACABADA LADO ESQUERDO	PTO	1	2	3	4	5	6	33
	DIST	3,300	3,409	3,618	3,698	3,907	4,016	4,767
	COTA	522,428m	522,428m	522,305m	522,305m	522,428m	522,428m	523,179m

PLATAFORMA ACABADA LADO DIREITO	PTO	1	2	3	4	5	33
	DIST	3,300m	3,409m	3,618m	3,698m	3,907m	4,016m
	COTA	522,428m	522,428m	522,305m	522,305m	522,428m	522,428m

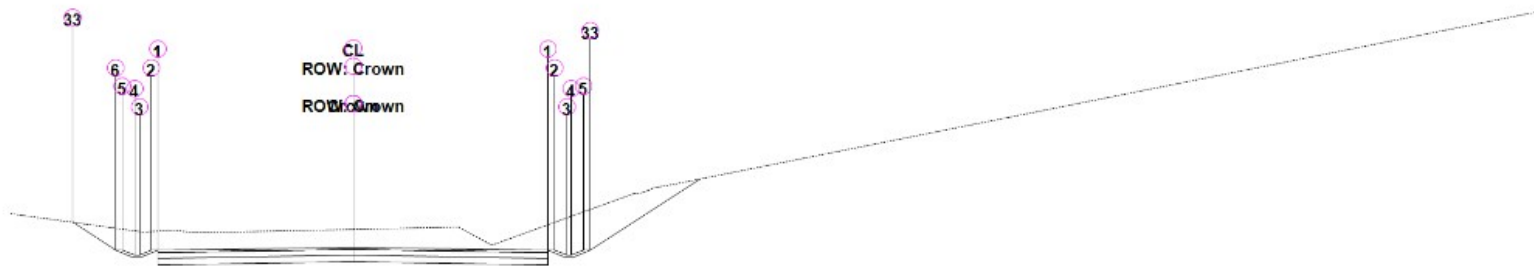

ALINHAMENTO LEOBERTO LEAL SC-408

Estaca: 1+020,86

Área de Corte: 7,97m<sup>2</sup>  
 Área de Aterro: 0,00m<sup>2</sup>  
 Volume Acumulado: 3.656,50m<sup>3</sup>  
 Cota Projeto: 522,594m

PLATAFORMA ACABADA LADO ESQUERDO	PTO	1	2	3	4	5	6	33
	DIST	3,300	3,409	3,618	3,698	3,907	4,016	4,747
	COTA	522,511m	522,511m	522,388m	522,388m	522,511m	522,511m	523,242m

PLATAFORMA ACABADA LADO DIREITO	PTO	1	2	3	4	5	33
	DIST	3,300m	3,409m	3,618m	3,698m	3,907m	4,016m
	COTA	522,511m	522,511m	522,388m	522,388m	522,511m	522,511m

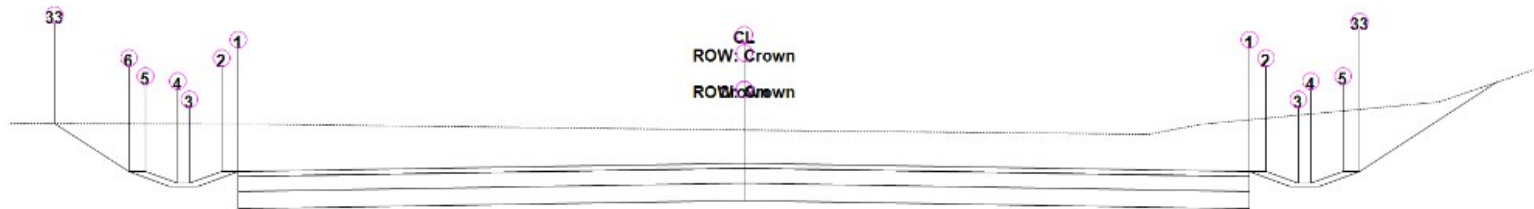

ALINHAMENTO LEOBERTO LEAL SC-408

Estaca: 1+040,00

Área de Corte: 6,32m<sup>2</sup>  
 Área de Aterro: 0,00m<sup>2</sup>  
 Volume Acumulado: 3.793,06m<sup>3</sup>  
 Cota Projeto: 524,443m

PLATAFORMA ACABADA LADO ESQUERDO	PTO	1	2	3	4	5	6	33
	DIST	3,300	3,409	3,618	3,698	3,907	4,016	4,500
	COTA	524,361m	524,361m	524,238m	524,238m	524,361m	524,361m	524,845m

PLATAFORMA ACABADA LADO DIREITO	PTO	1	2	3	4	5	33
	DIST	3,300m	3,409m	3,618m	3,698m	3,907m	4,016m
	COTA	524,361m	524,361m	524,238m	524,238m	524,361m	524,361m

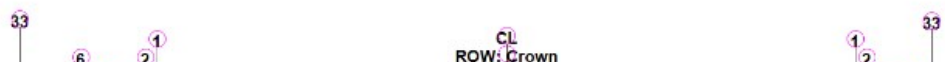

ALINHAMENTO LEOBERTO LEAL SC-408

Estaca: 1+046,04

Área de Corte: 6,52m<sup>2</sup>  
 Área de Aterro: 0,00m<sup>2</sup>  
 Volume Acumulado: 3.831,85m<sup>3</sup>  
 Cota Projeto: 525,027m

PLATAFORMA ACABADA LADO ESQUERDO	PTO	1	2	3	4	5	6	33
	DIST	3,300	3,409	3,618	3,698	3,907	4,016	4,599
	COTA	524,944m	524,944m	524,821m	524,821m	524,944m	524,944m	525,528m

PLATAFORMA ACABADA LADO DIREITO	PTO	1	2	3	4	5	33
	DIST	3,300m	3,409m	3,618m	3,698m	3,907m	4,016m
	COTA	524,944m	524,944m	524,821m	524,821m	524,944m	524,944m

ALINHAMENTO LEOBERTO LEAL SC-408

Estaca: 1+060,00

Área de Corte: 7,68m<sup>2</sup>  
 Área de Aterro: 0,00m<sup>2</sup>  
 Volume Acumulado: 3.930,98m<sup>3</sup>  
 Cota Projeto: 526,375m

PLATAFORMA ACABADA LADO ESQUERDO	PTO	1	2	3	4	5	6	33
	DIST	3,300	3,409	3,618	3,698	3,907	4,016	4,828
	COTA	526,293m	526,293m	526,170m	526,170m	526,293m	526,293m	527,105m

PLATAFORMA ACABADA LADO DIREITO	PTO	1	2	3	4	5	33
	DIST	3,300m	3,409m	3,618m	3,698m	3,907m	4,016m
	COTA	526,293m	526,293m	526,170m	526,170m	526,293m	526,293m

ALINHAMENTO LEOBERTO LEAL SC-408

Área de Corte: 9,50m<sup>2</sup>  
 Área de Aterro: 0,00m<sup>2</sup>  
 Volume Acumulado: 4.027,38m<sup>3</sup>  
 Cota Projeto: 527,461m

PLATAFORMA ACABADA LADO ESQUERDO	PTO	1	2	3	4	5	6	33
	DIST	3,300	3,409	3,618	3,698	3,907	4,016	5,025
	COTA	527,378m	527,378m	527,255m	527,255m	527,378m	527,378m	528,388m

PLATAFORMA ACABADA LADO DIREITO	PTO	1	2	3	4	5	33
	DIST	3,300m	3,409m	3,618m	3,698m	3,907m	4,016m
	COTA	527,378m	527,378m	527,255m	527,255m	527,378m	527,378m

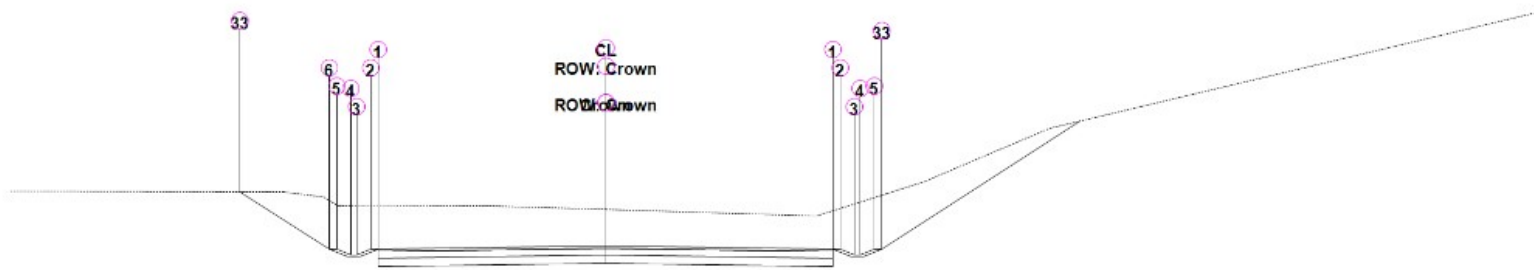

ALINHAMENTO LEOBERTO LEAL SC-408

Estaca: 1+080,00

Área de Corte: 12,28m<sup>2</sup>  
 Área de Aterro: 0,00m<sup>2</sup>  
 Volume Acumulado: 4.122,77m<sup>3</sup>  
 Cota Projeto: 528,309m

PLATAFORMA ACABADA LADO ESQUERDO	PTO	1	2	3	4	5	6	33
	DIST	3,300	3,409	3,618	3,698	3,907	4,016	5,307
	COTA	528,226m	528,226m	528,103m	528,103m	528,226m	528,226m	529,517m

PLATAFORMA ACABADA LADO DIREITO	PTO	1	2	3	4	5	33
	DIST	3,300m	3,409m	3,618m	3,698m	3,907m	4,016m
	COTA	528,226m	528,226m	528,103m	528,103m	528,226m	528,226m

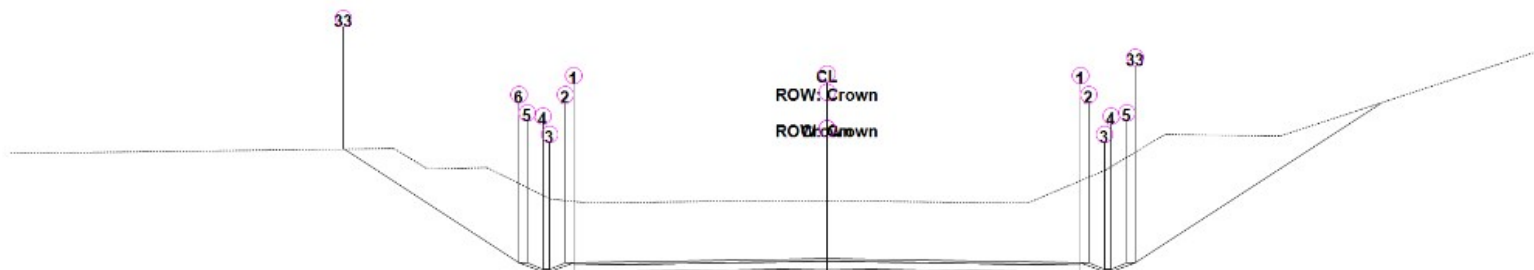

ALINHAMENTO LEOBERTO LEAL SC-408

Estaca: 1+100,00

Área de Corte: 18,35m<sup>2</sup>  
 Área de Aterro: 0,00m<sup>2</sup>  
 Volume Acumulado: 4.428,71m<sup>3</sup>  
 Cota Projeto: 530,243m

PLATAFORMA ACABADA LADO ESQUERDO	PTO	1	2	3	4	5	6	33
	DIST	3,300	3,409	3,618	3,698	3,907	4,016	6,300
	COTA	530,161m	530,161m	530,038m	530,038m	530,161m	530,161m	532,445m

PLATAFORMA ACABADA LADO DIREITO	PTO	1	2	3	4	5	33
	DIST	3,300m	3,409m	3,618m	3,698m	3,907m	4,016m
	COTA	530,161m	530,161m	530,038m	530,038m	530,161m	530,161m

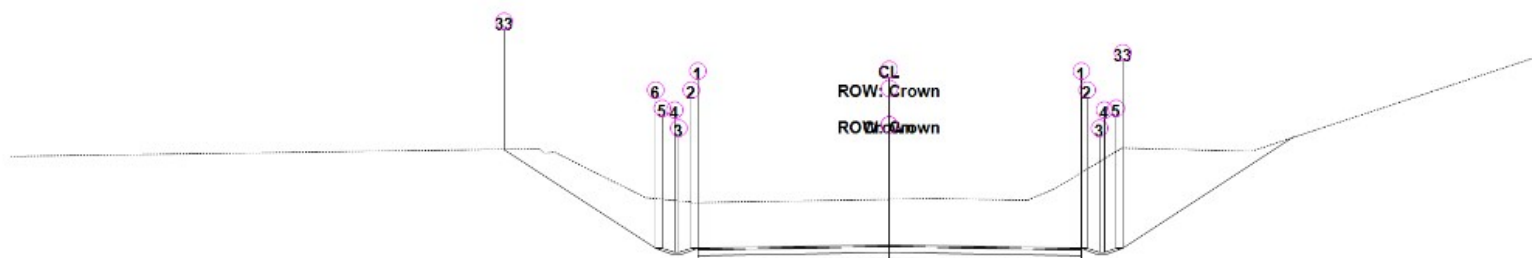

ALINHAMENTO LEOBERTO LEAL SC-408

Estaca: 1+104,61

Área de Corte: 19,15m<sup>2</sup>  
 Área de Aterro: 0,00m<sup>2</sup>  
 Volume Acumulado: 4.515,18m<sup>3</sup>  
 Cota Projeto: 530,689m

PLATAFORMA ACABADA LADO ESQUERDO	PTO	1	2	3	4	5	6	33
	DIST	3,300	3,409	3,618	3,698	3,907	4,016	6,625
	COTA	530,607m	530,607m	530,484m	530,484m	530,607m	530,607m	533,216m

PLATAFORMA ACABADA LADO DIREITO	PTO	1	2	3	4	5	33
	DIST	3,300m	3,409m	3,618m	3,698m	3,907m	4,016m
	COTA	530,607m	530,607m	530,484m	530,484m	530,607m	530,607m

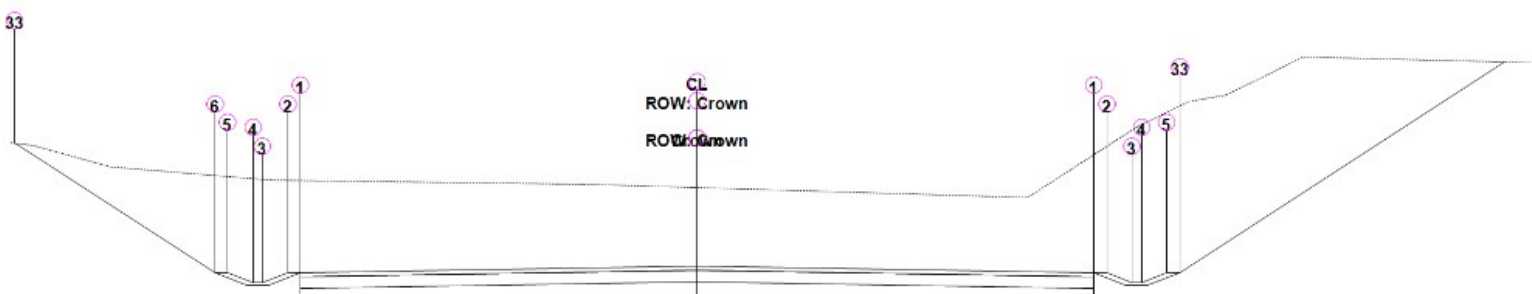

ALINHAMENTO LEOBERTO LEAL SC-408

Área de Corte: 16,24m<sup>2</sup>  
 Área de Aterro: 0,00m<sup>2</sup>  
 Volume Acumulado: 4.787,10m<sup>3</sup>  
 Cota Projeto: 532,179m

PLATAFORMA ACABADA LADO ESQUERDO	PTO	1	2	3	4	5	6	33
	DIST	3,300	3,409	3,618	3,698	3,907	4,016	5,679
	COTA	532,096m	532,096m	531,973m	531,973m	532,096m	532,096m	533,760m

PLATAFORMA ACABADA LADO DIREITO	PTO	1	2	3	4	5	33
	DIST	3,300m	3,409m	3,618m	3,698m	3,907m	4,016m
	COTA	532,096m	532,096m	531,973m	531,973m	532,096m	532,096m

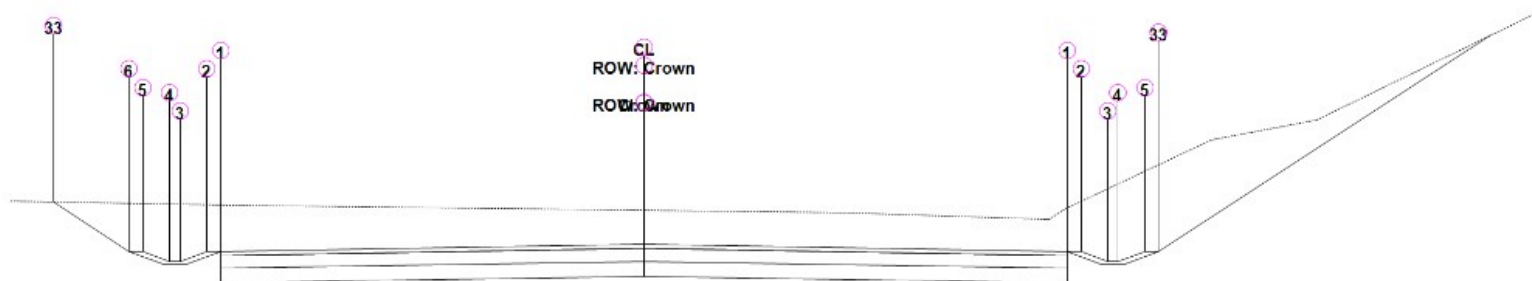

ALINHAMENTO LEOBERTO LEAL SC-408

Área de Corte: 7,85m<sup>2</sup>  
 Área de Aterro: 0,00m<sup>2</sup>  
 Volume Acumulado: 5.003,58m<sup>3</sup>  
 Cota Projeto: 533,921m

PLATAFORMA ACABADA LADO ESQUERDO	PTO	1	2	3	4	5	6	33
	DIST	3,300	3,409	3,618	3,698	3,907	4,016	4,609
	COTA	533,839m	533,839m	533,716m	533,716m	533,839m	533,839m	534,432m

PLATAFORMA ACABADA LADO DIREITO	PTO	1	2	3	4	5	33
	DIST	3,300m	3,409m	3,618m	3,698m	3,907m	4,016m
	COTA	533,839m	533,839m	533,716m	533,716m	533,839m	533,839m



ALINHAMENTO LEOBERTO LEAL SC-408

Estaca: 1+140,00

Área de Corte: 6,89m<sup>2</sup>  
 Área de Aterro: 0,00m<sup>2</sup>  
 Volume Acumulado: 5.018,25m<sup>3</sup>  
 Cota Projeto: 534,115m

PLATAFORMA ACABADA LADO ESQUERDO	PTO	1	2	3	4	5	6	33
	DIST	3,300	3,409	3,618	3,698	3,907	4,016	4,512
	COTA	534,033m	534,033m	533,910m	533,910m	534,033m	534,033m	534,529m

PLATAFORMA ACABADA LADO DIREITO	PTO	1	2	3	4	5	33
	DIST	3,300m	3,409m	3,618m	3,698m	3,907m	4,016m
	COTA	534,033m	534,033m	533,910m	533,910m	534,033m	534,033m

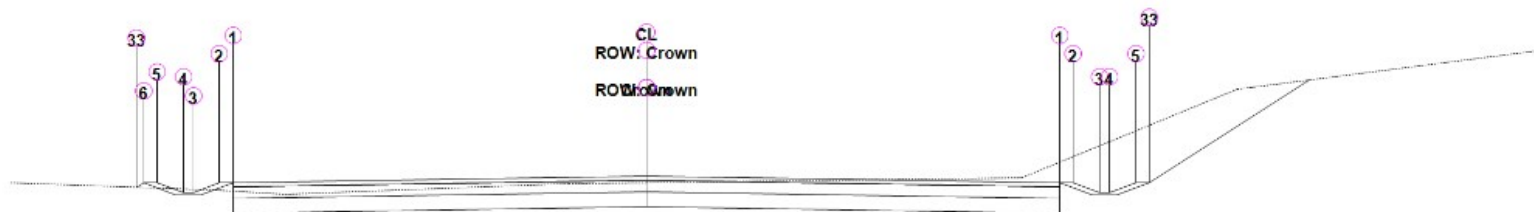

ALINHAMENTO LEOBERTO LEAL SC-408

Estaca: 1+153,80

Área de Corte: 3,11m<sup>2</sup>  
 Área de Aterro: 0,01m<sup>2</sup>  
 Volume Acumulado: 5.087,59m<sup>3</sup>  
 Cota Projeto: 535,452m

PLATAFORMA ACABADA LADO ESQUERDO	PTO	1	2	3	4	5	6	33
	DIST	3,300	3,409	3,618	3,698	3,907	4,016	4,073
	COTA	535,370m	535,370m	535,247m	535,247m	535,370m	535,370m	535,313m

PLATAFORMA ACABADA LADO DIREITO	PTO	1	2	3	4	5	33
	DIST	3,300m	3,409m	3,618m	3,698m	3,907m	4,016m
	COTA	535,370m	535,370m	535,247m	535,247m	535,370m	535,370m



ALINHAMENTO LEOBERTO LEAL SC-408

Estaca: 1+160,00



Área de Corte: 1,14m<sup>2</sup>  
 Área de Aterro: 0,16m<sup>2</sup>  
 Volume Acumulado: 5.100,40m<sup>3</sup>  
 Cota Projeto: 536,053m

PLATAFORMA ACABADA LADO ESQUERDO	PTO	1	2	3	4	5	6	33
	DIST	3,300	3,409	3,618	3,698	3,907	4,016	4,250
	COTA	535,971m	535,971m	535,848m	535,848m	535,971m	535,971m	535,737m

PLATAFORMA ACABADA LADO DIREITO	PTO	1	2	3	4	5	33
	DIST	3,300m	3,409m	3,618m	3,698m	3,907m	4,016m
	COTA	535,971m	535,971m	535,848m	535,848m	535,971m	535,971m

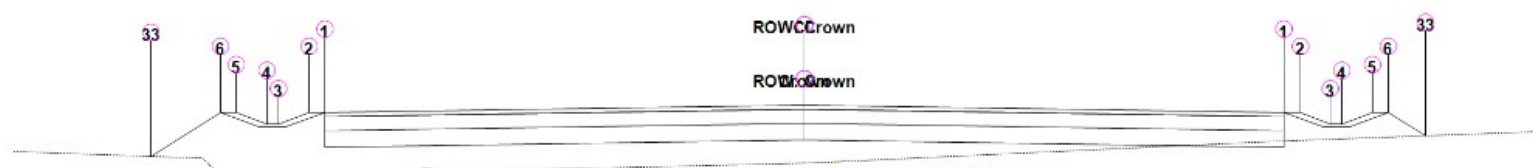

ALINHAMENTO LEOBERTO LEAL SC-408

Estaca: 1+169,61

Área de Corte: 0,02m<sup>2</sup>  
 Área de Aterro: 2,18m<sup>2</sup>  
 Volume Acumulado: 5.094,98m<sup>3</sup>  
 Cota Projeto: 536,984m

PLATAFORMA ACABADA LADO ESQUERDO	PTO	1	2	3	4	5	6	33
	DIST	3,300	3,409	3,618	3,698	3,907	4,016	4,493
	COTA	536,902m	536,902m	536,779m	536,779m	536,902m	536,902m	536,425m

PLATAFORMA ACABADA LADO DIREITO	PTO	1	2	3	4	5	6	33
	DIST	3,300m	3,409m	3,618m	3,698m	3,907m	4,016m	4,272m
	COTA	536,902m	536,902m	536,779m	536,779m	536,902m	536,902m	536,646m

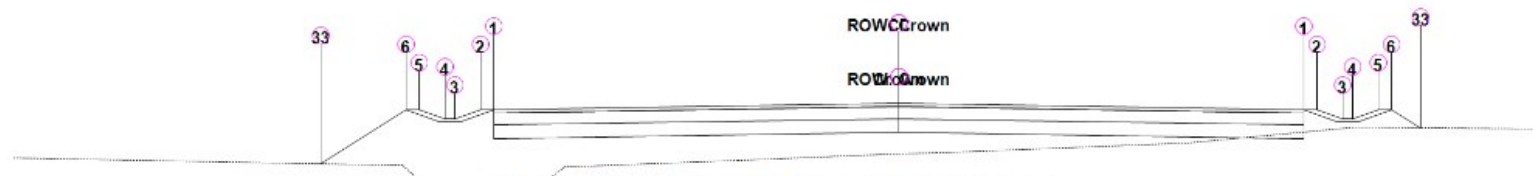

ALINHAMENTO LEOBERTO LEAL SC-408

Estaca: 1+176,70

Área de Corte: 0,02m<sup>2</sup>  
 Área de Aterro: 2,88m<sup>2</sup>  
 Volume Acumulado: 5.078,75m<sup>3</sup>  
 Cota Projeto: 537,672m

PLATAFORMA ACABADA LADO ESQUERDO	PTO	1	2	3	4	5	6	33
	DIST	3,300	3,409	3,618	3,698	3,907	4,016	4,712
	COTA	537,590m	537,590m	537,467m	537,467m	537,590m	537,590m	536,893m

PLATAFORMA ACABADA LADO DIREITO	PTO	1	2	3	4	5	6	33
	DIST	3,300m	3,409m	3,618m	3,698m	3,907m	4,016m	4,253m
	COTA	537,590m	537,590m	537,467m	537,467m	537,590m	537,590m	537,352m



ALINHAMENTO LEOBERTO LEAL SC-408

Estaca: 1+180,00

Área de Corte: 0,08m<sup>2</sup>  
 Área de Aterro: 2,56m<sup>2</sup>  
 Volume Acumulado: 5.070,75m<sup>3</sup>  
 Cota Projeto: 537,992m

PLATAFORMA ACABADA LADO ESQUERDO	PTO	1	2	3	4	5	6	33
	DIST	3,300	3,409	3,618	3,698	3,907	4,016	4,793
	COTA	537,909m	537,909m	537,786m	537,786m	537,909m	537,909m	537,133m

PLATAFORMA ACABADA LADO DIREITO	PTO	1	2	3	4	5	6	33
	DIST	3,300m	3,409m	3,618m	3,698m	3,907m	4,016m	4,095m
	COTA	537,909m	537,909m	537,786m	537,786m	537,909m	537,909m	537,830m



ALINHAMENTO LEOBERTO LEAL SC-408

Estaca: 1+183,80

Área de Corte: 0,06m<sup>2</sup>  
 Área de Aterro: 3,04m<sup>2</sup>  
 Volume Acumulado: 5.061,32m<sup>3</sup>  
 Cota Projeto: 538,360m

PLATAFORMA ACABADA LADO ESQUERDO	PTO	1	2	3	4	5	6	33
	DIST	3,300	3,409	3,618	3,698	3,907	4,016	4,880
	COTA	538,278m	538,278m	538,155m	538,155m	538,278m	538,278m	537,414m

PLATAFORMA ACABADA LADO DIREITO	PTO	1	2	3	4	5	6	33
	DIST	3,300m	3,409m	3,618m	3,698m	3,907m	4,016m	4,102m
	COTA	538,278m	538,278m	538,155m	538,155m	538,278m	538,278m	538,192m

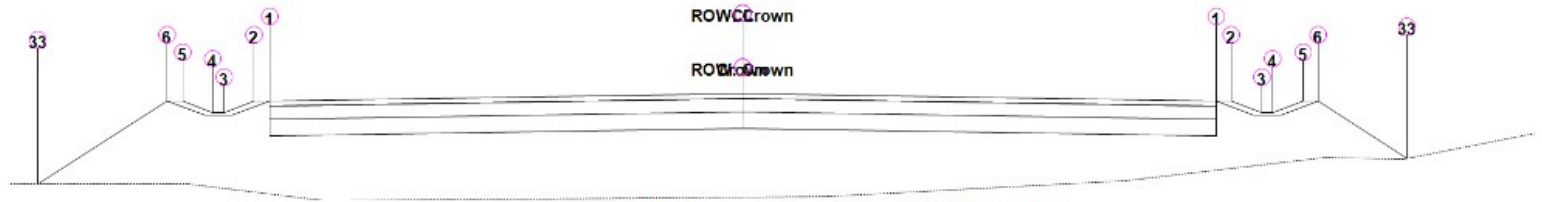

ALINHAMENTO LEOBERTO LEAL SC-408

Estaca: 1+200,00

Área de Corte: 0,00m<sup>2</sup>  
 Área de Aterro: 5,99m<sup>2</sup>  
 Volume Acumulado: 4.988,64m<sup>3</sup>  
 Cota Projeto: 539,932m

PLATAFORMA ACABADA LADO ESQUERDO	PTO	1	2	3	4	5	6	33
	DIST	3,300	3,409	3,618	3,698	3,907	4,016	4,915
	COTA	539,849m	539,849m	539,726m	539,726m	539,849m	539,849m	538,950m

PLATAFORMA ACABADA LADO DIREITO	PTO	1	2	3	4	5	6	33
	DIST	3,300m	3,409m	3,618m	3,698m	3,907m	4,016m	4,633m
	COTA	539,849m	539,849m	539,726m	539,726m	539,849m	539,849m	539,232m



ALINHAMENTO LEOBERTO LEAL SC-408

Estaca: 1+220,00

Área de Corte: 0,00m<sup>2</sup>  
 Área de Aterro: 9,65m<sup>2</sup>  
 Volume Acumulado: 4.832,19m<sup>3</sup>  
 Cota Projeto: 541,873m

PLATAFORMA ACABADA LADO ESQUERDO	PTO	1	2	3	4	5	6	33
	DIST	3,300	3,409	3,618	3,698	3,907	4,016	5,452
	COTA	541,791m	541,791m	541,668m	541,668m	541,791m	541,791m	540,354m

PLATAFORMA ACABADA LADO DIREITO	PTO	1	2	3	4	5	6	33
	DIST	3,300m	3,409m	3,618m	3,698m	3,907m	4,016m	5,051m
	COTA	541,791m	541,791m	541,668m	541,668m	541,791m	541,791m	540,755m

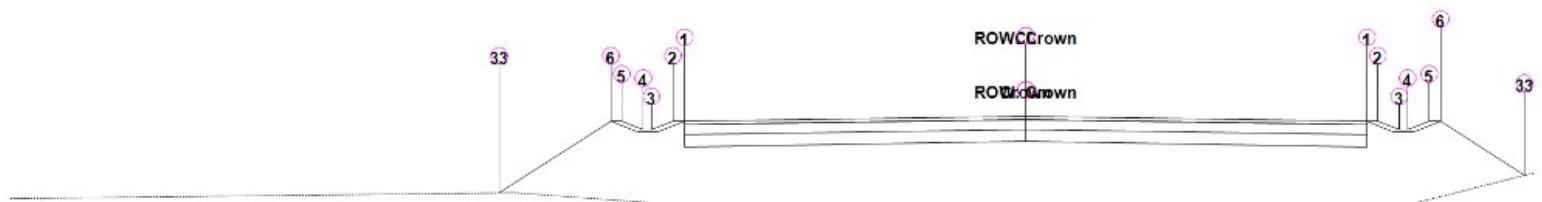

ALINHAMENTO LEOBERTO LEAL SC-408

Estaca: 1+240,00

Área de Corte: 0,00m<sup>2</sup>  
 Área de Aterro: 8,95m<sup>2</sup>  
 Volume Acumulado: 4.646,13m<sup>3</sup>  
 Cota Projeto: 543,815m

PLATAFORMA ACABADA LADO ESQUERDO	PTO	1	2	3	4	5	6	33
	DIST	3,300	3,409	3,618	3,698	3,907	4,016	5,093
	COTA	543,733m	543,733m	543,610m	543,610m	543,733m	543,733m	542,655m

PLATAFORMA ACABADA LADO DIREITO	PTO	1	2	3	4	5	6	33
	DIST	3,300m	3,409m	3,618m	3,698m	3,907m	4,016m	4,823m
	COTA	543,733m	543,733m	543,610m	543,610m	543,733m	543,733m	542,925m



ALINHAMENTO LEOBERTO LEAL SC-408

Estaca: 1+242,40

Área de Corte: 0,00m<sup>2</sup>  
 Área de Aterro: 8,54m<sup>2</sup>  
 Volume Acumulado: 4.625,11m<sup>3</sup>  
 Cota Projeto: 544,049m

PLATAFORMA ACABADA LADO ESQUERDO	PTO	1	2	3	4	5	6	33
	DIST	3,300	3,409	3,618	3,698	3,907	4,016	5,045
	COTA	543,966m	543,966m	543,843m	543,843m	543,966m	543,966m	542,937m

PLATAFORMA ACABADA LADO DIREITO	PTO	1	2	3	4	5	6	33
	DIST	3,300m	3,409m	3,618m	3,698m	3,907m	4,016m	4,677m
	COTA	543,966m	543,966m	543,843m	543,843m	543,966m	543,966m	543,305m

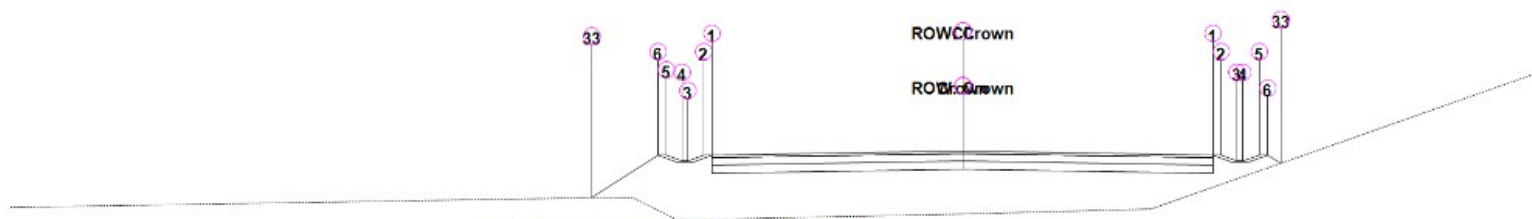

ALINHAMENTO LEOBERTO LEAL SC-408

Estaca: 1+253,33

Área de Corte: 0,00m<sup>2</sup>  
 Área de Aterro: 7,04m<sup>2</sup>  
 Volume Acumulado: 4.540,28m<sup>3</sup>  
 Cota Projeto: 545,110m

Cota Projeto: 545,110m

PLATAFORMA ACABADA LADO ESQUERDO	PTO	1	2	3	4	5	6	33
	DIST	3,300	3,409	3,618	3,698	3,907	4,016	4,880
	COTA	545,028m	545,028m	544,905m	544,905m	545,028m	545,028m	544,164m

PLATAFORMA ACABADA LADO DIREITO	PTO	1	2	3	4	5	6	33
	DIST	3,300m	3,409m	3,618m	3,698m	3,907m	4,016m	4,190m
	COTA	545,028m	545,028m	544,905m	544,905m	545,028m	545,028m	544,854m



ALINHAMENTO LEOBERTO LEAL SC-408

Estaca: 1+260,00

Área de Corte: 0,00m<sup>2</sup>  
 Área de Aterro: 6,29m<sup>2</sup>  
 Volume Acumulado: 4.496,13m<sup>3</sup>  
 Cota Projeto: 545,758m

PLATAFORMA ACABADA LADO ESQUERDO	PTO	1	2	3	4	5	6	33
	DIST	3,300	3,409	3,618	3,698	3,907	4,016	4,808
	COTA	545,676m	545,676m	545,553m	545,553m	545,676m	545,676m	544,884m

PLATAFORMA ACABADA LADO DIREITO	PTO	1	2	3	4	5	6	33
	DIST	3,300m	3,409m	3,618m	3,698m	3,907m	4,016m	4,107m
	COTA	545,676m	545,676m	545,553m	545,553m	545,676m	545,676m	545,585m

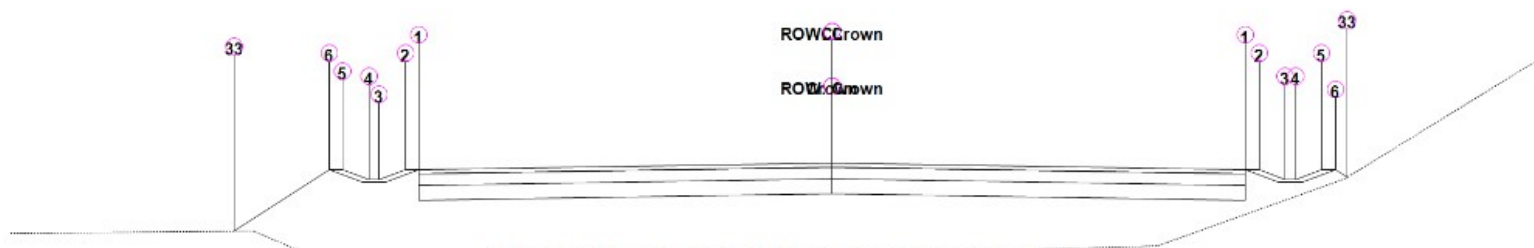

ALINHAMENTO LEOBERTO LEAL SC-408

Estaca: 1+264,26

Área de Corte: 0,00m<sup>2</sup>  
 Área de Aterro: 5,86m<sup>2</sup>  
 Volume Acumulado: 4.470,41m<sup>3</sup>  
 Cota Projeto: 546,172m

PLATAFORMA	PTO	1	2	3	4	5	6	33
------------	-----	---	---	---	---	---	---	----

ACABADA	DIST	3,300	3,409	3,618	3,698	3,907	4,016	4,776
LADO								
ESQUERDO	COTA	546,090m	546,090m	545,967m	545,967m	546,090m	546,090m	545,329m

PLATAFORMA	PTO	1	2	3	4	5	6	33
ACABADA								
LADO	DIST	3,300m	3,409m	3,618m	3,698m	3,907m	4,016m	4,112m
DIREITO	COTA	546,090m	546,090m	545,967m	545,967m	546,090m	546,090m	545,993m

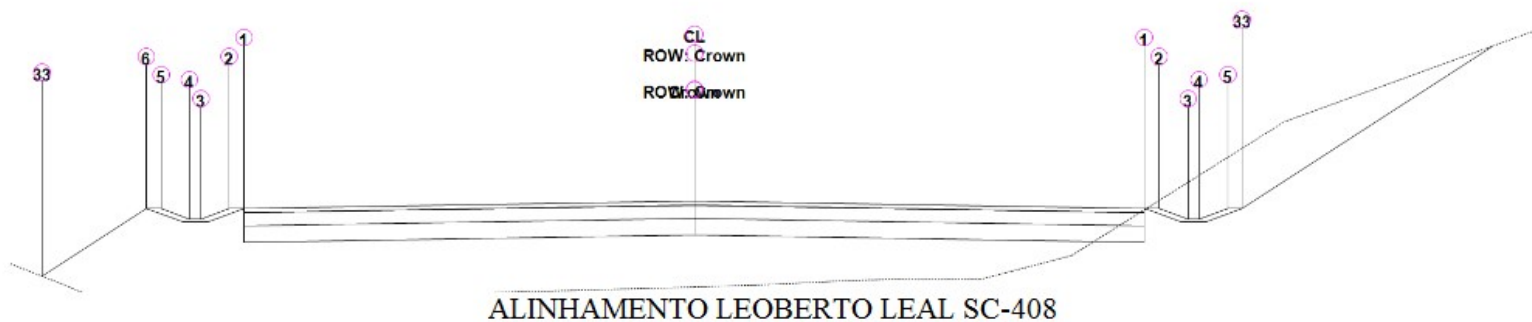

ALINHAMENTO LEOBERTO LEAL SC-408

Estaca: 1+271,58

Área de Corte: 1,10m<sup>2</sup>  
 Área de Aterro: 4,48m<sup>2</sup>  
 Volume Acumulado: 4.437,36m<sup>3</sup>  
 Cota Projeto: 546,884m

PLATAFORMA	PTO	1	2	3	4	5	6	33
ACABADA								
LADO	DIST	3,300	3,409	3,618	3,698	3,907	4,016	4,782
ESQUERDO	COTA	546,801m	546,801m	546,678m	546,678m	546,801m	546,801m	546,035m

PLATAFORMA	PTO	1	2	3	4	5	33
ACABADA							
LADO	DIST	3,300m	3,409m	3,618m	3,698m	3,907m	4,016m
DIREITO	COTA	546,801m	546,801m	546,678m	546,678m	546,801m	546,801m

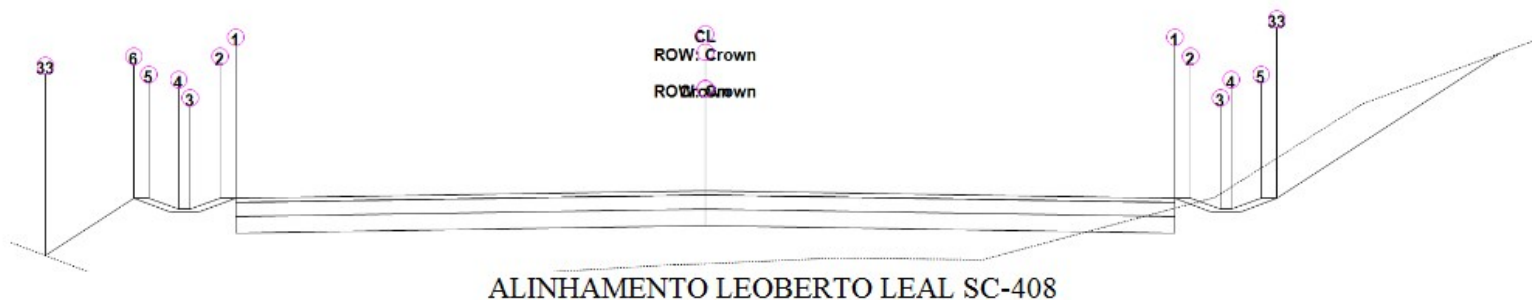

ALINHAMENTO LEOBERTO LEAL SC-408

Estaca: 1+278,90

Área de Corte: 0,70m<sup>2</sup>  
 Área de Aterro: 3,41m<sup>2</sup>  
 Volume Acumulado: 4.416,17m<sup>3</sup>  
 Cota Projeto: 547,595m

PLATAFORMA	PTO	1	2	3	4	5	6	33
------------	-----	---	---	---	---	---	---	----

ACABADA LADO ESQUERDO	DIST	3,300	3,409	3,618	3,698	3,907	4,016	4,637
	COTA	547,513m	547,513m	547,390m	547,390m	547,513m	547,513m	546,891m

PLATAFORMA ACABADA LADO DIREITO	PTO	1	2	3	4	5	33
	DIST	3,300m	3,409m	3,618m	3,698m	3,907m	4,016m
	COTA	547,513m	547,513m	547,390m	547,390m	547,513m	547,513m

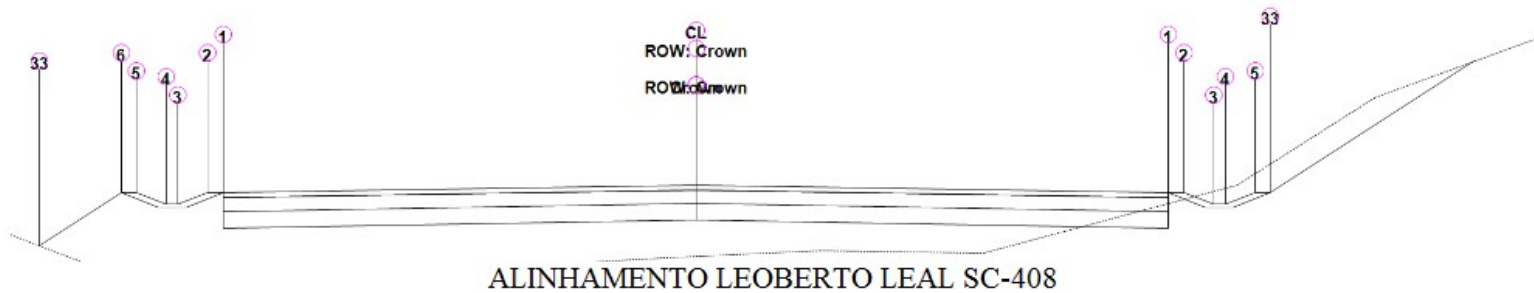

ALINHAMENTO LEOBERTO LEAL SC-408

Estaca: 1+280,00

Área de Corte: 0,52m<sup>2</sup>  
 Área de Aterro: 3,27m<sup>2</sup>  
 Volume Acumulado: 4.413,17m<sup>3</sup>  
 Cota Projeto: 547,702m

PLATAFORMA ACABADA LADO ESQUERDO	PTO	1	2	3	4	5	6	33
	DIST	3,300	3,409	3,618	3,698	3,907	4,016	4,586
	COTA	547,619m	547,619m	547,496m	547,496m	547,619m	547,619m	547,049m

PLATAFORMA ACABADA LADO DIREITO	PTO	1	2	3	4	5	33
	DIST	3,300m	3,409m	3,618m	3,698m	3,907m	4,016m
	COTA	547,619m	547,619m	547,496m	547,496m	547,619m	547,619m

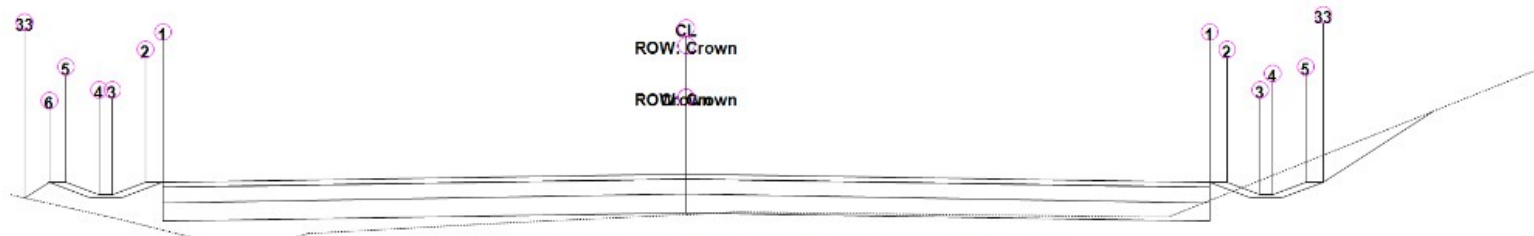

ALINHAMENTO LEOBERTO LEAL SC-408

Estaca: 1+300,00

Área de Corte: 0,30m<sup>2</sup>  
 Área de Aterro: 0,57m<sup>2</sup>  
 Volume Acumulado: 4.383,01m<sup>3</sup>  
 Cota Projeto: 549,645m

PLATAFORMA ACABADA LADO	PTO	1	2	3	4	5	6	33
	DIST	3,300	3,409	3,618	3,698	3,907	4,016	4,170

ESQUERDO	COTA	549,563m	549,563m	549,440m	549,440m	549,563m	549,563m	549,408m
----------	------	----------	----------	----------	----------	----------	----------	----------

PLATAFORMA ACABADA LADO DIREITO	PTO	1	2	3	4	5	33
	DIST	3,300m	3,409m	3,618m	3,698m	3,907m	4,016m
	COTA	549,563m	549,563m	549,440m	549,440m	549,563m	549,563m

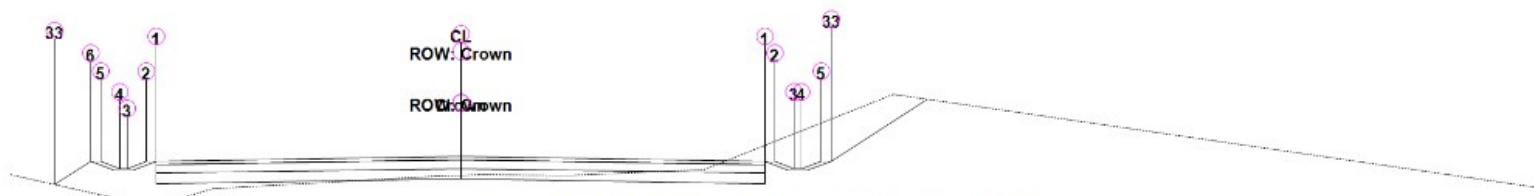

ALINHAMENTO LEOBERTO LEAL SC-408

Estaca: 1+304,28

Área de Corte: 1,56m<sup>2</sup>  
 Área de Aterro: 0,71m<sup>2</sup>  
 Volume Acumulado: 4.384,24m<sup>3</sup>  
 Cota Projeto: 550,061m

PLATAFORMA ACABADA LADO ESQUERDO	PTO	1	2	3	4	5	6	33
	DIST	3,300	3,409	3,618	3,698	3,907	4,016	4,406
	COTA	549,979m	549,979m	549,856m	549,856m	549,979m	549,979m	549,588m

PLATAFORMA ACABADA LADO DIREITO	PTO	1	2	3	4	5	33
	DIST	3,300m	3,409m	3,618m	3,698m	3,907m	4,016m
	COTA	549,979m	549,979m	549,856m	549,856m	549,979m	549,979m

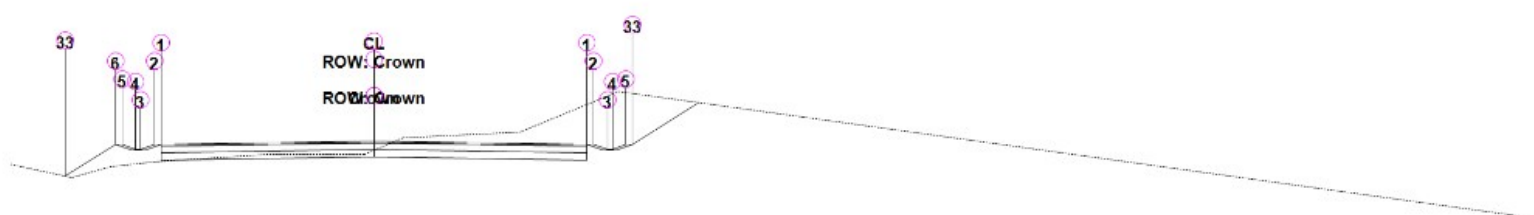

ALINHAMENTO LEOBERTO LEAL SC-408

Estaca: 1+313,28

Área de Corte: 3,88m<sup>2</sup>  
 Área de Aterro: 0,49m<sup>2</sup>  
 Volume Acumulado: 4.404,36m<sup>3</sup>  
 Cota Projeto: 550,935m

PLATAFORMA ACABADA LADO ESQUERDO	PTO	1	2	3	4	5	6	33
	DIST	3,300	3,409	3,618	3,698	3,907	4,016	4,789
	COTA	550,852m	550,852m	550,729m	550,729m	550,852m	550,852m	550,079m

PLATAFORMA ACABADA LADO DIREITO	PTO	1	2	3	4	5	33
	DIST	3,300m	3,409m	3,618m	3,698m	3,907m	4,016m
	COTA	550,852m	550,852m	550,729m	550,729m	550,852m	550,852m





ALINHAMENTO LEOBERTO LEAL SC-408

Estaca: 1+320,00

Área de Corte: 4,20m<sup>2</sup>  
 Área de Aterro: 0,41m<sup>2</sup>  
 Volume Acumulado: 4.429,58m<sup>3</sup>  
 Cota Projeto: 551,588m

PLATAFORMA ACABADA LADO ESQUERDO	PTO	1	2	3	4	5	6	33
	DIST	3,300	3,409	3,618	3,698	3,907	4,016	4,637
	COTA	551,506m	551,506m	551,383m	551,383m	551,506m	551,506m	550,884m

PLATAFORMA ACABADA LADO DIREITO	PTO	1	2	3	4	5	33
	DIST	3,300m	3,409m	3,618m	3,698m	3,907m	4,016m
	COTA	551,506m	551,506m	551,383m	551,383m	551,506m	551,506m



ALINHAMENTO LEOBERTO LEAL SC-408

Estaca: 1+322,27

Área de Corte: 4,06m<sup>2</sup>  
 Área de Aterro: 0,49m<sup>2</sup>  
 Volume Acumulado: 4.438,32m<sup>3</sup>  
 Cota Projeto: 551,809m

PLATAFORMA ACABADA LADO ESQUERDO	PTO	1	2	3	4	5	6	33
	DIST	3,300	3,409	3,618	3,698	3,907	4,016	4,655
	COTA	551,726m	551,726m	551,603m	551,603m	551,726m	551,726m	551,088m

PLATAFORMA ACABADA LADO DIREITO	PTO	1	2	3	4	5	33
	DIST	3,300m	3,409m	3,618m	3,698m	3,907m	4,016m
	COTA	551,726m	551,726m	551,603m	551,603m	551,726m	551,726m

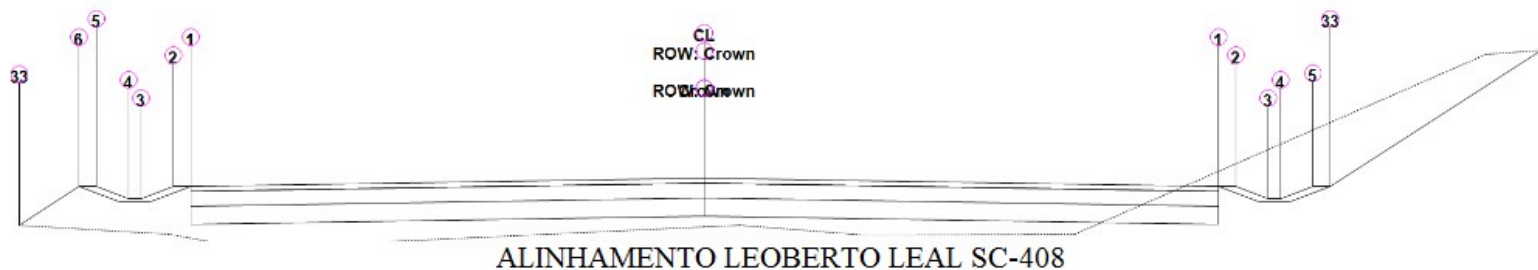

ALINHAMENTO LEOBERTO LEAL SC-408

Estaca: 1+334,32

Área de Corte: 1,10m<sup>2</sup>  
 Área de Aterro: 1,25m<sup>2</sup>  
 Volume Acumulado: 4.459,64m<sup>3</sup>  
 Cota Projeto: 552,980m

PLATAFORMA ACABADA LADO ESQUERDO	PTO	1	2	3	4	5	6	33
	DIST	3,300	3,409	3,618	3,698	3,907	4,016	4,402
	COTA	552,897m	552,897m	552,774m	552,774m	552,897m	552,897m	552,511m

PLATAFORMA ACABADA LADO DIREITO	PTO	1	2	3	4	5	33
	DIST	3,300m	3,409m	3,618m	3,698m	3,907m	4,016m
	COTA	552,897m	552,897m	552,774m	552,774m	552,897m	552,897m

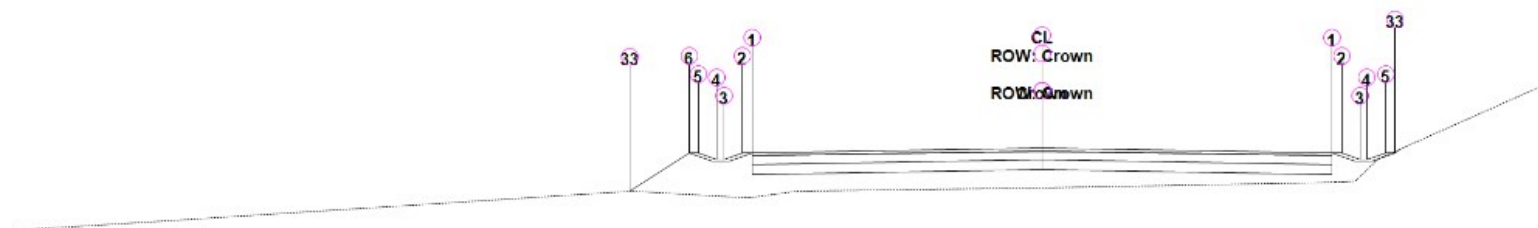

ALINHAMENTO LEOBERTO LEAL SC-408

Estaca: 1+340,00

Área de Corte: 0,00m<sup>2</sup>  
 Área de Aterro: 2,69m<sup>2</sup>  
 Volume Acumulado: 4.451,57m<sup>3</sup>  
 Cota Projeto: 553,531m

PLATAFORMA ACABADA LADO ESQUERDO	PTO	1	2	3	4	5	6	33
	DIST	3,300	3,409	3,618	3,698	3,907	4,016	4,695
	COTA	553,448m	553,448m	553,325m	553,325m	553,448m	553,448m	552,769m

PLATAFORMA ACABADA LADO DIREITO	PTO	1	2	3	4	5	33
	DIST	3,300m	3,409m	3,618m	3,698m	3,907m	4,016m
	COTA	553,448m	553,448m	553,325m	553,325m	553,448m	553,448m



ALINHAMENTO LEOBERTO LEAL SC-408

Estaca: 1+346,37

Área de Corte: 0,00m<sup>2</sup>  
 Área de Aterro: 2,42m<sup>2</sup>  
 Volume Acumulado: 4.435,32m<sup>3</sup>  
 Cota Projeto: 554,079m

PLATAFORMA ACABADA LADO ESQUERDO	PTO	1	2	3	4	5	6	33
	DIST	3,300	3,409	3,618	3,698	3,907	4,016	5,006
	COTA	553,996m	553,996m	553,873m	553,873m	553,996m	553,996m	553,006m

PLATAFORMA ACABADA LADO DIREITO	PTO	1	2	3	4	5	6	33
	DIST	3,300m	3,409m	3,618m	3,698m	3,907m	4,016m	4,109m
	COTA	553,996m	553,996m	553,873m	553,873m	553,996m	553,996m	553,902m

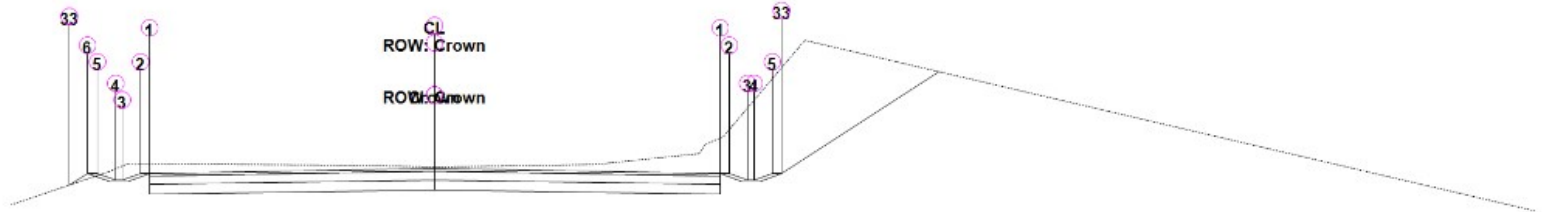

ALINHAMENTO LEOBERTO LEAL SC-408

Estaca: 1+360,00

Área de Corte: 6,66m<sup>2</sup>  
 Área de Aterro: 0,02m<sup>2</sup>  
 Volume Acumulado: 4.463,94m<sup>3</sup>  
 Cota Projeto: 554,861m

PLATAFORMA ACABADA LADO ESQUERDO	PTO	1	2	3	4	5	6	33
	DIST	3,300	3,409	3,618	3,698	3,907	4,016	4,233
	COTA	554,778m	554,778m	554,655m	554,655m	554,778m	554,778m	554,562m

PLATAFORMA ACABADA LADO DIREITO	PTO	1	2	3	4	5	33
	DIST	3,300m	3,409m	3,618m	3,698m	3,907m	4,016m
	COTA	554,778m	554,778m	554,655m	554,655m	554,778m	554,778m

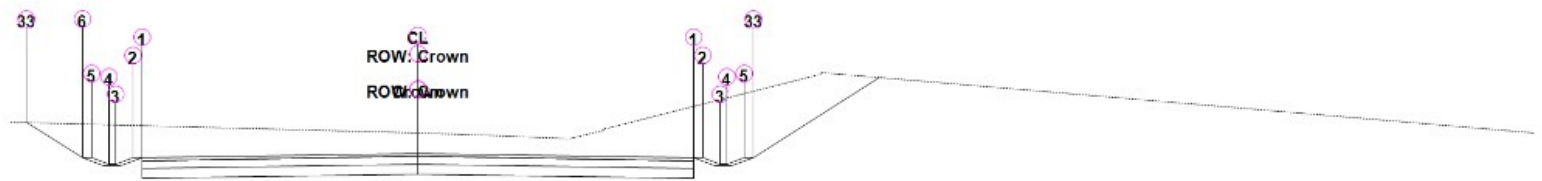

ALINHAMENTO LEOBERTO LEAL SC-408

Estaca: 1+378,06

Área de Corte: 8,45m<sup>2</sup>  
 Área de Aterro: 0,00m<sup>2</sup>  
 Volume Acumulado: 4.600,30m<sup>3</sup>  
 Cota Projeto: 555,080m

PLATAFORMA ACABADA LADO ESQUERDO	PTO	1	2	3	4	5	6	33
	DIST	3,300	3,409	3,618	3,698	3,907	4,016	4,685
	COTA	554,998m	554,998m	554,875m	554,875m	554,998m	554,998m	555,667m

PLATAFORMA ACABADA LADO DIREITO	PTO	1	2	3	4	5	33
	DIST	3,300m	3,409m	3,618m	3,698m	3,907m	4,016m
	COTA	554,998m	554,998m	554,875m	554,875m	554,998m	554,998m

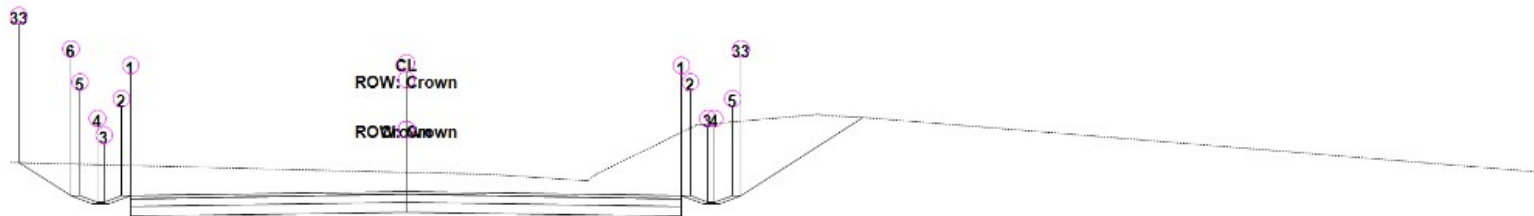

ALINHAMENTO LEOBERTO LEAL SC-408

Estaca: 1+380,00

Área de Corte: 8,31m<sup>2</sup>  
 Área de Aterro: 0,00m<sup>2</sup>  
 Volume Acumulado: 4.615,86m<sup>3</sup>  
 Cota Projeto: 555,048m

PLATAFORMA ACABADA LADO ESQUERDO	PTO	1	2	3	4	5	6	33
	DIST	3,300	3,409	3,618	3,698	3,907	4,016	4,640
	COTA	554,966m	554,966m	554,843m	554,843m	554,966m	554,966m	555,590m

PLATAFORMA ACABADA LADO DIREITO	PTO	1	2	3	4	5	33
	DIST	3,300m	3,409m	3,618m	3,698m	3,907m	4,016m
	COTA	554,966m	554,966m	554,843m	554,843m	554,966m	554,966m

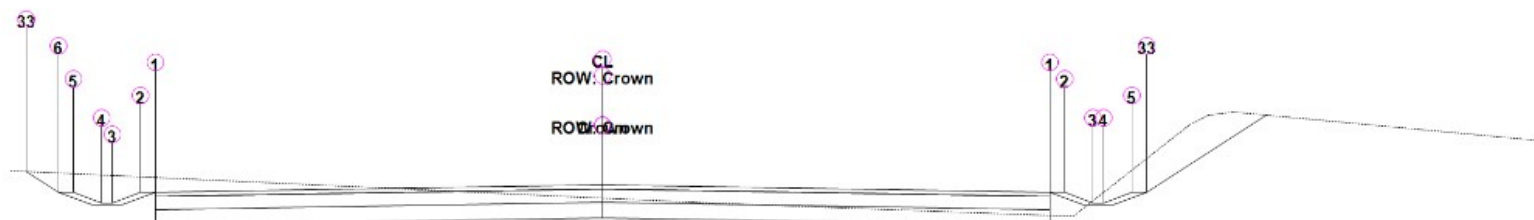

ALINHAMENTO LEOBERTO LEAL SC-408

Estaca: 1+391,11

Área de Corte: 2,46m<sup>2</sup>  
 Área de Aterro: 0,05m<sup>2</sup>

Área de Aterro: 0,09m<sup>2</sup>  
 Volume Acumulado: 4.674,42m<sup>3</sup>  
 Cota Projeto: 554,658m

PLATAFORMA ACABADA LADO ESQUERDO	PTO	1	2	3	4	5	6	33
	DIST	3,300	3,409	3,618	3,698	3,907	4,016	4,255
	COTA	554,576m	554,576m	554,453m	554,453m	554,576m	554,576m	554,815m

PLATAFORMA ACABADA LADO DIREITO	PTO	1	2	3	4	5	33
	DIST	3,300m	3,409m	3,618m	3,698m	3,907m	4,016m
	COTA	554,576m	554,576m	554,453m	554,453m	554,576m	554,576m

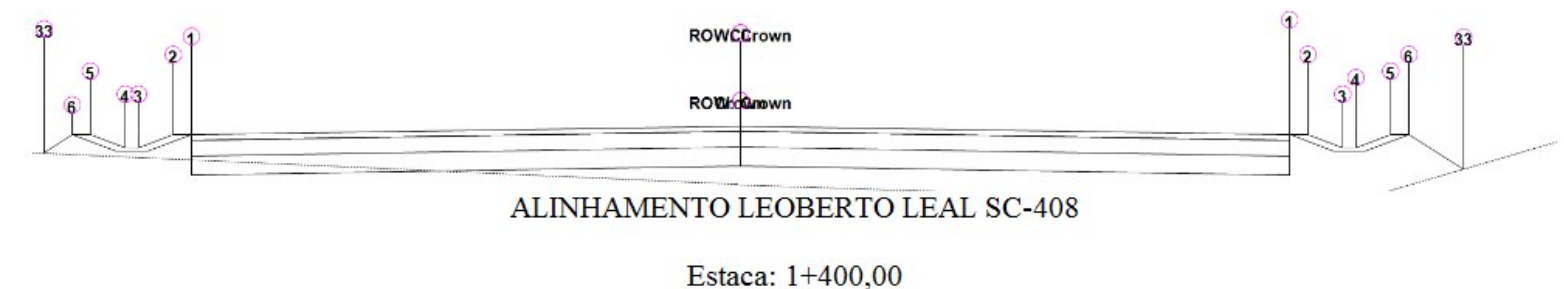

Área de Corte: 0,11m<sup>2</sup>  
 Área de Aterro: 1,40m<sup>2</sup>  
 Volume Acumulado: 4.680,00m<sup>3</sup>  
 Cota Projeto: 554,093m

PLATAFORMA ACABADA LADO ESQUERDO	PTO	1	2	3	4	5	6	33
	DIST	3,300	3,409	3,618	3,698	3,907	4,016	4,187
	COTA	554,010m	554,010m	553,887m	553,887m	554,010m	554,010m	553,839m

PLATAFORMA ACABADA LADO DIREITO	PTO	1	2	3	4	5	6	33
	DIST	3,300m	3,409m	3,618m	3,698m	3,907m	4,016m	4,341m
	COTA	554,010m	554,010m	553,887m	553,887m	554,010m	554,010m	553,685m



Área de Corte: 0,00m<sup>2</sup>  
 Área de Aterro: 2,33m<sup>2</sup>  
 Volume Acumulado: 4.672,87m<sup>3</sup>  
 Cota Projeto: 553,750m

PLATAFORMA ACABADA LADO ESQUERDO	PTO	1	2	3	4	5	6	33
	DIST	3,300	3,409	3,618	3,698	3,907	4,016	4,279
	COTA	553,668m	553,668m	553,545m	553,545m	553,668m	553,668m	553,405m

PLATAFORMA ACABADA LADO DIREITO	PTO	1	2	3	4	5	6	33
	DIST	3,300m	3,409m	3,618m	3,698m	3,907m	4,016m	4,595m
	COTA	553,668m	553,668m	553,545m	553,545m	553,668m	553,668m	553,088m

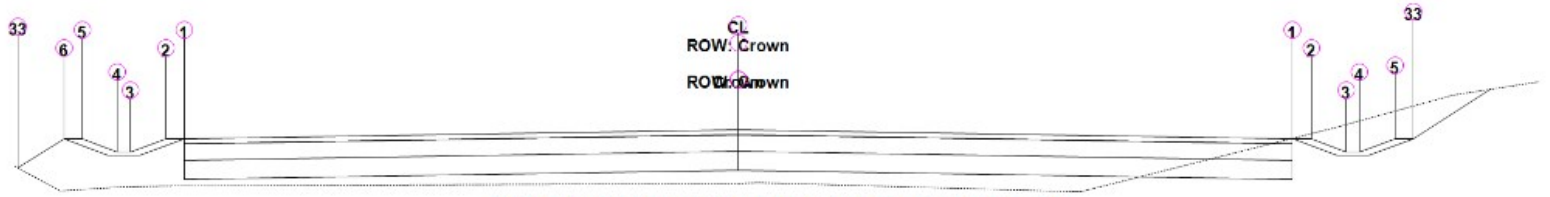

ALINHAMENTO LEOBERTO LEAL SC-408

Estaca: 1+420,00

Área de Corte: 0,43m<sup>2</sup>  
 Área de Aterro: 0,91m<sup>2</sup>  
 Volume Acumulado: 4.650,60m<sup>3</sup>  
 Cota Projeto: 552,252m

PLATAFORMA ACABADA LADO ESQUERDO	PTO	1	2	3	4	5	6	33
	DIST	3,300	3,409	3,618	3,698	3,907	4,016	4,291
	COTA	552,170m	552,170m	552,047m	552,047m	552,170m	552,170m	551,895m

PLATAFORMA ACABADA LADO DIREITO	PTO	1	2	3	4	5	33
	DIST	3,300m	3,409m	3,618m	3,698m	3,907m	4,016m
	COTA	552,170m	552,170m	552,047m	552,047m	552,170m	552,170m

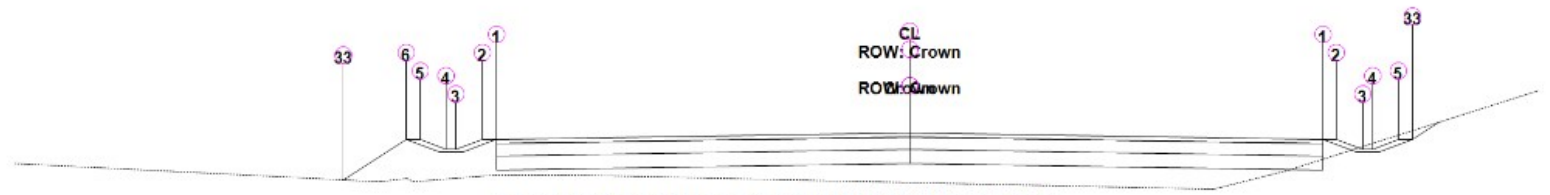

ALINHAMENTO LEOBERTO LEAL SC-408

Estaca: 1+424,57

Área de Corte: 0,08m<sup>2</sup>  
 Área de Aterro: 1,56m<sup>2</sup>  
 Volume Acumulado: 4.646,01m<sup>3</sup>  
 Cota Projeto: 551,818m

PLATAFORMA ACABADA LADO ESQUERDO	PTO	1	2	3	4	5	6	33
	DIST	3,300	3,409	3,618	3,698	3,907	4,016	4,518
	COTA	551,735m	551,735m	551,612m	551,612m	551,735m	551,735m	551,233m

PLATAFORMA ACABADA LADO DIREITO	PTO	1	2	3	4	5	33
	DIST	3,300m	3,409m	3,618m	3,698m	3,907m	4,016m
	COTA	551,735m	551,735m	551,612m	551,612m	551,735m	551,735m

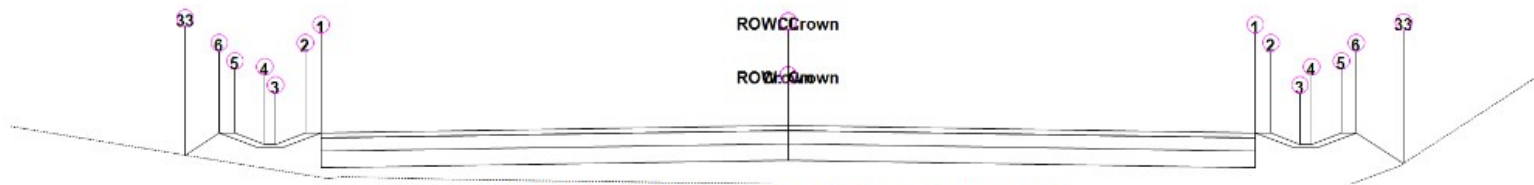

ALINHAMENTO LEOBERTO LEAL SC-408

Estaca: 1+440,00

Área de Corte: 0,00m<sup>2</sup>  
 Área de Aterro: 2,23m<sup>2</sup>  
 Volume Acumulado: 4.617,37m<sup>3</sup>  
 Cota Projeto: 550,354m

PLATAFORMA ACABADA LADO ESQUERDO	PTO	1	2	3	4	5	6	33
	DIST	3,300	3,409	3,618	3,698	3,907	4,016	4,257
	COTA	550,272m	550,272m	550,149m	550,149m	550,272m	550,272m	550,031m

PLATAFORMA ACABADA LADO DIREITO	PTO	1	2	3	4	5	6	33
	DIST	3,300m	3,409m	3,618m	3,698m	3,907m	4,016m	4,350m
	COTA	550,272m	550,272m	550,149m	550,149m	550,272m	550,272m	549,938m

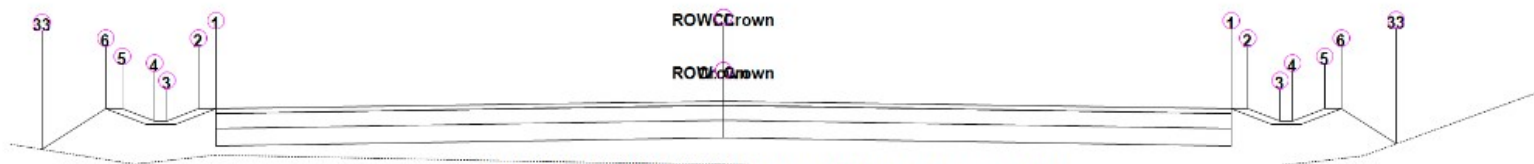

ALINHAMENTO LEOBERTO LEAL SC-408

Estaca: 1+444,98

Área de Corte: 0,00m<sup>2</sup>  
 Área de Aterro: 2,36m<sup>2</sup>  
 Volume Acumulado: 4.606,00m<sup>3</sup>  
 Cota Projeto: 549,883m

PLATAFORMA ACABADA LADO ESQUERDO	PTO	1	2	3	4	5	6	33
	DIST	3,300	3,409	3,618	3,698	3,907	4,016	4,429
	COTA	549,801m	549,801m	549,678m	549,678m	549,801m	549,801m	549,388m

PLATAFORMA ACABADA LADO DIREITO	PTO	1	2	3	4	5	6	33
	DIST	3,300m	3,409m	3,618m	3,698m	3,907m	4,016m	4,373m
	COTA	549,801m	549,801m	549,678m	549,678m	549,801m	549,801m	549,444m

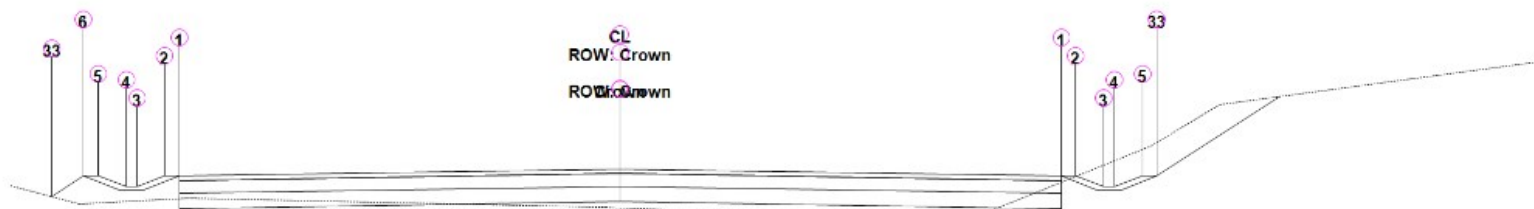

ALINHAMENTO LEOBERTO LEAL SC-408

Estaca: 1+460,00

Área de Corte: 0,65m<sup>2</sup>  
 Área de Aterro: 0,52m<sup>2</sup>  
 Volume Acumulado: 4.589,18m<sup>3</sup>  
 Cota Projeto: 548,464m

PLATAFORMA ACABADA LADO ESQUERDO	PTO	1	2	3	4	5	6	33
	DIST	3,300	3,409	3,618	3,698	3,907	4,016	4,256
	COTA	548,382m	548,382m	548,259m	548,259m	548,382m	548,382m	548,141m

PLATAFORMA ACABADA LADO DIREITO	PTO	1	2	3	4	5	33
	DIST	3,300m	3,409m	3,618m	3,698m	3,907m	4,016m
	COTA	548,382m	548,382m	548,259m	548,259m	548,382m	548,382m



ALINHAMENTO LEOBERTO LEAL SC-408

Estaca: 1+480,00

Área de Corte: 2,71m<sup>2</sup>  
 Área de Aterro: 0,03m<sup>2</sup>  
 Volume Acumulado: 4.617,02m<sup>3</sup>  
 Cota Projeto: 546,583m

PLATAFORMA ACABADA LADO ESQUERDO	PTO	1	2	3	4	5	6	33
	DIST	3,300	3,409	3,618	3,698	3,907	4,016	4,124
	COTA	546,500m	546,500m	546,377m	546,377m	546,500m	546,500m	546,392m

PLATAFORMA ACABADA LADO DIREITO	PTO	1	2	3	4	5	33
	DIST	3,300m	3,409m	3,618m	3,698m	3,907m	4,016m
	COTA	546,500m	546,500m	546,377m	546,377m	546,500m	546,500m

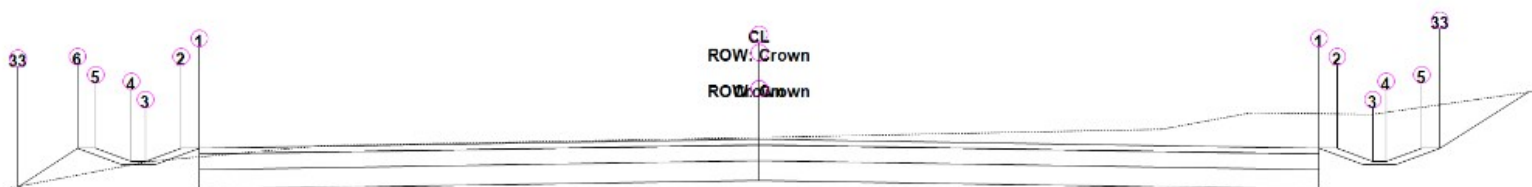

ALINHAMENTO LEOBERTO LEAL SC-408

Estaca: 1+482,44

Área de Corte: 3,38m<sup>2</sup>  
 Área de Aterro: 0,09m<sup>2</sup>  
 Volume Acumulado: 4.624,33m<sup>3</sup>



Cota Projeto: 546,353m

PLATAFORMA ACABADA LADO ESQUERDO	PTO	1	2	3	4	5	6	33
	DIST	3,300	3,409	3,618	3,698	3,907	4,016	4,370
	COTA	546,271m	546,271m	546,148m	546,148m	546,271m	546,271m	545,917m

PLATAFORMA ACABADA LADO DIREITO	PTO	1	2	3	4	5	33
	DIST	3,300m	3,409m	3,618m	3,698m	3,907m	4,016m
	COTA	546,271m	546,271m	546,148m	546,148m	546,271m	546,271m

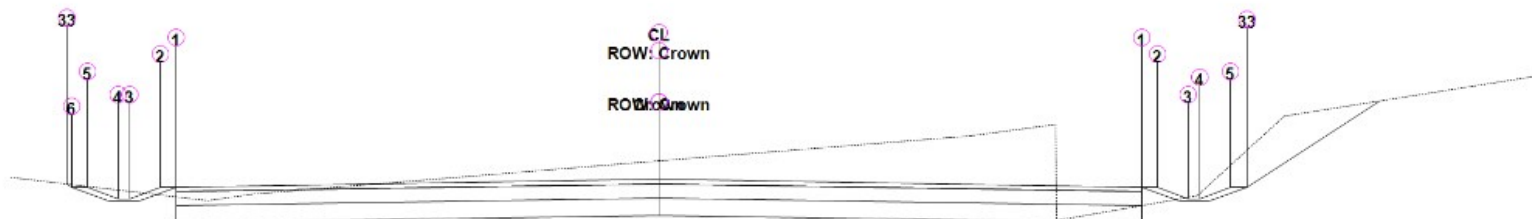

ALINHAMENTO LEOBERTO LEAL SC-408

Estaca: 1+500,00

Área de Corte: 3,92m<sup>2</sup>

Área de Aterro: 0,03m<sup>2</sup>

Volume Acumulado: 4.687,08m<sup>3</sup>

Cota Projeto: 544,709m

PLATAFORMA ACABADA LADO ESQUERDO	PTO	1	2	3	4	5	6	33
	DIST	3,300	3,409	3,618	3,698	3,907	4,016	4,050
	COTA	544,627m	544,627m	544,504m	544,504m	544,627m	544,627m	544,661m

PLATAFORMA ACABADA LADO DIREITO	PTO	1	2	3	4	5	33
	DIST	3,300m	3,409m	3,618m	3,698m	3,907m	4,016m
	COTA	544,627m	544,627m	544,504m	544,504m	544,627m	544,627m

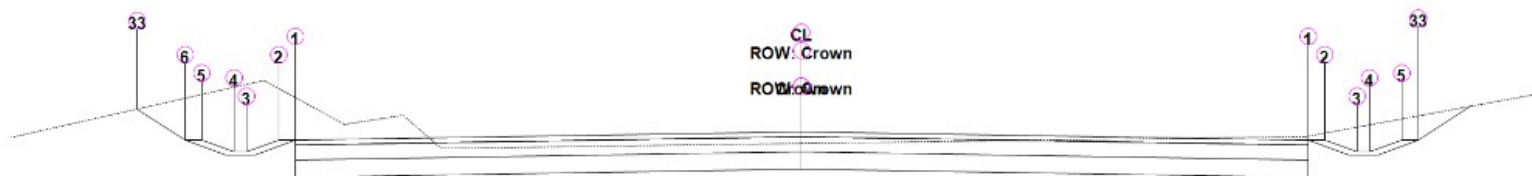

ALINHAMENTO LEOBERTO LEAL SC-408

Estaca: 1+519,91

Área de Corte: 2,98m<sup>2</sup>

Área de Aterro: 0,00m<sup>2</sup>

Volume Acumulado: 4.755,38m<sup>3</sup>

Cota Projeto: 542,852m

PLATAFORMA ACABADA LADO ESQUERDO	PTO	1	2	3	4	5	6	33
	DIST	3,300	3,409	3,618	3,698	3,907	4,016	4,328
	COTA	542,769m	542,769m	542,646m	542,646m	542,769m	542,769m	543,082m

PLATAFORMA ACABADA LADO DIREITO	PTO	1	2	3	4	5	33
	DIST	3,300m	3,409m	3,618m	3,698m	3,907m	4,016m
	COTA	542,769m	542,769m	542,646m	542,646m	542,769m	542,769m

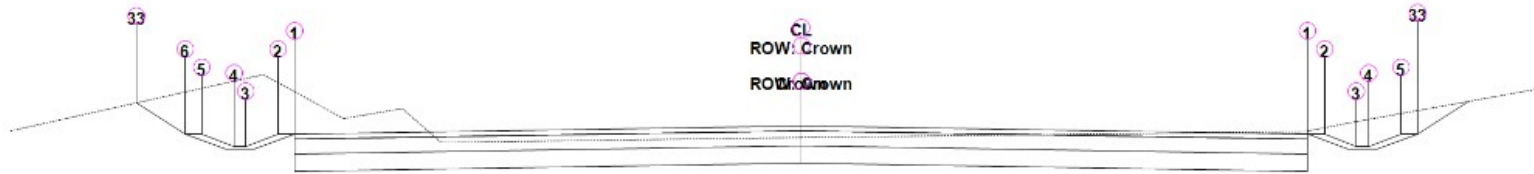

ALINHAMENTO LEOBERTO LEAL SC-408

Estaca: 1+520,00

Área de Corte: 2,99m<sup>2</sup>  
 Área de Aterro: 0,00m<sup>2</sup>  
 Volume Acumulado: 4.755,61m<sup>3</sup>  
 Cota Projeto: 542,844m

PLATAFORMA ACABADA LADO ESQUERDO	PTO	1	2	3	4	5	6	33
	DIST	3,300	3,409	3,618	3,698	3,907	4,016	4,334
	COTA	542,761m	542,761m	542,638m	542,638m	542,761m	542,761m	543,079m

PLATAFORMA ACABADA LADO DIREITO	PTO	1	2	3	4	5	33
	DIST	3,300m	3,409m	3,618m	3,698m	3,907m	4,016m
	COTA	542,761m	542,761m	542,638m	542,638m	542,761m	542,761m

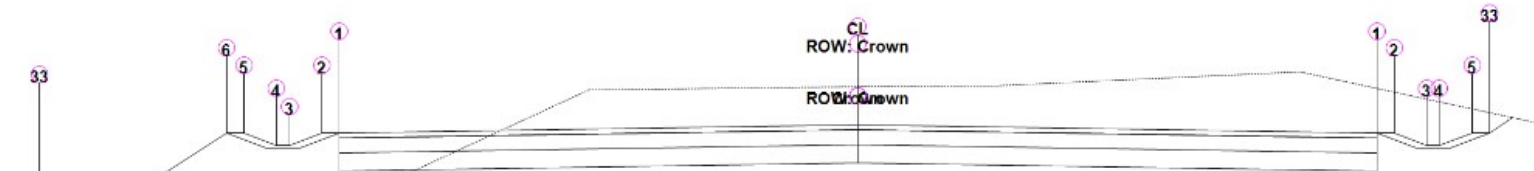

ALINHAMENTO LEOBERTO LEAL SC-408

Estaca: 1+540,00

Área de Corte: 4,85m<sup>2</sup>  
 Área de Aterro: 1,39m<sup>2</sup>  
 Volume Acumulado: 4.820,73m<sup>3</sup>  
 Cota Projeto: 540,987m

PLATAFORMA ACABADA LADO ESQUERDO	PTO	1	2	3	4	5	6	33
	DIST	3,300	3,409	3,618	3,698	3,907	4,016	5,207
	COTA	540,904m	540,904m	540,781m	540,781m	540,904m	540,904m	539,713m

PLATAFORMA ACABADA LADO DIREITO	PTO	1	2	3	4	5	33
	DIST	3,300m	3,409m	3,618m	3,698m	3,907m	4,016m
	COTA	540,904m	540,904m	540,781m	540,781m	540,904m	540,904m

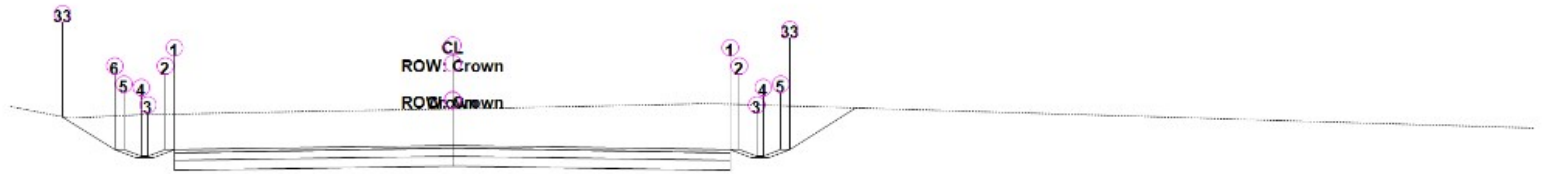

ALINHAMENTO LEOBERTO LEAL SC-408

Estaca: 1+554,96

Área de Corte: 9,00m<sup>2</sup>  
 Área de Aterro: 0,00m<sup>2</sup>  
 Volume Acumulado: 4.914,58m<sup>3</sup>  
 Cota Projeto: 539,603m

PLATAFORMA ACABADA LADO ESQUERDO	PTO	1	2	3	4	5	6	33
	DIST	3,300	3,409	3,618	3,698	3,907	4,016	4,629
	COTA	539,520m	539,520m	539,397m	539,397m	539,520m	539,520m	540,134m

PLATAFORMA ACABADA LADO DIREITO	PTO	1	2	3	4	5	33
	DIST	3,300m	3,409m	3,618m	3,698m	3,907m	4,016m
	COTA	539,520m	539,520m	539,397m	539,397m	539,520m	539,520m

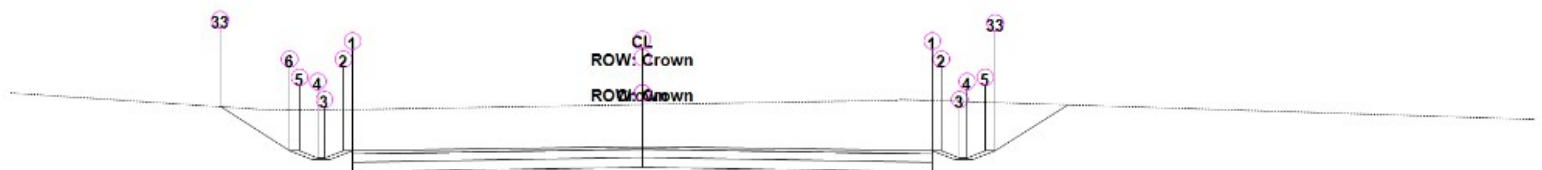

ALINHAMENTO LEOBERTO LEAL SC-408

Estaca: 1+560,00

Área de Corte: 9,65m<sup>2</sup>  
 Área de Aterro: 0,00m<sup>2</sup>  
 Volume Acumulado: 4.961,64m<sup>3</sup>  
 Cota Projeto: 539,138m

PLATAFORMA ACABADA LADO ESQUERDO	PTO	1	2	3	4	5	6	33
	DIST	3,300	3,409	3,618	3,698	3,907	4,016	4,813
	COTA	539,055m	539,055m	538,932m	538,932m	539,055m	539,055m	539,853m

PLATAFORMA ACABADA LADO DIREITO	PTO	1	2	3	4	5	33
	DIST	3,300m	3,409m	3,618m	3,698m	3,907m	4,016m
	COTA	539,055m	539,055m	538,932m	538,932m	539,055m	539,055m

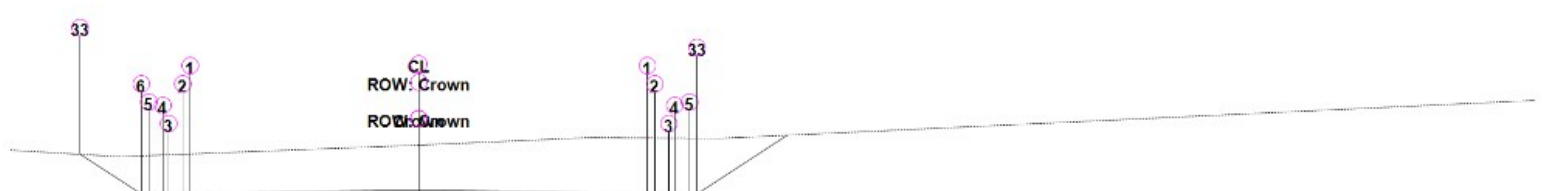

# ALINHAMENTO LEOBERTO LEAL SC-408

Estaca: 1+580,00

Área de Corte: 12,24m<sup>2</sup>  
 Área de Aterro: 0,00m<sup>2</sup>  
 Volume Acumulado: 5.180,98m<sup>3</sup>  
 Cota Projeto: 537,297m

PLATAFORMA ACABADA LADO ESQUERDO	PTO	1	2	3	4	5	6	33
	DIST	3,300	3,409	3,618	3,698	3,907	4,016	4,895
	COTA	537,215m	537,215m	537,092m	537,092m	537,215m	537,215m	538,094m

PLATAFORMA ACABADA LADO DIREITO	PTO	1	2	3	4	5	33
	DIST	3,300m	3,409m	3,618m	3,698m	3,907m	4,016m
	COTA	537,215m	537,215m	537,092m	537,092m	537,215m	537,215m

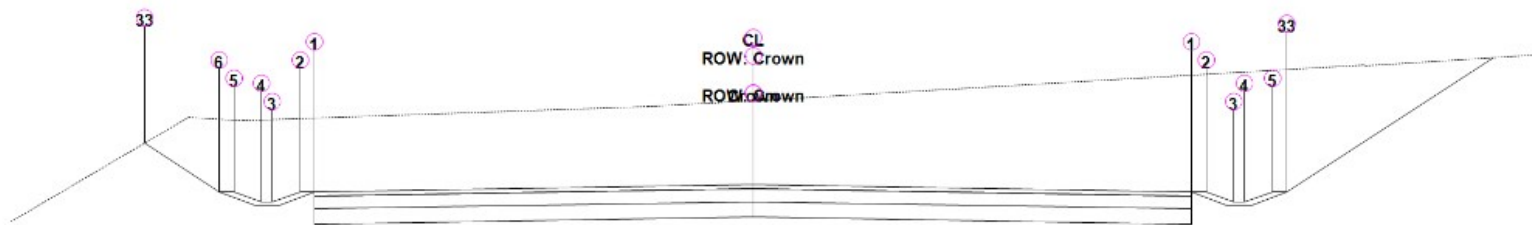

## ALINHAMENTO LEOBERTO LEAL SC-408

Estaca: 1+590,01

Área de Corte: 12,44m<sup>2</sup>  
 Área de Aterro: 0,00m<sup>2</sup>  
 Volume Acumulado: 5.304,88m<sup>3</sup>  
 Cota Projeto: 536,379m

PLATAFORMA ACABADA LADO ESQUERDO	PTO	1	2	3	4	5	6	33
	DIST	3,300	3,409	3,618	3,698	3,907	4,016	4,580
	COTA	536,297m	536,297m	536,174m	536,174m	536,297m	536,297m	536,861m

PLATAFORMA ACABADA LADO DIREITO	PTO	1	2	3	4	5	33
	DIST	3,300m	3,409m	3,618m	3,698m	3,907m	4,016m
	COTA	536,297m	536,297m	536,174m	536,174m	536,297m	536,297m

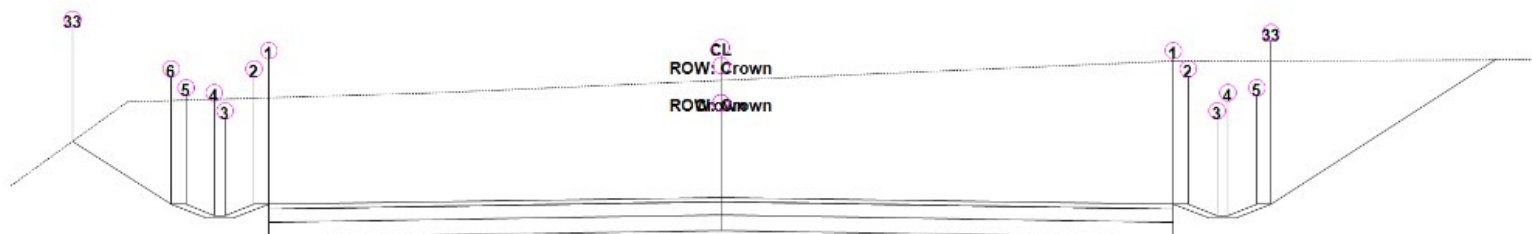

## ALINHAMENTO LEOBERTO LEAL SC-408

Estaca: 1+600,00

Área de Corte: 15,48m<sup>2</sup>  
 Área de Aterro: 0,00m<sup>2</sup>  
 Volume Acumulado: 5.447,32m<sup>3</sup>  
 Cota Projeto: 535,465m

PLATAFORMA ACABADA LADO ESQUERDO	PTO	1	2	3	4	5	6	33
	DIST	3,300	3,409	3,618	3,698	3,907	4,016	4,733
	COTA	535,382m	535,382m	535,259m	535,259m	535,382m	535,382m	536,099m

PLATAFORMA ACABADA LADO DIREITO	PTO	1	2	3	4	5	33
	DIST	3,300m	3,409m	3,618m	3,698m	3,907m	4,016m
	COTA	535,382m	535,382m	535,259m	535,259m	535,382m	535,382m

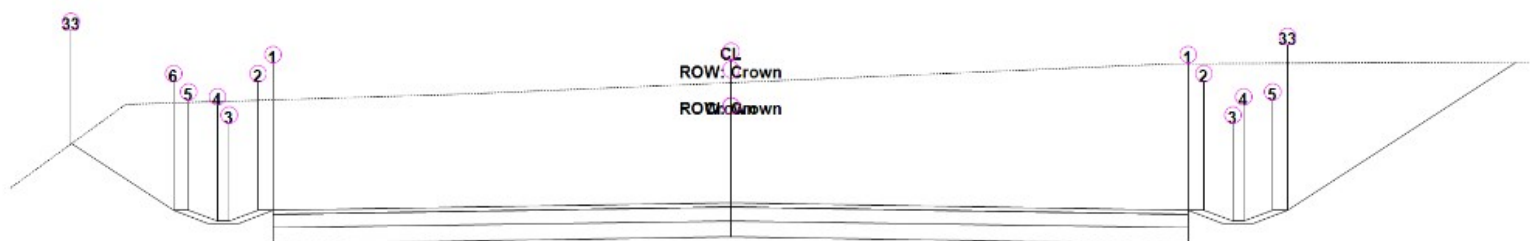

ALINHAMENTO LEOBERTO LEAL SC-408

Estaca: 1+600,32

Área de Corte: 15,63m<sup>2</sup>  
 Área de Aterro: 0,00m<sup>2</sup>  
 Volume Acumulado: 5.452,29m<sup>3</sup>  
 Cota Projeto: 535,435m

PLATAFORMA ACABADA LADO ESQUERDO	PTO	1	2	3	4	5	6	33
	DIST	3,300	3,409	3,618	3,698	3,907	4,016	4,756
	COTA	535,353m	535,353m	535,230m	535,230m	535,353m	535,353m	536,094m

PLATAFORMA ACABADA LADO DIREITO	PTO	1	2	3	4	5	33
	DIST	3,300m	3,409m	3,618m	3,698m	3,907m	4,016m
	COTA	535,353m	535,353m	535,230m	535,230m	535,353m	535,353m

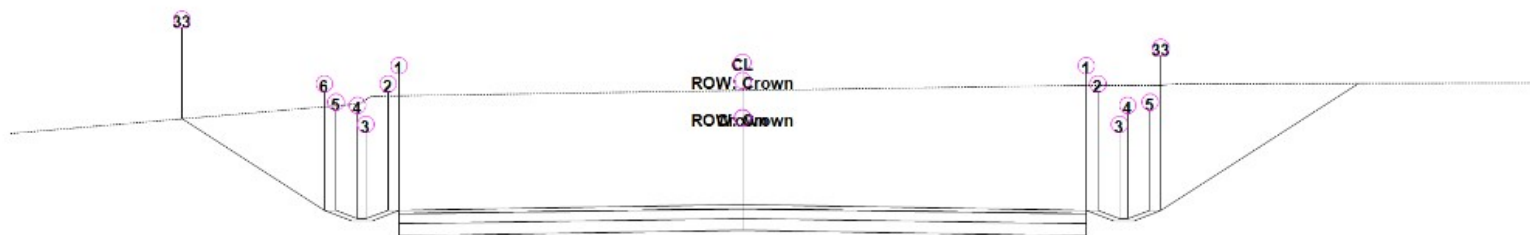

ALINHAMENTO LEOBERTO LEAL SC-408

Estaca: 1+610,63

Área de Corte: 19,53m<sup>2</sup>  
 Área de Aterro: 0,00m<sup>2</sup>

Volume Acumulado: 5.635,75m<sup>3</sup>  
 Cota Projeto: 534,494m

PLATAFORMA ACABADA LADO ESQUERDO	PTO	1	2	3	4	5	6	33
	DIST	3,300	3,409	3,618	3,698	3,907	4,016	5,383
	COTA	534,411m	534,411m	534,288m	534,288m	534,411m	534,411m	535,779m

PLATAFORMA ACABADA LADO DIREITO	PTO	1	2	3	4	5	33
	DIST	3,300m	3,409m	3,618m	3,698m	3,907m	4,016m
	COTA	534,411m	534,411m	534,288m	534,288m	534,411m	534,411m

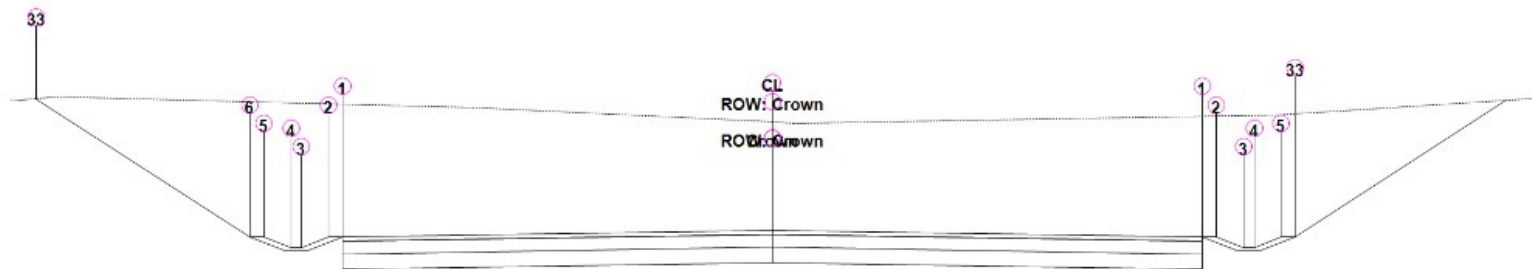

ALINHAMENTO LEOBERTO LEAL SC-408

Estaca: 1+620,00

Área de Corte: 16,58m<sup>2</sup>  
 Área de Aterro: 0,00m<sup>2</sup>  
 Volume Acumulado: 5.804,66m<sup>3</sup>  
 Cota Projeto: 533,640m

PLATAFORMA ACABADA LADO ESQUERDO	PTO	1	2	3	4	5	6	33
	DIST	3,300	3,409	3,618	3,698	3,907	4,016	5,655
	COTA	533,558m	533,558m	533,435m	533,435m	533,558m	533,558m	535,198m

PLATAFORMA ACABADA LADO DIREITO	PTO	1	2	3	4	5	33
	DIST	3,300m	3,409m	3,618m	3,698m	3,907m	4,016m
	COTA	533,558m	533,558m	533,435m	533,435m	533,558m	533,558m

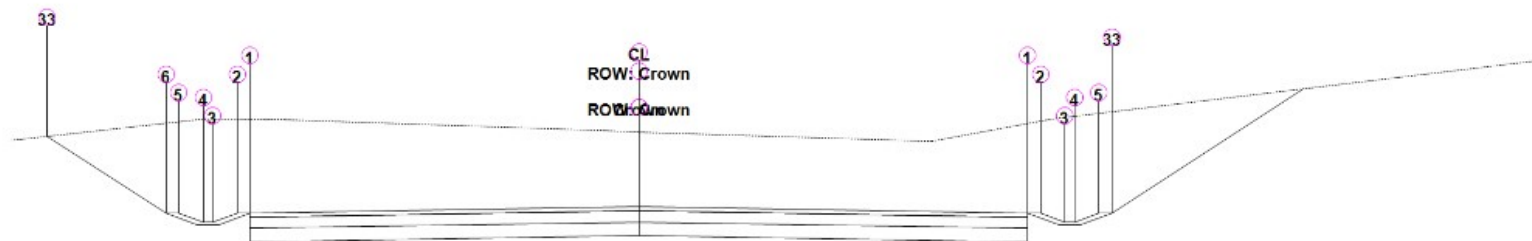

ALINHAMENTO LEOBERTO LEAL SC-408

Estaca: 1+632,66

Área de Corte: 13,02m<sup>2</sup>  
 Área de Aterro: 0,00m<sup>2</sup>  
 Volume Acumulado: 5.992,04m<sup>3</sup>  
 Cota Projeto: 532,488m

PLATAFORMA ACABADA LADO ESQUERDO	PTO	1	2	3	4	5	6	33
	DIST	3,300	3,409	3,618	3,698	3,907	4,016	5,028
	COTA	532,406m	532,406m	532,283m	532,283m	532,406m	532,406m	533,418m

PLATAFORMA ACABADA LADO DIREITO	PTO	1	2	3	4	5	33
	DIST	3,300m	3,409m	3,618m	3,698m	3,907m	4,016m
	COTA	532,406m	532,406m	532,283m	532,283m	532,406m	532,406m

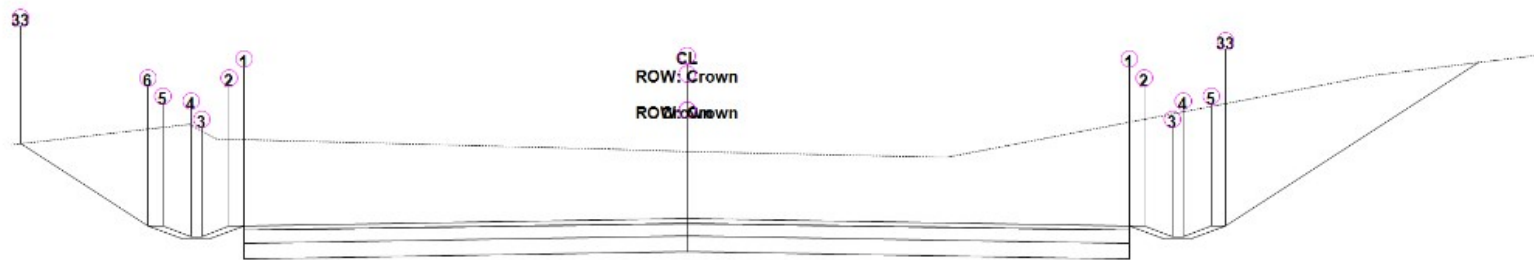

ALINHAMENTO LEOBERTO LEAL SC-408

Estaca: 1+640,00

Área de Corte: 12,02m<sup>2</sup>  
 Área de Aterro: 0,00m<sup>2</sup>  
 Volume Acumulado: 6.083,62m<sup>3</sup>  
 Cota Projeto: 531,820m

PLATAFORMA ACABADA LADO ESQUERDO	PTO	1	2	3	4	5	6	33
	DIST	3,300	3,409	3,618	3,698	3,907	4,016	4,968
	COTA	531,738m	531,738m	531,615m	531,615m	531,738m	531,738m	532,690m

PLATAFORMA ACABADA LADO DIREITO	PTO	1	2	3	4	5	33
	DIST	3,300m	3,409m	3,618m	3,698m	3,907m	4,016m
	COTA	531,738m	531,738m	531,615m	531,615m	531,738m	531,738m



ALINHAMENTO LEOBERTO LEAL SC-408

Estaca: 1+654,68

Área de Corte: 9,35m<sup>2</sup>  
 Área de Aterro: 0,00m<sup>2</sup>  
 Volume Acumulado: 6.239,51m<sup>3</sup>  
 Cota Projeto: 530,484m

PLATAFORMA ACABADA LADO ESQUERDO	PTO	1	2	3	4	5	6	33
	DIST	3,300	3,409	3,618	3,698	3,907	4,016	5,269
	COTA	530,401m	530,401m	530,278m	530,278m	530,401m	530,401m	531,655m

PLATAFORMA ACABADA LADO DIREITO	PTO	1	2	3	4	5	33
	DIST	3,300m	3,409m	3,618m	3,698m	3,907m	4,016m
	COTA	530,401m	530,401m	530,278m	530,278m	530,401m	530,401m

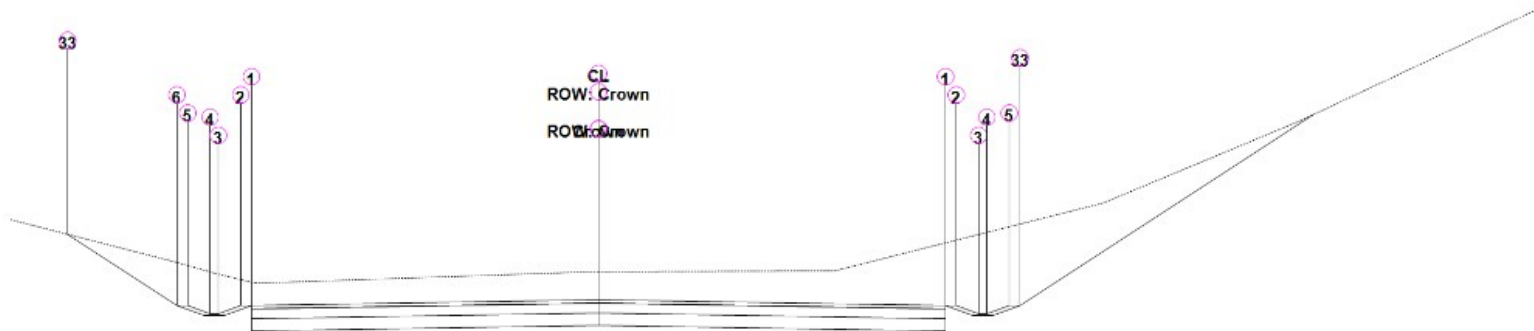

ALINHAMENTO LEOBERTO LEAL SC-408

Estaca: 1+660,00

Área de Corte: 8,44m<sup>2</sup>  
 Área de Aterro: 0,00m<sup>2</sup>  
 Volume Acumulado: 6.286,78m<sup>3</sup>  
 Cota Projeto: 530,000m

PLATAFORMA ACABADA LADO ESQUERDO	PTO	1	2	3	4	5	6	33
	DIST	3,300	3,409	3,618	3,698	3,907	4,016	5,052
	COTA	529,918m	529,918m	529,795m	529,795m	529,918m	529,918m	530,954m

PLATAFORMA ACABADA LADO DIREITO	PTO	1	2	3	4	5	33
	DIST	3,300m	3,409m	3,618m	3,698m	3,907m	4,016m
	COTA	529,918m	529,918m	529,795m	529,795m	529,918m	529,918m

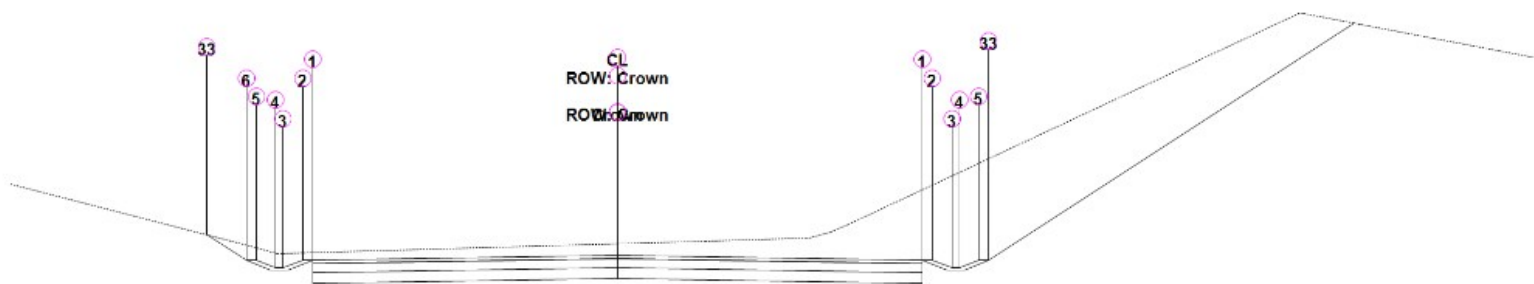

ALINHAMENTO LEOBERTO LEAL SC-408

Estaca: 1+668,23

Área de Corte: 10,22m<sup>2</sup>  
 Área de Aterro: 0,00m<sup>2</sup>  
 Volume Acumulado: 6.363,58m<sup>3</sup>  
 Cota Projeto: 529,251m

PLATAFORMA ACABADA LADO ESQUERDO	PTO	1	2	3	4	5	6	33
----------------------------------	-----	---	---	---	---	---	---	----



PLATAFORMA ACABADA LADO ESQUERDO	PTO	1	2	3	4	5	6	33
	DIST	3,300	3,409	3,618	3,698	3,907	4,016	4,443
	COTA	529,168m	529,168m	529,045m	529,045m	529,168m	529,168m	529,595m

PLATAFORMA ACABADA LADO DIREITO	PTO	1	2	3	4	5	33
	DIST	3,300m	3,409m	3,618m	3,698m	3,907m	4,016m
	COTA	529,168m	529,168m	529,045m	529,045m	529,168m	529,168m

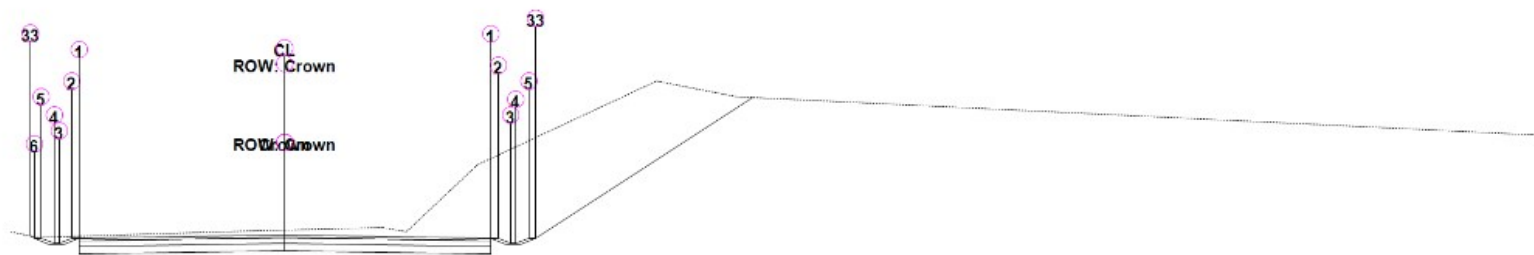

ALINHAMENTO LEOBERTO LEAL SC-408

Estaca: 1+677,61

Área de Corte: 12,24m<sup>2</sup>  
 Área de Aterro: 0,00m<sup>2</sup>  
 Volume Acumulado: 6.471,54m<sup>3</sup>  
 Cota Projeto: 528,397m

PLATAFORMA ACABADA LADO ESQUERDO	PTO	1	2	3	4	5	6	33
	DIST	3,300	3,409	3,618	3,698	3,907	4,016	4,080
	COTA	528,315m	528,315m	528,192m	528,192m	528,315m	528,315m	528,379m

PLATAFORMA ACABADA LADO DIREITO	PTO	1	2	3	4	5	33
	DIST	3,300m	3,409m	3,618m	3,698m	3,907m	4,016m
	COTA	528,315m	528,315m	528,192m	528,192m	528,315m	528,315m

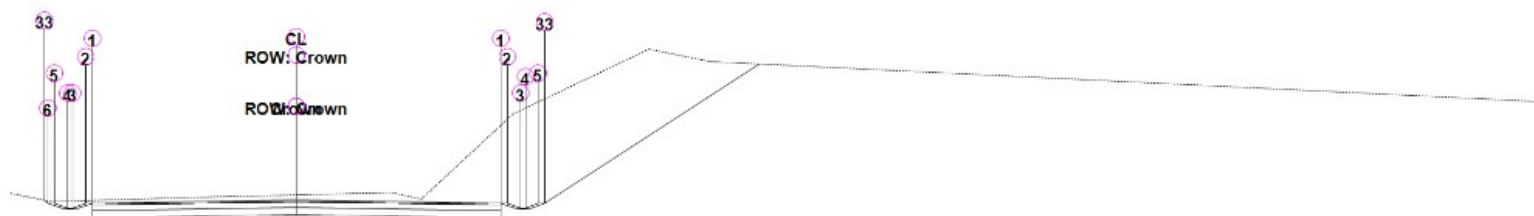

ALINHAMENTO LEOBERTO LEAL SC-408

Estaca: 1+680,00

Área de Corte: 12,07m<sup>2</sup>  
 Área de Aterro: 0,00m<sup>2</sup>  
 Volume Acumulado: 6.501,31m<sup>3</sup>  
 Cota Projeto: 528,180m

PLATAFORMA ACABADA LADO ESQUERDO	PTO	1	2	3	4	5	6	33
----------------------------------	-----	---	---	---	---	---	---	----

ACABADA	DIST	3,300	3,409	3,618	3,698	3,907	4,016	4,078
LADO ESQUERDO	COTA	528,098m	528,098m	527,975m	527,975m	528,098m	528,098m	528,160m

PLATAFORMA ACABADA LADO DIREITO	PTO	1	2	3	4	5	33
	DIST	3,300m	3,409m	3,618m	3,698m	3,907m	4,016m
	COTA	528,098m	528,098m	527,975m	527,975m	528,098m	528,098m

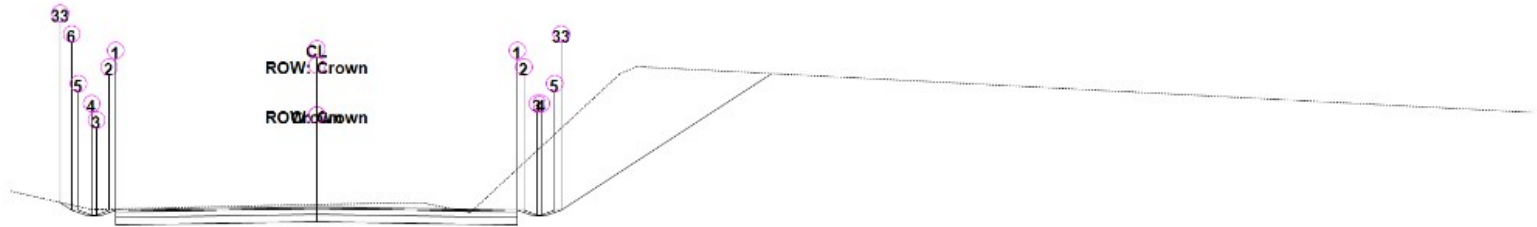

ALINHAMENTO LEOBERTO LEAL SC-408

Estaca: 1+686,99

Área de Corte: 10,02m<sup>2</sup>  
 Área de Aterro: 0,00m<sup>2</sup>  
 Volume Acumulado: 6.580,67m<sup>3</sup>  
 Cota Projeto: 527,544m

PLATAFORMA ACABADA LADO ESQUERDO	PTO	1	2	3	4	5	6	33
	DIST	3,300	3,409	3,618	3,698	3,907	4,016	4,206
	COTA	527,461m	527,461m	527,338m	527,338m	527,461m	527,461m	527,651m

PLATAFORMA ACABADA LADO DIREITO	PTO	1	2	3	4	5	33
	DIST	3,300m	3,409m	3,618m	3,698m	3,907m	4,016m
	COTA	527,461m	527,461m	527,338m	527,338m	527,461m	527,461m

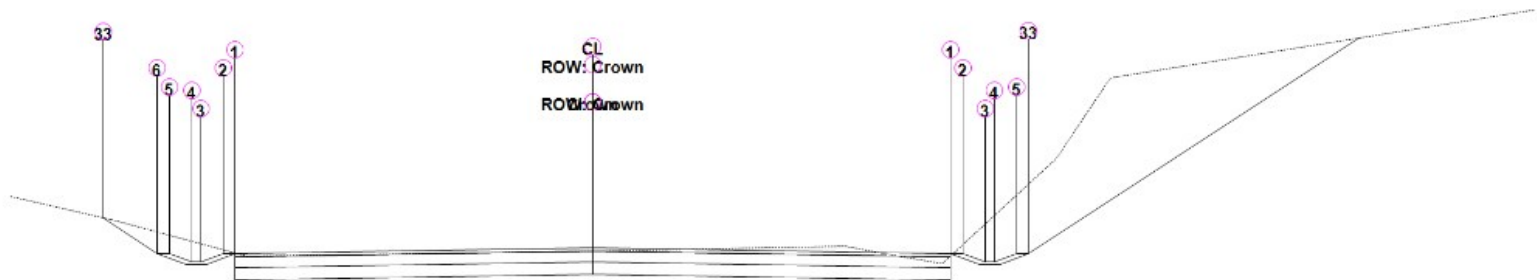

ALINHAMENTO LEOBERTO LEAL SC-408

Estaca: 1+697,69

Área de Corte: 5,96m<sup>2</sup>  
 Área de Aterro: 0,00m<sup>2</sup>  
 Volume Acumulado: 6.666,13m<sup>3</sup>  
 Cota Projeto: 526,570m

PLATAFORMA	PTO	1	2	3	4	5	6	33
------------	-----	---	---	---	---	---	---	----

ACABADA LADO ESQUERDO	DIST	3,300	3,409	3,618	3,698	3,907	4,016	4,518
	COTA	526,488m	526,488m	526,365m	526,365m	526,488m	526,488m	526,990m

PLATAFORMA ACABADA LADO DIREITO	PTO	1	2	3	4	5	33
	DIST	3,300m	3,409m	3,618m	3,698m	3,907m	4,016m
	COTA	526,488m	526,488m	526,365m	526,365m	526,488m	526,488m

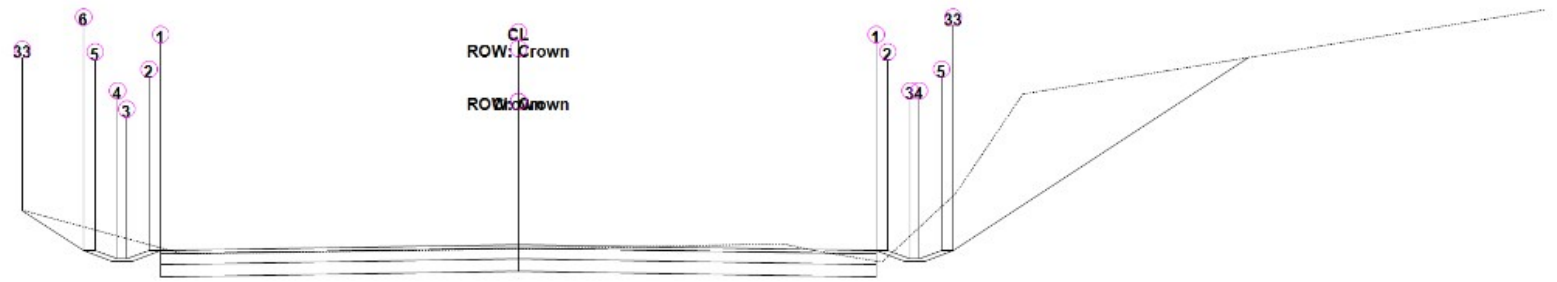

ALINHAMENTO LEOBERTO LEAL SC-408

Estaca: 1+700,00

Área de Corte: 5,23m<sup>2</sup>  
 Área de Aterro: 0,01m<sup>2</sup>  
 Volume Acumulado: 6.679,05m<sup>3</sup>  
 Cota Projeto: 526,360m

PLATAFORMA ACABADA LADO ESQUERDO	PTO	1	2	3	4	5	6	33
	DIST	3,300	3,409	3,618	3,698	3,907	4,016	4,577
	COTA	526,277m	526,277m	526,154m	526,154m	526,277m	526,277m	526,839m

PLATAFORMA ACABADA LADO DIREITO	PTO	1	2	3	4	5	33
	DIST	3,300m	3,409m	3,618m	3,698m	3,907m	4,016m
	COTA	526,277m	526,277m	526,154m	526,154m	526,277m	526,277m

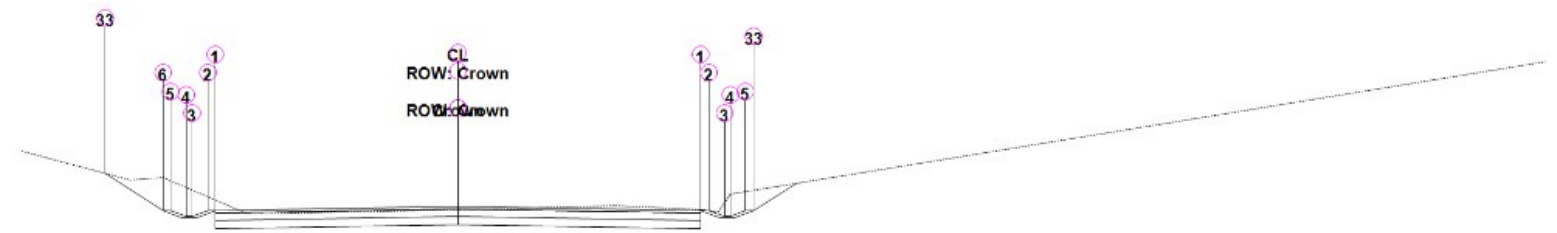

ALINHAMENTO LEOBERTO LEAL SC-408

Estaca: 1+715,69

Área de Corte: 3,41m<sup>2</sup>  
 Área de Aterro: 0,00m<sup>2</sup>  
 Volume Acumulado: 6.746,74m<sup>3</sup>  
 Cota Projeto: 524,932m

PLATAFORMA	PTO	1	2	3	4	5	6	33
------------	-----	---	---	---	---	---	---	----

PLATAFORMA ACABADA LADO ESQUERDO	PTO	1	2	3	4	5	6	33
	DIST	3,300	3,409	3,618	3,698	3,907	4,016	4,805
	COTA	524,850m	524,850m	524,727m	524,727m	524,850m	524,850m	525,639m

PLATAFORMA ACABADA LADO DIREITO	PTO	1	2	3	4	5	33
	DIST	3,300m	3,409m	3,618m	3,698m	3,907m	4,016m
	COTA	524,850m	524,850m	524,727m	524,727m	524,850m	524,850m

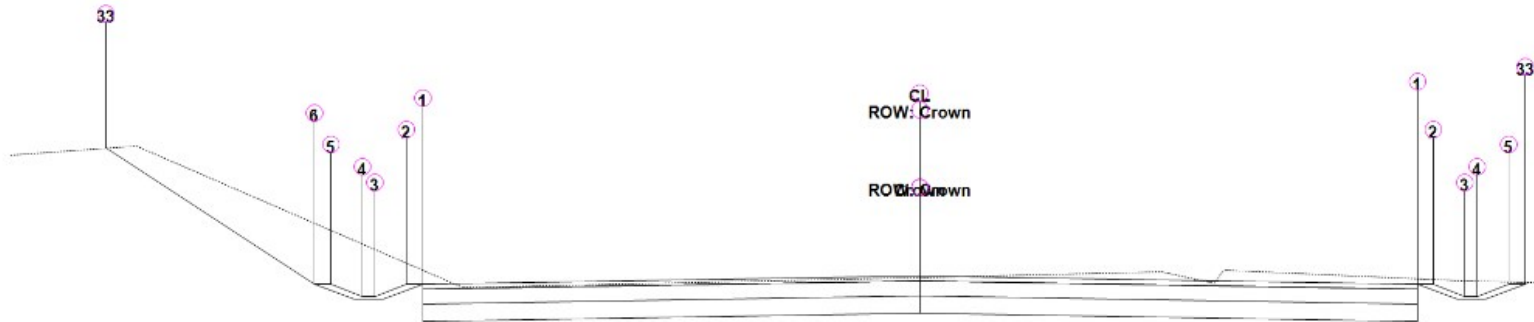

ALINHAMENTO LEOBERTO LEAL SC-408

Estaca: 1+720,00

Área de Corte: 3,58m<sup>2</sup>  
 Área de Aterro: 0,00m<sup>2</sup>  
 Volume Acumulado: 6.761,82m<sup>3</sup>  
 Cota Projeto: 524,540m

PLATAFORMA ACABADA LADO ESQUERDO	PTO	1	2	3	4	5	6	33
	DIST	3,300	3,409	3,618	3,698	3,907	4,016	5,405
	COTA	524,457m	524,457m	524,334m	524,334m	524,457m	524,457m	525,847m

PLATAFORMA ACABADA LADO DIREITO	PTO	1	2	3	4	5	33
	DIST	3,300m	3,409m	3,618m	3,698m	3,907m	4,016m
	COTA	524,457m	524,457m	524,334m	524,334m	524,457m	524,457m

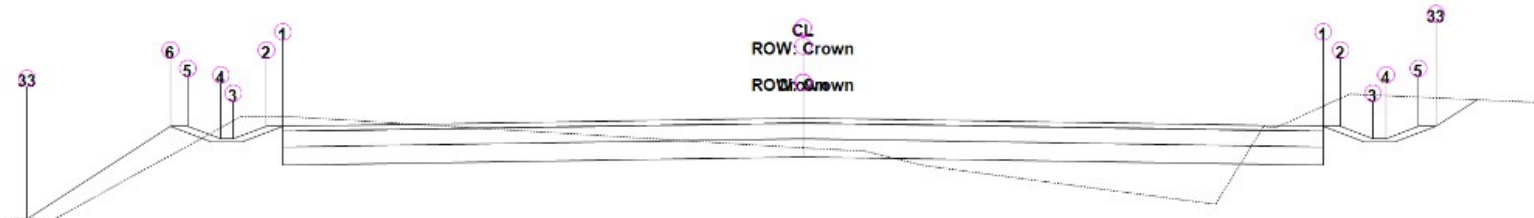

ALINHAMENTO LEOBERTO LEAL SC-408

Estaca: 1+733,69

Área de Corte: 1,57m<sup>2</sup>  
 Área de Aterro: 0,69m<sup>2</sup>  
 Volume Acumulado: 6.792,31m<sup>3</sup>  
 Cota Projeto: 523,294m

PLATAFORMA ACABADA LADO	PTO	1	2	3	4	5	6	33
	DIST	3,300	3,409	3,618	3,698	3,907	4,016	4,928

LADO ESQUERDO	COTA	523,212m	523,212m	523,089m	523,089m	523,212m	523,212m	522,299m
---------------	------	----------	----------	----------	----------	----------	----------	----------

PLATAFORMA ACABADA LADO DIREITO	PTO	1	2	3	4	5	33
	DIST	3,300m	3,409m	3,618m	3,698m	3,907m	4,016m
	COTA	523,212m	523,212m	523,089m	523,089m	523,212m	523,212m

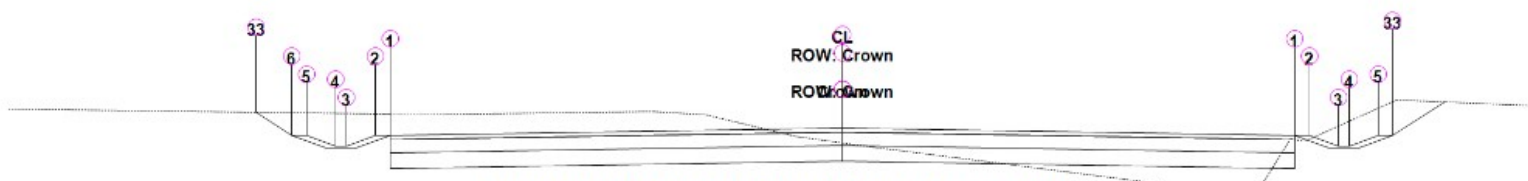

ALINHAMENTO LEOBERTO LEAL SC-408

Estaca: 1+740,00

Área de Corte: 2,44m<sup>2</sup>  
 Área de Aterro: 0,32m<sup>2</sup>  
 Volume Acumulado: 6.801,82m<sup>3</sup>  
 Cota Projeto: 522,720m

PLATAFORMA ACABADA LADO ESQUERDO	PTO	1	2	3	4	5	6	33
	DIST	3,300	3,409	3,618	3,698	3,907	4,016	4,280
	COTA	522,637m	522,637m	522,514m	522,514m	522,637m	522,637m	522,901m

PLATAFORMA ACABADA LADO DIREITO	PTO	1	2	3	4	5	33
	DIST	3,300m	3,409m	3,618m	3,698m	3,907m	4,016m
	COTA	522,637m	522,637m	522,514m	522,514m	522,637m	522,637m

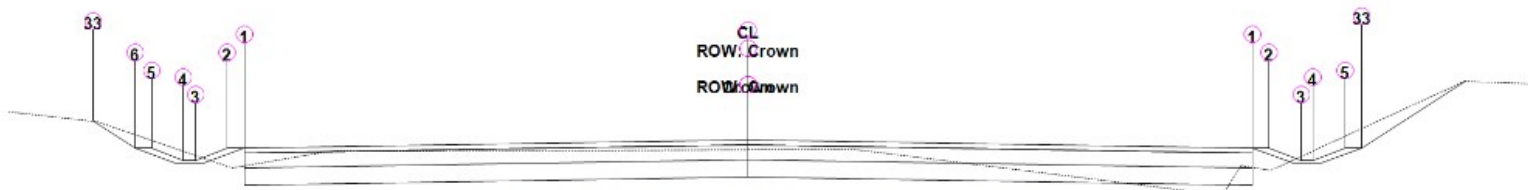

ALINHAMENTO LEOBERTO LEAL SC-408

Estaca: 1+758,85

Área de Corte: 1,69m<sup>2</sup>  
 Área de Aterro: 0,09m<sup>2</sup>  
 Volume Acumulado: 6.837,16m<sup>3</sup>  
 Cota Projeto: 521,005m

PLATAFORMA ACABADA LADO ESQUERDO	PTO	1	2	3	4	5	6	33
	DIST	3,300	3,409	3,618	3,698	3,907	4,016	4,291
	COTA	520,922m	520,922m	520,799m	520,799m	520,922m	520,922m	521,197m

PLATAFORMA ACABADA LADO DIREITO	PTO	1	2	3	4	5	33
	DIST	3,300m	3,409m	3,618m	3,698m	3,907m	4,016m
	COTA	520,922m	520,922m	520,799m	520,799m	520,922m	520,922m

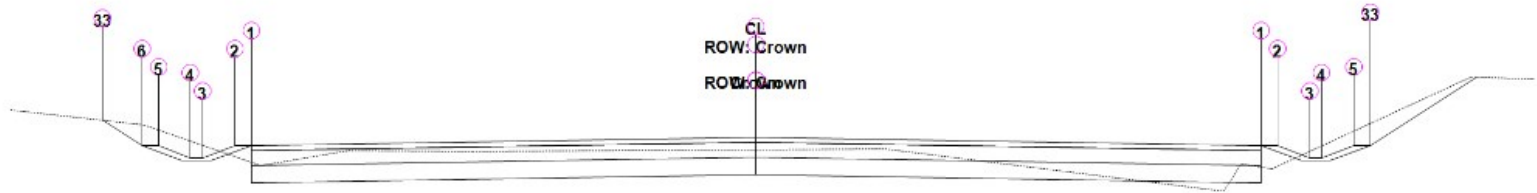

ALINHAMENTO LEOBERTO LEAL SC-408

Estaca: 1+760,00

Área de Corte: 1,69m<sup>2</sup>  
 Área de Aterro: 0,07m<sup>2</sup>  
 Volume Acumulado: 6.839,03m<sup>3</sup>  
 Cota Projeto: 520,900m

PLATAFORMA ACABADA LADO ESQUERDO	PTO	1	2	3	4	5	6	33
	DIST	3,300	3,409	3,618	3,698	3,907	4,016	4,274
	COTA	520,817m	520,817m	520,694m	520,694m	520,817m	520,817m	521,075m

PLATAFORMA ACABADA LADO DIREITO	PTO	1	2	3	4	5	33
	DIST	3,300m	3,409m	3,618m	3,698m	3,907m	4,016m
	COTA	520,817m	520,817m	520,694m	520,694m	520,817m	520,817m

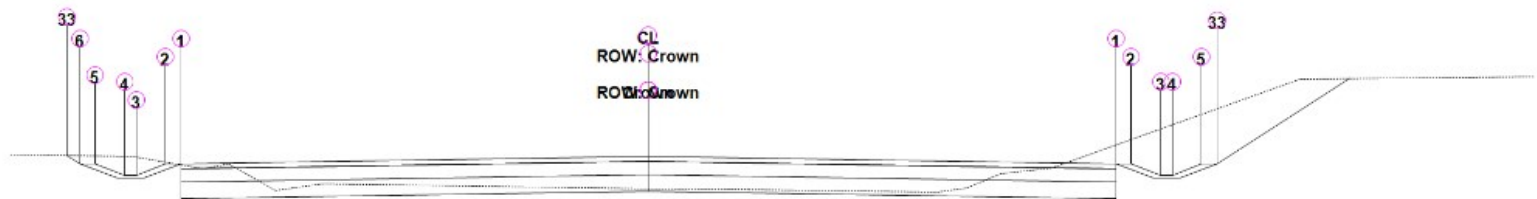

ALINHAMENTO LEOBERTO LEAL SC-408

Estaca: 1+780,00

Área de Corte: 1,68m<sup>2</sup>  
 Área de Aterro: 0,00m<sup>2</sup>  
 Volume Acumulado: 6.872,01m<sup>3</sup>  
 Cota Projeto: 519,079m

PLATAFORMA ACABADA LADO ESQUERDO	PTO	1	2	3	4	5	6	33
	DIST	3,300	3,409	3,618	3,698	3,907	4,016	4,110
	COTA	518,997m	518,997m	518,874m	518,874m	518,997m	518,997m	519,091m

PLATAFORMA ACABADA LADO DIREITO	PTO	1	2	3	4	5	33
	DIST	3,300m	3,409m	3,618m	3,698m	3,907m	4,016m
	COTA	518,997m	518,997m	518,874m	518,874m	518,997m	518,997m



ALINHAMENTO LEOBERTO LEAL SC-408

Estaca: 1+784,00

Área de Corte: 1,31m<sup>2</sup>  
 Área de Aterro: 0,01m<sup>2</sup>  
 Volume Acumulado: 6.877,94m<sup>3</sup>  
 Cota Projeto: 518,715m

PLATAFORMA ACABADA LADO ESQUERDO	PTO	1	2	3	4	5	6	33
	DIST	3,300	3,409	3,618	3,698	3,907	4,016	4,045
	COTA	518,633m	518,633m	518,510m	518,510m	518,633m	518,633m	518,662m

PLATAFORMA ACABADA LADO DIREITO	PTO	1	2	3	4	5	33
	DIST	3,300m	3,409m	3,618m	3,698m	3,907m	4,016m
	COTA	518,633m	518,633m	518,510m	518,510m	518,633m	518,633m

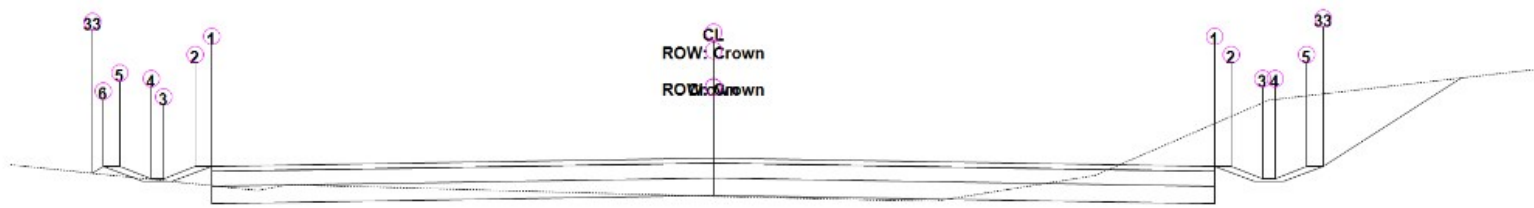

ALINHAMENTO LEOBERTO LEAL SC-408

Estaca: 1+800,00

Área de Corte: 1,76m<sup>2</sup>  
 Área de Aterro: 0,06m<sup>2</sup>  
 Volume Acumulado: 6.901,80m<sup>3</sup>  
 Cota Projeto: 517,259m

PLATAFORMA ACABADA LADO ESQUERDO	PTO	1	2	3	4	5	6	33
	DIST	3,300	3,409	3,618	3,698	3,907	4,016	4,084
	COTA	517,177m	517,177m	517,054m	517,054m	517,177m	517,177m	517,108m

PLATAFORMA ACABADA LADO DIREITO	PTO	1	2	3	4	5	33
	DIST	3,300m	3,409m	3,618m	3,698m	3,907m	4,016m
	COTA	517,177m	517,177m	517,054m	517,054m	517,177m	517,177m



ALINHAMENTO LEOBERTO LEAL SC-408

Estaca: 1+800,94

Área de Corte: 2,05m<sup>2</sup>  
 Área de Aterro: 0,03m<sup>2</sup>  
 Volume Acumulado: 6.903,54m<sup>3</sup>  
 Cota Projeto: 517,174m

PLATAFORMA ACABADA LADO ESQUERDO	PTO	1	2	3	4	5	6	33
	DIST	3,300	3,409	3,618	3,698	3,907	4,016	4,069
	COTA	517,091m	517,091m	516,968m	516,968m	517,091m	517,091m	517,038m

PLATAFORMA ACABADA LADO DIREITO	PTO	1	2	3	4	5	33
	DIST	3,300m	3,409m	3,618m	3,698m	3,907m	4,016m
	COTA	517,091m	517,091m	516,968m	516,968m	517,091m	517,091m

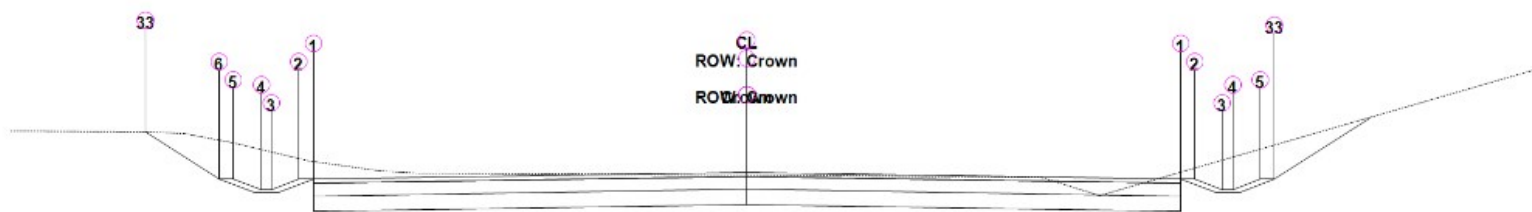

ALINHAMENTO LEOBERTO LEAL SC-408

Estaca: 1+817,87

Área de Corte: 3,33m<sup>2</sup>  
 Área de Aterro: 0,00m<sup>2</sup>  
 Volume Acumulado: 6.948,68m<sup>3</sup>  
 Cota Projeto: 515,633m

PLATAFORMA ACABADA LADO ESQUERDO	PTO	1	2	3	4	5	6	33
	DIST	3,300	3,409	3,618	3,698	3,907	4,016	4,578
	COTA	515,550m	515,550m	515,427m	515,427m	515,550m	515,550m	516,112m

PLATAFORMA ACABADA LADO DIREITO	PTO	1	2	3	4	5	33
	DIST	3,300m	3,409m	3,618m	3,698m	3,907m	4,016m
	COTA	515,550m	515,550m	515,427m	515,427m	515,550m	515,550m

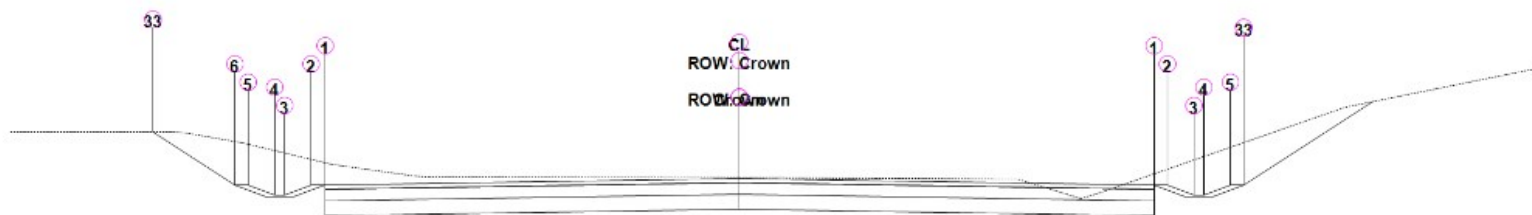

ALINHAMENTO LEOBERTO LEAL SC-408

Estaca: 1+820,00

Área de Corte: 3,90m<sup>2</sup>  
 Área de Aterro: 0,00m<sup>2</sup>  
 Volume Acumulado: 6.956,30m<sup>3</sup>



Volume Acumulado: 6.956,59m3  
 Cota Projeto: 515,439m

PLATAFORMA ACABADA LADO ESQUERDO	PTO	1	2	3	4	5	6	33
	DIST	3,300	3,409	3,618	3,698	3,907	4,016	4,671
	COTA	515,357m	515,357m	515,234m	515,234m	515,357m	515,357m	516,012m

PLATAFORMA ACABADA LADO DIREITO	PTO	1	2	3	4	5	33
	DIST	3,300m	3,409m	3,618m	3,698m	3,907m	4,016m
	COTA	515,357m	515,357m	515,234m	515,234m	515,357m	515,357m



ALINHAMENTO LEOBERTO LEAL SC-408

Estaca: 1+829,72

Área de Corte: 6,14m2  
 Área de Aterro: 0,00m2  
 Volume Acumulado: 7.005,11m3  
 Cota Projeto: 514,555m

PLATAFORMA ACABADA LADO ESQUERDO	PTO	1	2	3	4	5	6	33
	DIST	3,300	3,409	3,618	3,698	3,907	4,016	4,711
	COTA	514,472m	514,472m	514,349m	514,349m	514,472m	514,472m	515,167m

PLATAFORMA ACABADA LADO DIREITO	PTO	1	2	3	4	5	33
	DIST	3,300m	3,409m	3,618m	3,698m	3,907m	4,016m
	COTA	514,472m	514,472m	514,349m	514,349m	514,472m	514,472m



ALINHAMENTO LEOBERTO LEAL SC-408

Estaca: 1+840,00

Área de Corte: 8,27m2  
 Área de Aterro: 0,00m2  
 Volume Acumulado: 7.078,39m3  
 Cota Projeto: 513,619m

PLATAFORMA ACABADA LADO ESQUERDO	PTO	1	2	3	4	5	6	33
----------------------------------	-----	---	---	---	---	---	---	----

PLATAFORMA ACABADA LADO ESQUERDO	PTO	1	2	3	4	5	6	33
	DIST	3,300	3,409	3,618	3,698	3,907	4,016	4,624
	COTA	513,537m	513,537m	513,414m	513,414m	513,537m	513,537m	514,145m

PLATAFORMA ACABADA LADO DIREITO	PTO	1	2	3	4	5	33
	DIST	3,300m	3,409m	3,618m	3,698m	3,907m	4,016m
	COTA	513,537m	513,537m	513,414m	513,414m	513,537m	513,537m



ALINHAMENTO LEOBERTO LEAL SC-408

Estaca: 1+841,56

Área de Corte: 9,33m<sup>2</sup>  
 Área de Aterro: 0,00m<sup>2</sup>  
 Volume Acumulado: 7.091,86m<sup>3</sup>  
 Cota Projeto: 513,477m

PLATAFORMA ACABADA LADO ESQUERDO	PTO	1	2	3	4	5	6	33
	DIST	3,300	3,409	3,618	3,698	3,907	4,016	4,422
	COTA	513,394m	513,394m	513,271m	513,271m	513,394m	513,394m	513,800m

PLATAFORMA ACABADA LADO DIREITO	PTO	1	2	3	4	5	33
	DIST	3,300m	3,409m	3,618m	3,698m	3,907m	4,016m
	COTA	513,394m	513,394m	513,271m	513,271m	513,394m	513,394m

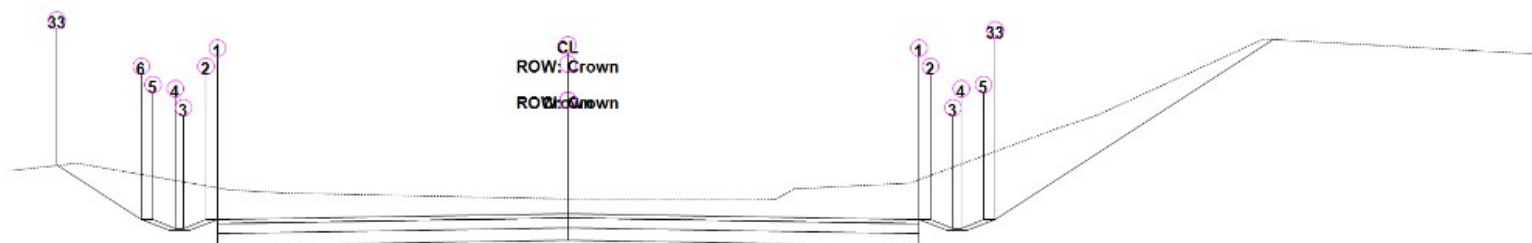

ALINHAMENTO LEOBERTO LEAL SC-408

Estaca: 1+857,64

Área de Corte: 7,31m<sup>2</sup>  
 Área de Aterro: 0,00m<sup>2</sup>  
 Volume Acumulado: 7.224,63m<sup>3</sup>  
 Cota Projeto: 512,014m

PLATAFORMA ACABADA LADO ESQUERDO	PTO	1	2	3	4	5	6	33
	DIST	3,300	3,409	3,618	3,698	3,907	4,016	4,808

ESQUERDO	COTA	511,931m	511,931m	511,808m	511,808m	511,931m	511,931m	512,723m
----------	------	----------	----------	----------	----------	----------	----------	----------

PLATAFORMA ACABADA LADO DIREITO	PTO	1	2	3	4	5	33
	DIST	3,300m	3,409m	3,618m	3,698m	3,907m	4,016m
	COTA	511,931m	511,931m	511,808m	511,808m	511,931m	511,931m



ALINHAMENTO LEOBERTO LEAL SC-408

Estaca: 1+860,00

Área de Corte: 7,41m<sup>2</sup>  
 Área de Aterro: 0,00m<sup>2</sup>  
 Volume Acumulado: 7.242,00m<sup>3</sup>  
 Cota Projeto: 511,799m

PLATAFORMA ACABADA LADO ESQUERDO	PTO	1	2	3	4	5	6	33
	DIST	3,300	3,409	3,618	3,698	3,907	4,016	4,853
	COTA	511,716m	511,716m	511,593m	511,593m	511,716m	511,716m	512,554m

PLATAFORMA ACABADA LADO DIREITO	PTO	1	2	3	4	5	33
	DIST	3,300m	3,409m	3,618m	3,698m	3,907m	4,016m
	COTA	511,716m	511,716m	511,593m	511,593m	511,716m	511,716m

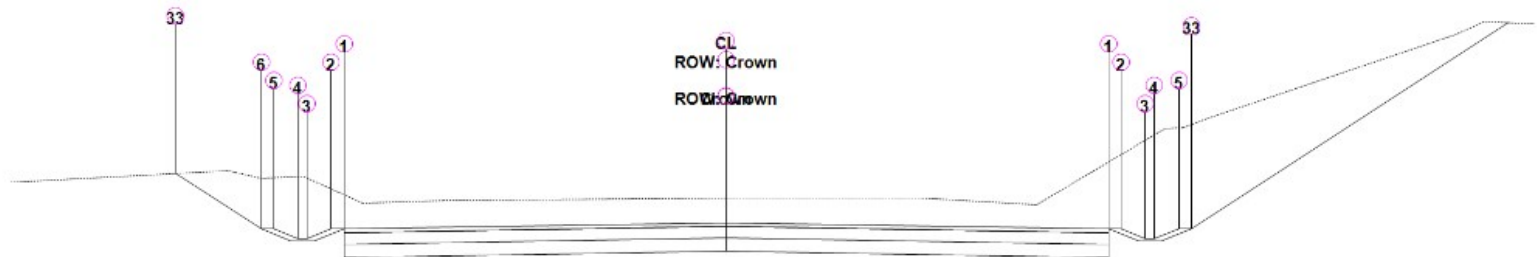

ALINHAMENTO LEOBERTO LEAL SC-408

Estaca: 1+873,72

Área de Corte: 8,69m<sup>2</sup>  
 Área de Aterro: 0,00m<sup>2</sup>  
 Volume Acumulado: 7.351,92m<sup>3</sup>  
 Cota Projeto: 510,584m

PLATAFORMA ACABADA LADO	PTO	1	2	3	4	5	6	33
	DIST	3,300	3,409	3,618	3,698	3,907	4,016	4,755
	COTA							

ESQUERDO	COTA	510,501m	510,501m	510,378m	510,378m	510,501m	510,501m	511,240m
----------	------	----------	----------	----------	----------	----------	----------	----------

PLATAFORMA ACABADA LADO DIREITO	PTO	1	2	3	4	5	33
	DIST	3,300m	3,409m	3,618m	3,698m	3,907m	4,016m
	COTA	510,501m	510,501m	510,378m	510,378m	510,501m	510,501m

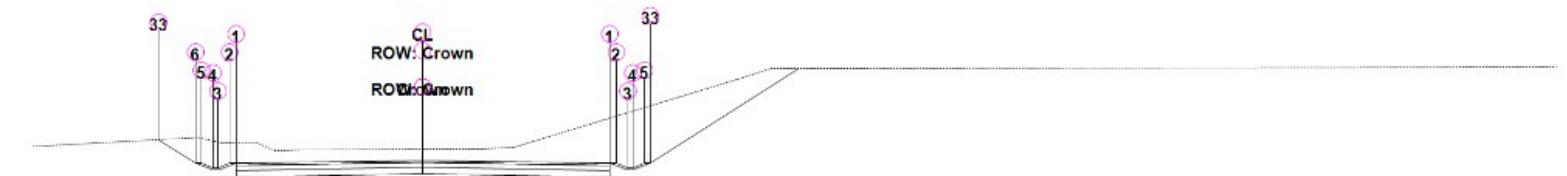

ALINHAMENTO LEOBERTO LEAL SC-408

Estaca: 1+880,00

Área de Corte: 9,78m<sup>2</sup>  
 Área de Aterro: 0,00m<sup>2</sup>  
 Volume Acumulado: 7.410,28m<sup>3</sup>  
 Cota Projeto: 510,059m

PLATAFORMA ACABADA LADO ESQUERDO	PTO	1	2	3	4	5	6	33
	DIST	3,300	3,409	3,618	3,698	3,907	4,016	4,666
	COTA	509,976m	509,976m	509,853m	509,853m	509,976m	509,976m	510,627m

PLATAFORMA ACABADA LADO DIREITO	PTO	1	2	3	4	5	33
	DIST	3,300m	3,409m	3,618m	3,698m	3,907m	4,016m
	COTA	509,976m	509,976m	509,853m	509,853m	509,976m	509,976m

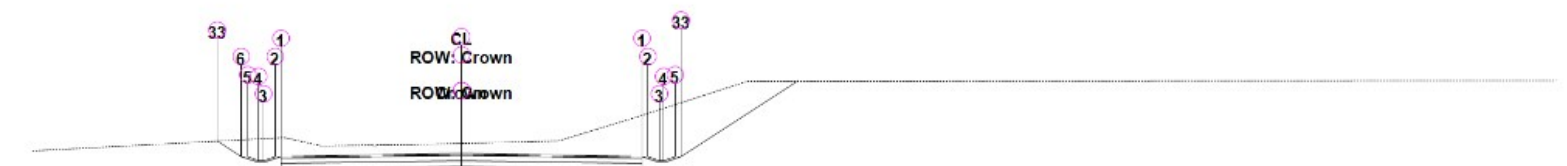

ALINHAMENTO LEOBERTO LEAL SC-408

Estaca: 1+890,04

Área de Corte: 8,86m<sup>2</sup>  
 Área de Aterro: 0,00m<sup>2</sup>  
 Volume Acumulado: 7.504,19m<sup>3</sup>  
 Cota Projeto: 509,262m

PLATAFORMA ACABADA LADO ESQUERDO	PTO	1	2	3	4	5	6	33
	DIST	3,300	3,409	3,618	3,698	3,907	4,016	4,462
	COTA	509,180m	509,180m	509,057m	509,057m	509,180m	509,180m	509,626m

PLATAFORMA ACABADA LADO DIREITO	PTO	1	2	3	4	5	33
	DIST	3,300m	3,409m	3,618m	3,698m	3,907m	4,016m
	COTA	509,180m	509,180m	509,057m	509,057m	509,180m	509,180m

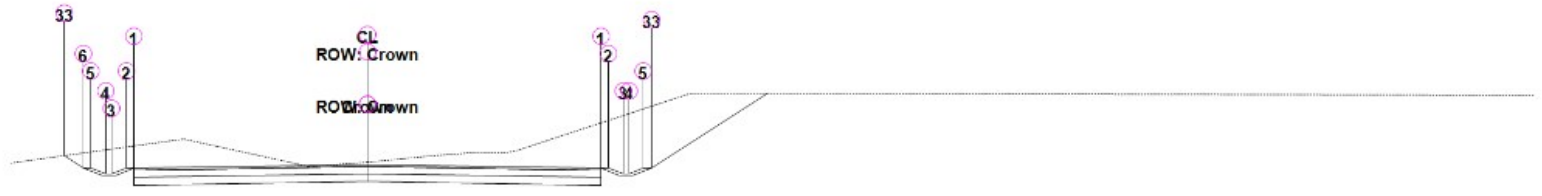

ALINHAMENTO LEOBERTO LEAL SC-408

Estaca: 1+900,00

Área de Corte: 7,33m<sup>2</sup>  
 Área de Aterro: 0,00m<sup>2</sup>  
 Volume Acumulado: 7.585,14m<sup>3</sup>  
 Cota Projeto: 508,523m

PLATAFORMA ACABADA LADO ESQUERDO	PTO	1	2	3	4	5	6	33
	DIST	3,300	3,409	3,618	3,698	3,907	4,016	4,292
	COTA	508,440m	508,440m	508,317m	508,317m	508,440m	508,440m	508,717m

PLATAFORMA ACABADA LADO DIREITO	PTO	1	2	3	4	5	33
	DIST	3,300m	3,409m	3,618m	3,698m	3,907m	4,016m
	COTA	508,440m	508,440m	508,317m	508,317m	508,440m	508,440m

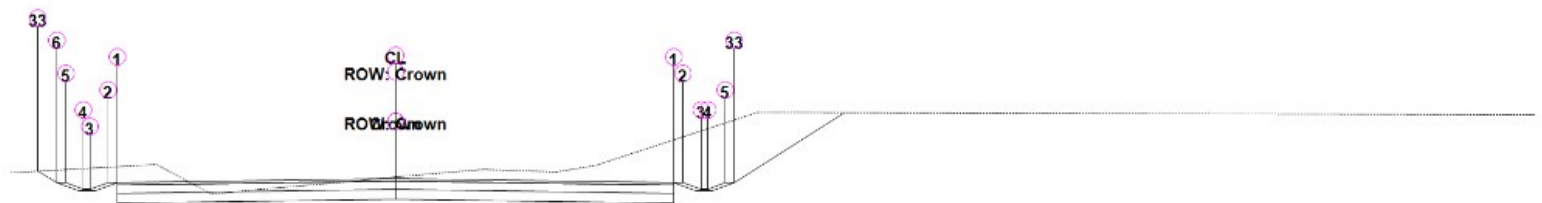

ALINHAMENTO LEOBERTO LEAL SC-408

Estaca: 1+906,36

Área de Corte: 5,21m<sup>2</sup>  
 Área de Aterro: 0,00m<sup>2</sup>  
 Volume Acumulado: 7.624,99m<sup>3</sup>  
 Cota Projeto: 508,078m

PLATAFORMA ACABADA LADO ESQUERDO	PTO	1	2	3	4	5	6	33
	DIST	3,300	3,409	3,618	3,698	3,907	4,016	4,234
	COTA	507,996m	507,996m	507,873m	507,873m	507,996m	507,996m	508,214m

PLATAFORMA ACABADA LADO DIREITO	PTO	1	2	3	4	5	33
	DIST	3,300m	3,409m	3,618m	3,698m	3,907m	4,016m
	COTA	507,996m	507,996m	507,873m	507,873m	507,996m	507,996m

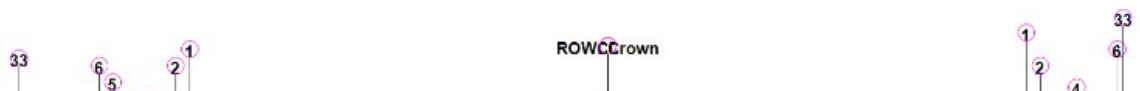

ALINHAMENTO LEOBERTO LEAL SC-408

Estaca: 1+920,00

Área de Corte: 0,65m<sup>2</sup>  
 Área de Aterro: 0,88m<sup>2</sup>  
 Volume Acumulado: 7.659,83m<sup>3</sup>  
 Cota Projeto: 507,194m

PLATAFORMA ACABADA LADO ESQUERDO	PTO	1	2	3	4	5	6	33
	DIST	3,300	3,409	3,618	3,698	3,907	4,016	4,650
	COTA	507,111m	507,111m	506,988m	506,988m	507,111m	507,111m	506,477m

PLATAFORMA ACABADA LADO DIREITO	PTO	1	2	3	4	5	6	33
	DIST	3,300m	3,409m	3,618m	3,698m	3,907m	4,016m	4,062m
	COTA	507,111m	507,111m	506,988m	506,988m	507,111m	507,111m	507,065m

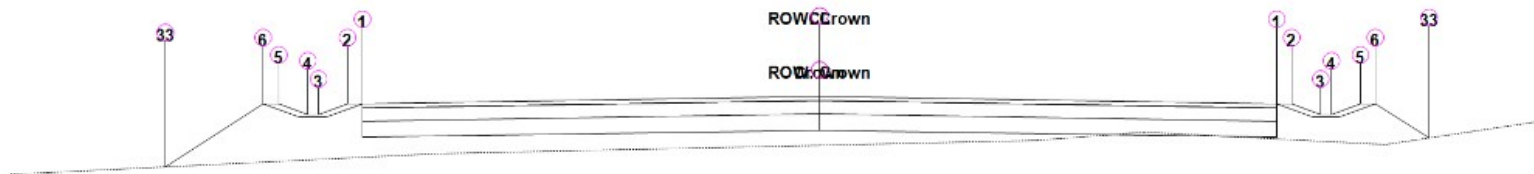

ALINHAMENTO LEOBERTO LEAL SC-408

Estaca: 1+928,66

Área de Corte: 0,01m<sup>2</sup>  
 Área de Aterro: 1,78m<sup>2</sup>  
 Volume Acumulado: 7.651,42m<sup>3</sup>  
 Cota Projeto: 506,682m

PLATAFORMA ACABADA LADO ESQUERDO	PTO	1	2	3	4	5	6	33
	DIST	3,300	3,409	3,618	3,698	3,907	4,016	4,726
	COTA	506,600m	506,600m	506,477m	506,477m	506,600m	506,600m	505,889m

PLATAFORMA ACABADA LADO DIREITO	PTO	1	2	3	4	5	6	33
	DIST	3,300m	3,409m	3,618m	3,698m	3,907m	4,016m	4,401m
	COTA	506,600m	506,600m	506,477m	506,477m	506,600m	506,600m	506,214m



ALINHAMENTO LEOBERTO LEAL SC-408

Estaca: 1+940,00

Área de Corte: 0,00m<sup>2</sup>  
 Área de Aterro: 2,56m<sup>2</sup>

Volume Acumulado: 7.627,02m<sup>3</sup>  
 Cota Projeto: 506,071m

PLATAFORMA ACABADA LADO ESQUERDO	PTO	1	2	3	4	5	6	33
	DIST	3,300	3,409	3,618	3,698	3,907	4,016	4,588
	COTA	505,988m	505,988m	505,865m	505,865m	505,988m	505,988m	505,416m

PLATAFORMA ACABADA LADO DIREITO	PTO	1	2	3	4	5	6	33
	DIST	3,300m	3,409m	3,618m	3,698m	3,907m	4,016m	4,563m
	COTA	505,988m	505,988m	505,865m	505,865m	505,988m	505,988m	505,440m

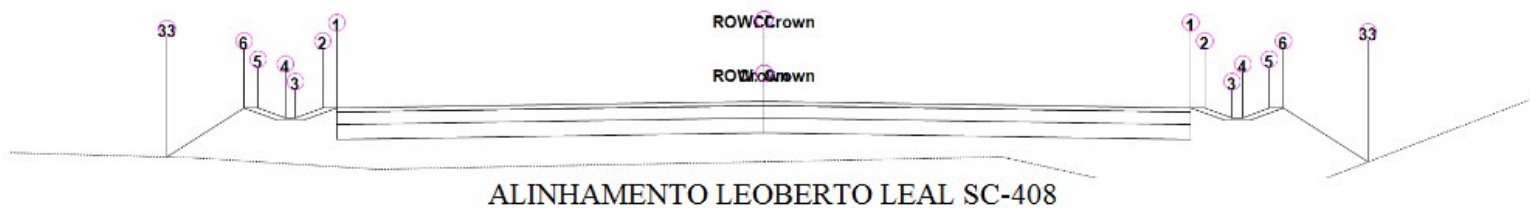

Estaca: 1+950,96

Área de Corte: 0,00m<sup>2</sup>  
 Área de Aterro: 4,03m<sup>2</sup>  
 Volume Acumulado: 7.590,89m<sup>3</sup>  
 Cota Projeto: 505,543m

PLATAFORMA ACABADA LADO ESQUERDO	PTO	1	2	3	4	5	6	33
	DIST	3,300	3,409	3,618	3,698	3,907	4,016	4,613
	COTA	505,460m	505,460m	505,337m	505,337m	505,460m	505,460m	504,863m

PLATAFORMA ACABADA LADO DIREITO	PTO	1	2	3	4	5	6	33
	DIST	3,300m	3,409m	3,618m	3,698m	3,907m	4,016m	4,669m
	COTA	505,460m	505,460m	505,337m	505,337m	505,460m	505,460m	504,807m

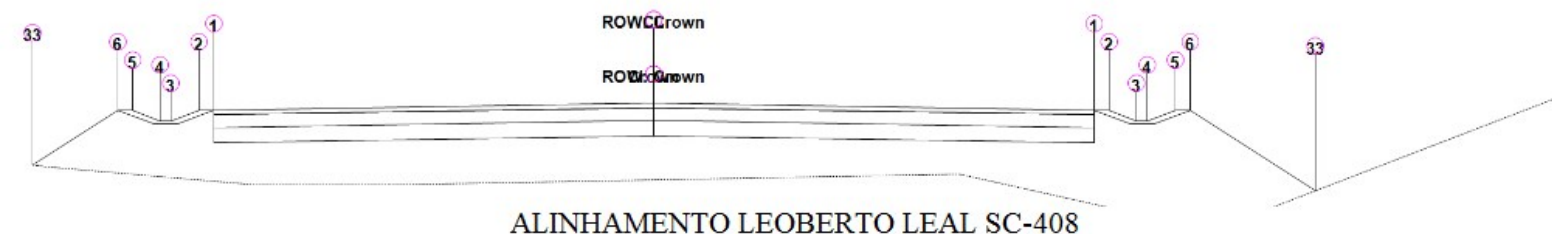

Estaca: 1+960,00

Área de Corte: 0,00m<sup>2</sup>  
 Área de Aterro: 5,51m<sup>2</sup>  
 Volume Acumulado: 7.547,69m<sup>3</sup>  
 Cota Projeto: 505,154m

PLATAFORMA ACABADA LADO ESQUERDO	PTO	1	2	3	4	5	6	33
	DIST	3,300	3,409	3,618	3,698	3,907	4,016	4,654
	COTA	505,071m	505,071m	504,948m	504,948m	505,071m	505,071m	504,433m

PLATAFORMA ACABADA LADO DIREITO	PTO	1	2	3	4	5	6	33
	DIST	3,300m	3,409m	3,618m	3,698m	3,907m	4,016m	4,955m
	COTA	505,071m	505,071m	504,948m	504,948m	505,071m	505,071m	504,132m

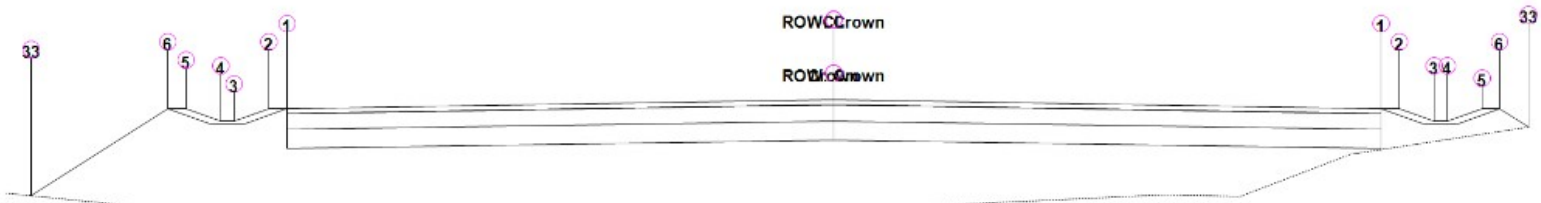

ALINHAMENTO LEOBERTO LEAL SC-408

Estaca: 1+980,00

Área de Corte: 0,00m<sup>2</sup>  
 Área de Aterro: 4,88m<sup>2</sup>  
 Volume Acumulado: 7.443,90m<sup>3</sup>  
 Cota Projeto: 504,443m

PLATAFORMA ACABADA LADO ESQUERDO	PTO	1	2	3	4	5	6	33
	DIST	3,300	3,409	3,618	3,698	3,907	4,016	4,839
	COTA	504,361m	504,361m	504,238m	504,238m	504,361m	504,361m	503,537m

PLATAFORMA ACABADA LADO DIREITO	PTO	1	2	3	4	5	6	33
	DIST	3,300m	3,409m	3,618m	3,698m	3,907m	4,016m	4,190m
	COTA	504,361m	504,361m	504,238m	504,238m	504,361m	504,361m	504,186m

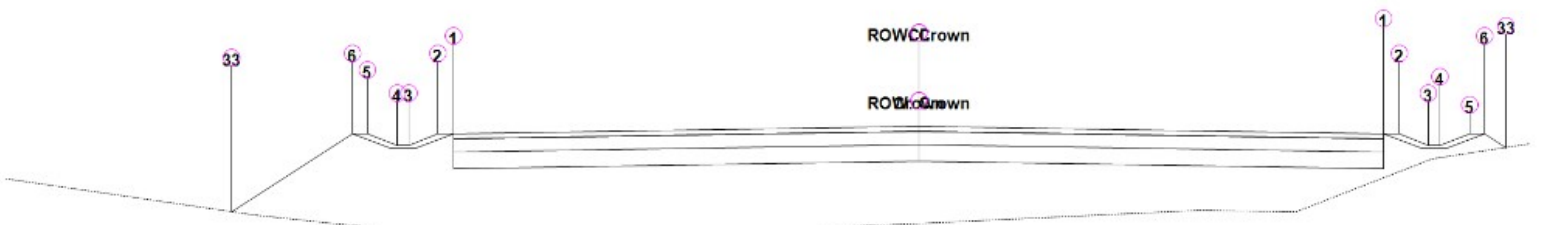

ALINHAMENTO LEOBERTO LEAL SC-408

Estaca: 1+986,75

Área de Corte: 0,00m<sup>2</sup>  
 Área de Aterro: 5,36m<sup>2</sup>  
 Volume Acumulado: 7.409,51m<sup>3</sup>  
 Cota Projeto: 504,250m

PLATAFORMA ACABADA LADO ESQUERDO	PTO	1	2	3	4	5	6	33
	DIST	3,300	3,409	3,618	3,698	3,907	4,016	4,872
	COTA	504,167m	504,167m	504,044m	504,044m	504,167m	504,167m	503,311m

PLATAFORMA ACABADA LADO DIREITO	PTO	1	2	3	4	5	6	33
	DIST	3,300m	3,409m	3,618m	3,698m	3,907m	4,016m	4,165m
	COTA	504,167m	504,167m	504,044m	504,044m	504,167m	504,167m	504,018m



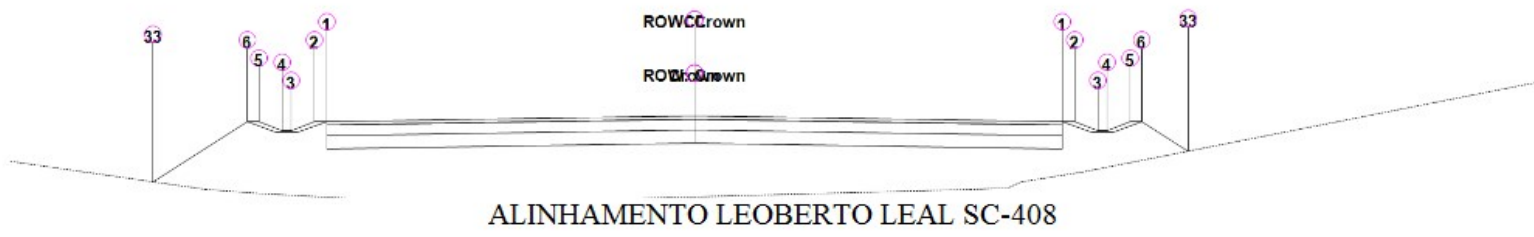

ALINHAMENTO LEOBERTO LEAL SC-408

Estaca: 2+000,00

Área de Corte: 0,00m<sup>2</sup>  
 Área de Aterro: 6,20m<sup>2</sup>  
 Volume Acumulado: 7.333,22m<sup>3</sup>  
 Cota Projeto: 503,938m

PLATAFORMA ACABADA LADO ESQUERDO	PTO	1	2	3	4	5	6	33
	DIST	3,300	3,409	3,618	3,698	3,907	4,016	4,860
	COTA	503,855m	503,855m	503,732m	503,732m	503,855m	503,855m	503,011m

PLATAFORMA ACABADA LADO DIREITO	PTO	1	2	3	4	5	6	33
	DIST	3,300m	3,409m	3,618m	3,698m	3,907m	4,016m	4,427m
	COTA	503,855m	503,855m	503,732m	503,732m	503,855m	503,855m	503,443m

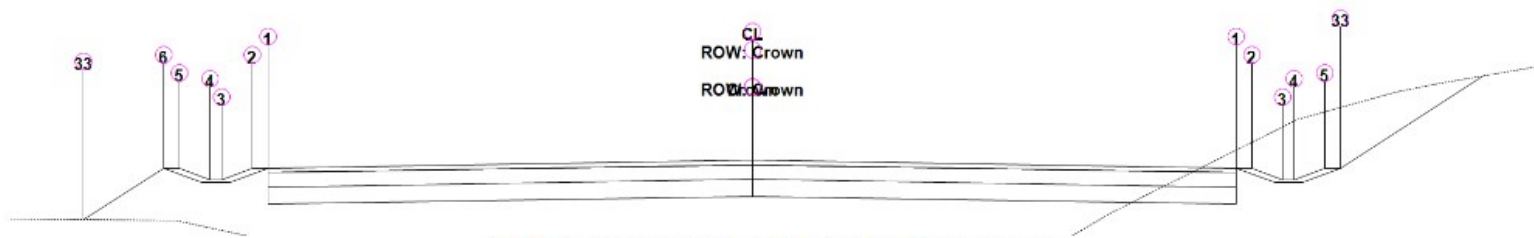

ALINHAMENTO LEOBERTO LEAL SC-408

Estaca: 2+020,00

Área de Corte: 0,92m<sup>2</sup>  
 Área de Aterro: 3,42m<sup>2</sup>  
 Volume Acumulado: 7.246,77m<sup>3</sup>  
 Cota Projeto: 503,516m

PLATAFORMA ACABADA LADO ESQUERDO	PTO	1	2	3	4	5	6	33
	DIST	3,300	3,409	3,618	3,698	3,907	4,016	4,561
	COTA	503,434m	503,434m	503,311m	503,311m	503,434m	503,434m	502,888m

PLATAFORMA ACABADA LADO DIREITO	PTO	1	2	3	4	5	33
	DIST	3,300m	3,409m	3,618m	3,698m	3,907m	4,016m
	COTA	503,434m	503,434m	503,311m	503,311m	503,434m	503,434m

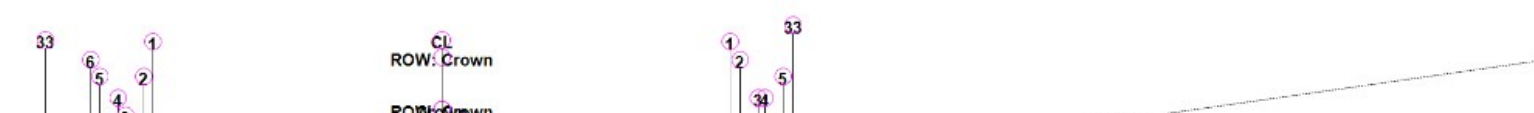

ALINHAMENTO LEOBERTO LEAL SC-408

Estaca: 2+022,55

Área de Corte: 0,73m<sup>2</sup>  
 Área de Aterro: 3,27m<sup>2</sup>  
 Volume Acumulado: 7.240,37m<sup>3</sup>  
 Cota Projeto: 503,462m

PLATAFORMA ACABADA LADO ESQUERDO	PTO	1	2	3	4	5	6	33
	DIST	3,300	3,409	3,618	3,698	3,907	4,016	4,536
	COTA	503,380m	503,380m	503,257m	503,257m	503,380m	503,380m	502,860m

PLATAFORMA ACABADA LADO DIREITO	PTO	1	2	3	4	5	33
	DIST	3,300m	3,409m	3,618m	3,698m	3,907m	4,016m
	COTA	503,380m	503,380m	503,257m	503,257m	503,380m	503,380m

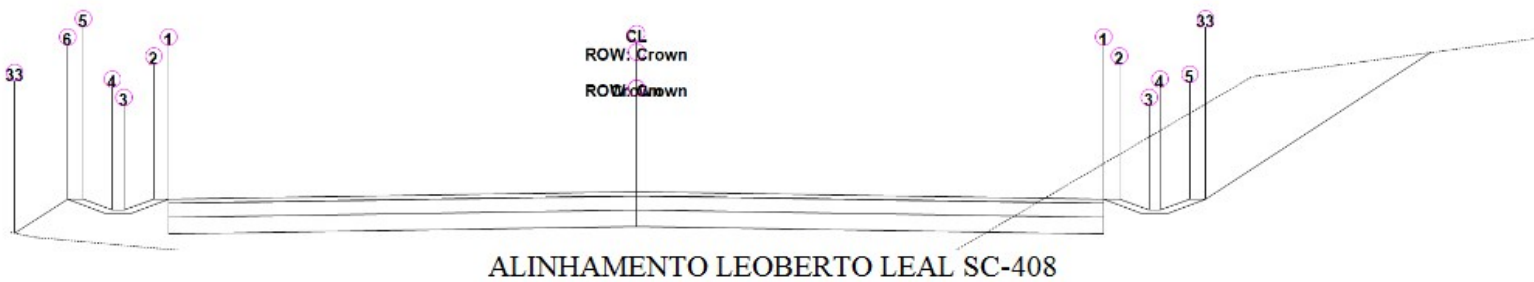

ALINHAMENTO LEOBERTO LEAL SC-408

Estaca: 2+040,00

Área de Corte: 1,87m<sup>2</sup>  
 Área de Aterro: 2,16m<sup>2</sup>  
 Volume Acumulado: 7.214,86m<sup>3</sup>  
 Cota Projeto: 503,094m

PLATAFORMA ACABADA LADO ESQUERDO	PTO	1	2	3	4	5	6	33
	DIST	3,300	3,409	3,618	3,698	3,907	4,016	4,389
	COTA	503,012m	503,012m	502,889m	502,889m	503,012m	503,012m	502,639m

PLATAFORMA ACABADA LADO DIREITO	PTO	1	2	3	4	5	33
	DIST	3,300m	3,409m	3,618m	3,698m	3,907m	4,016m
	COTA	503,012m	503,012m	502,889m	502,889m	503,012m	503,012m



ALINHAMENTO LEOBERTO LEAL SC-408

Estaca: 2+054,39

Área de Corte: 0,89m<sup>2</sup>  
 Área de Aterro: 2,57m<sup>2</sup>  
 Volume Acumulado: 7.199,71m<sup>3</sup>  
 Cota Projeto: 502,797m

PLATAFORMA ACABADA LADO ESQUERDO	PTO	1	2	3	4	5	6	33
	DIST	3,300	3,409	3,618	3,698	3,907	4,016	4,726
	COTA	502,714m	502,714m	502,591m	502,591m	502,714m	502,714m	502,004m

PLATAFORMA ACABADA LADO DIREITO	PTO	1	2	3	4	5	33
	DIST	3,300m	3,409m	3,618m	3,698m	3,907m	4,016m
	COTA	502,714m	502,714m	502,591m	502,591m	502,714m	502,714m

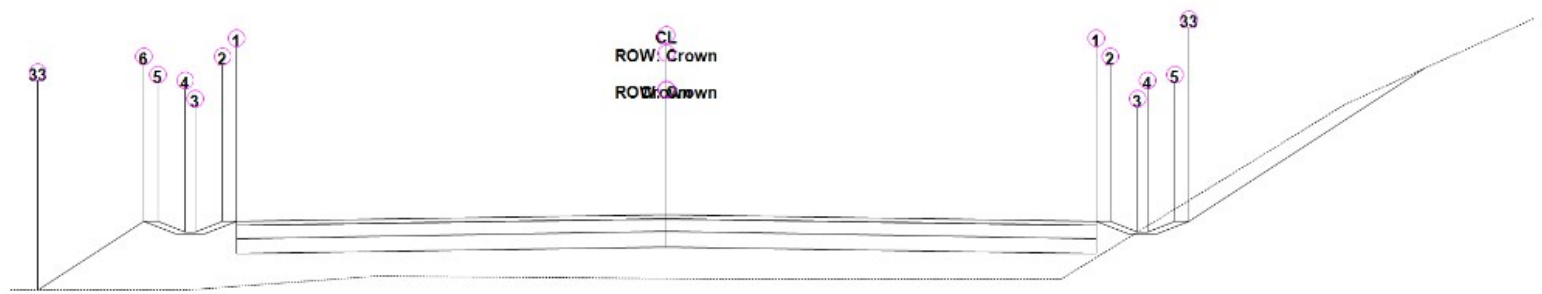

ALINHAMENTO LEOBERTO LEAL SC-408

Estaca: 2+060,00

Área de Corte: 0,38m<sup>2</sup>  
 Área de Aterro: 3,10m<sup>2</sup>  
 Volume Acumulado: 7.187,09m<sup>3</sup>  
 Cota Projeto: 502,685m

PLATAFORMA ACABADA LADO ESQUERDO	PTO	1	2	3	4	5	6	33
	DIST	3,300	3,409	3,618	3,698	3,907	4,016	4,825
	COTA	502,603m	502,603m	502,480m	502,480m	502,603m	502,603m	501,793m

PLATAFORMA ACABADA LADO DIREITO	PTO	1	2	3	4	5	33
	DIST	3,300m	3,409m	3,618m	3,698m	3,907m	4,016m
	COTA	502,603m	502,603m	502,480m	502,480m	502,603m	502,603m

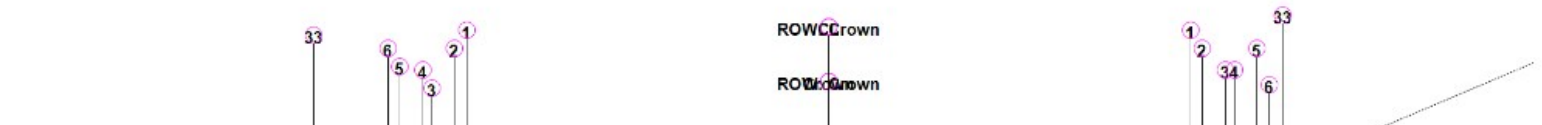

ALINHAMENTO LEOBERTO LEAL SC-408

Estaca: 2+080,00

Área de Corte: 0,00m<sup>2</sup>  
 Área de Aterro: 3,73m<sup>2</sup>  
 Volume Acumulado: 7.122,07m<sup>3</sup>  
 Cota Projeto: 502,309m

PLATAFORMA ACABADA LADO ESQUERDO	PTO	1	2	3	4	5	6	33
	DIST	3,300	3,409	3,618	3,698	3,907	4,016	4,697
	COTA	502,226m	502,226m	502,103m	502,103m	502,226m	502,226m	501,545m

PLATAFORMA ACABADA LADO DIREITO	PTO	1	2	3	4	5	6	33
	DIST	3,300m	3,409m	3,618m	3,698m	3,907m	4,016m	4,140m
	COTA	502,226m	502,226m	502,103m	502,103m	502,226m	502,226m	502,102m

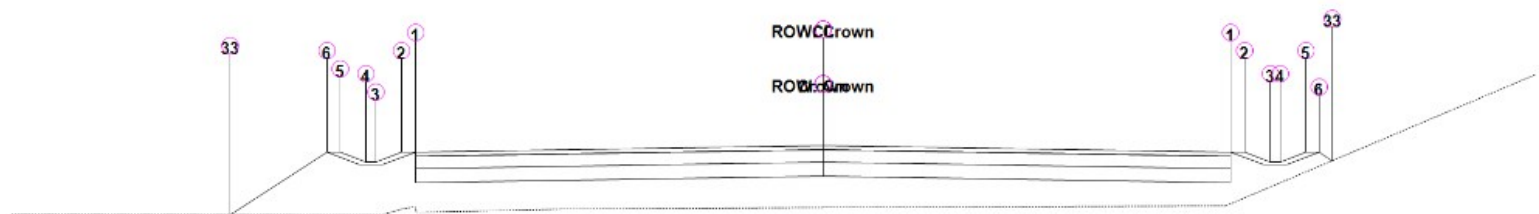

ALINHAMENTO LEOBERTO LEAL SC-408

Estaca: 2+086,23

Área de Corte: 0,00m<sup>2</sup>  
 Área de Aterro: 3,39m<sup>2</sup>  
 Volume Acumulado: 7.099,77m<sup>3</sup>  
 Cota Projeto: 502,198m

PLATAFORMA ACABADA LADO ESQUERDO	PTO	1	2	3	4	5	6	33
	DIST	3,300	3,409	3,618	3,698	3,907	4,016	4,797
	COTA	502,116m	502,116m	501,993m	501,993m	502,116m	502,116m	501,334m

PLATAFORMA ACABADA LADO DIREITO	PTO	1	2	3	4	5	6	33
	DIST	3,300m	3,409m	3,618m	3,698m	3,907m	4,016m	4,122m
	COTA	502,116m	502,116m	501,993m	501,993m	502,116m	502,116m	502,010m

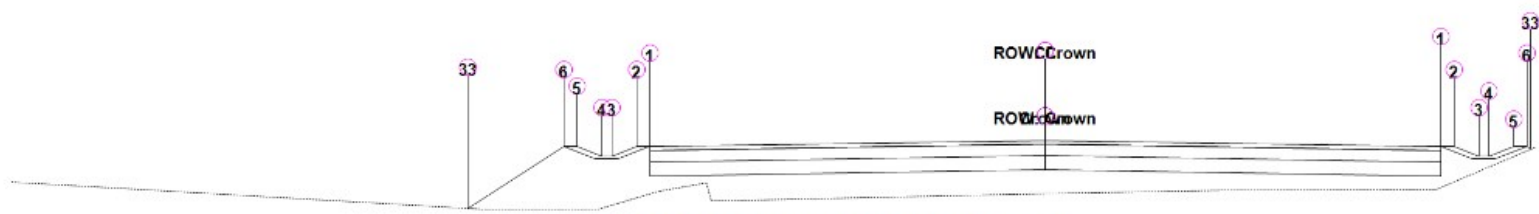

ALINHAMENTO LEOBERTO LEAL SC-408

Estaca: 2+100,00

Área de Corte: 0,00m<sup>2</sup>  
 Área de Aterro: 2,70m<sup>2</sup>  
 Volume Acumulado: 7.057,80m<sup>3</sup>  
 Cota Projeto: 501,965m

PLATAFORMA ACABADA LADO ESQUERDO	PTO	1	2	3	4	5	6	33
	DIST	3,300	3,409	3,618	3,698	3,907	4,016	4,819
	COTA	501,883m	501,883m	501,760m	501,760m	501,883m	501,883m	501,079m

PLATAFORMA ACABADA LADO DIREITO	PTO	1	2	3	4	5	6	33
	DIST	3,300m	3,409m	3,618m	3,698m	3,907m	4,016m	4,048m
	COTA	501,883m	501,883m	501,760m	501,760m	501,883m	501,883m	501,850m

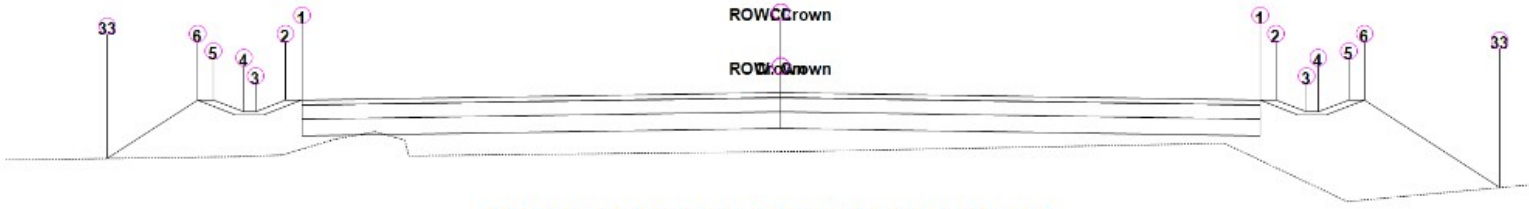

ALINHAMENTO LEOBERTO LEAL SC-408

Estaca: 2+112,68

Área de Corte: 0,00m<sup>2</sup>  
 Área de Aterro: 2,82m<sup>2</sup>  
 Volume Acumulado: 7.022,82m<sup>3</sup>  
 Cota Projeto: 501,764m

PLATAFORMA ACABADA LADO ESQUERDO	PTO	1	2	3	4	5	6	33
	DIST	3,300	3,409	3,618	3,698	3,907	4,016	4,639
	COTA	501,682m	501,682m	501,559m	501,559m	501,682m	501,682m	501,058m

PLATAFORMA ACABADA LADO DIREITO	PTO	1	2	3	4	5	6	33
	DIST	3,300m	3,409m	3,618m	3,698m	3,907m	4,016m	4,946m
	COTA	501,682m	501,682m	501,559m	501,559m	501,682m	501,682m	500,752m

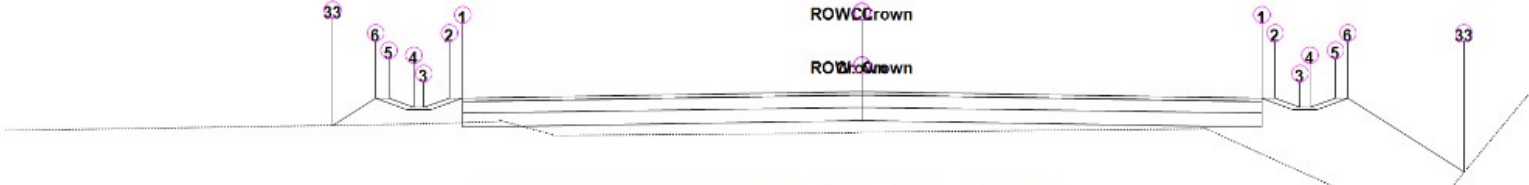

ALINHAMENTO LEOBERTO LEAL SC-408

Estaca: 2+120,00

Área de Corte: 0,03m<sup>2</sup>  
 Área de Aterro: 2,43m<sup>2</sup>  
 Volume Acumulado: 7.003,72m<sup>3</sup>  
 Cota Projeto: 501,654m

PLATAFORMA ACABADA	PTO	1	2	3	4	5	6	33
	DIST	3,300	3,409	3,618	3,698	3,907	4,016	4,079
	COTA	501,654m	501,654m	501,531m	501,531m	501,654m	501,654m	500,929m

LADO ESQUERDO	DIST	3,300	3,409	3,618	3,698	3,907	4,016	4,373
	COTA	501,572m	501,572m	501,449m	501,449m	501,572m	501,572m	501,214m

PLATAFORMA ACABADA LADO DIREITO	PTO	1	2	3	4	5	6	33
	DIST	3,300m	3,409m	3,618m	3,698m	3,907m	4,016m	4,970m
	COTA	501,572m	501,572m	501,449m	501,449m	501,572m	501,572m	500,617m

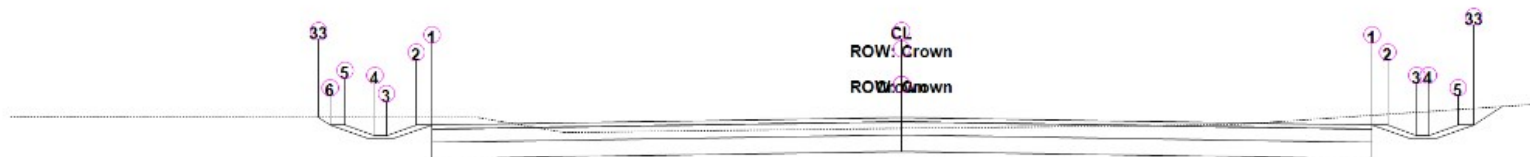

ALINHAMENTO LEOBERTO LEAL SC-408

Estaca: 2+139,13

Área de Corte: 2,43m<sup>2</sup>  
 Área de Aterro: 0,00m<sup>2</sup>  
 Volume Acumulado: 7.003,97m<sup>3</sup>  
 Cota Projeto: 501,388m

PLATAFORMA ACABADA LADO ESQUERDO	PTO	1	2	3	4	5	6	33
	DIST	3,300	3,409	3,618	3,698	3,907	4,016	4,097
	COTA	501,305m	501,305m	501,182m	501,182m	501,305m	501,305m	501,387m

PLATAFORMA ACABADA LADO DIREITO	PTO	1	2	3	4	5	33
	DIST	3,300m	3,409m	3,618m	3,698m	3,907m	4,016m
	COTA	501,305m	501,305m	501,182m	501,182m	501,305m	501,305m



ALINHAMENTO LEOBERTO LEAL SC-408

Estaca: 2+140,00

Área de Corte: 2,58m<sup>2</sup>  
 Área de Aterro: 0,00m<sup>2</sup>  
 Volume Acumulado: 7.006,18m<sup>3</sup>  
 Cota Projeto: 501,376m

PLATAFORMA ACABADA LADO ESQUERDO	PTO	1	2	3	4	5	6	33
	DIST	3,300	3,409	3,618	3,698	3,907	4,016	4,107
	COTA	501,294m	501,294m	501,171m	501,171m	501,294m	501,294m	501,385m

PLATAFORMA ACABADA LADO DIREITO	PTO	1	2	3	4	5	33
	DIST	3,300m	3,409m	3,618m	3,698m	3,907m	4,016m
	COTA	501,294m	501,294m	501,171m	501,171m	501,294m	501,294m

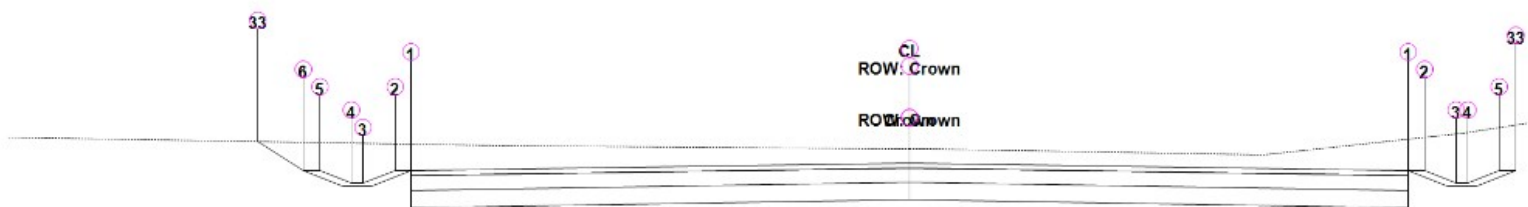

ALINHAMENTO LEOBERTO LEAL SC-408

Estaca: 2+160,00

Área de Corte: 4,44m<sup>2</sup>  
 Área de Aterro: 0,00m<sup>2</sup>  
 Volume Acumulado: 7.076,33m<sup>3</sup>  
 Cota Projeto: 501,131m

PLATAFORMA ACABADA LADO ESQUERDO	PTO	1	2	3	4	5	6	33
	DIST	3,300	3,409	3,618	3,698	3,907	4,016	4,318
	COTA	501,049m	501,049m	500,926m	500,926m	501,049m	501,049m	501,351m

PLATAFORMA ACABADA LADO DIREITO	PTO	1	2	3	4	5	33
	DIST	3,300m	3,409m	3,618m	3,698m	3,907m	4,016m
	COTA	501,049m	501,049m	500,926m	500,926m	501,049m	501,049m

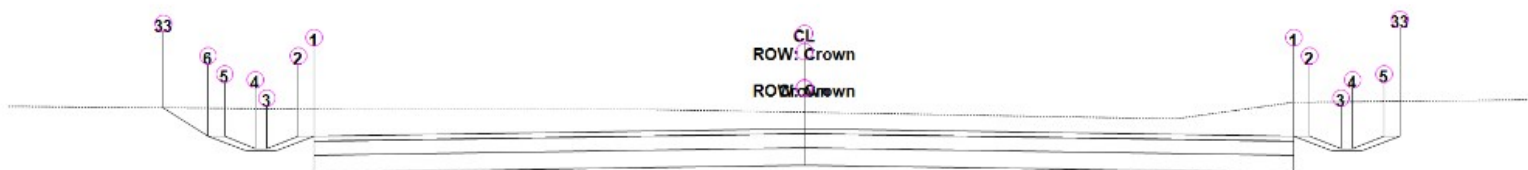

ALINHAMENTO LEOBERTO LEAL SC-408

Estaca: 2+180,00

Área de Corte: 4,54m<sup>2</sup>  
 Área de Aterro: 0,00m<sup>2</sup>  
 Volume Acumulado: 7.166,07m<sup>3</sup>  
 Cota Projeto: 500,919m

PLATAFORMA ACABADA LADO ESQUERDO	PTO	1	2	3	4	5	6	33
	DIST	3,300	3,409	3,618	3,698	3,907	4,016	4,316
	COTA	500,836m	500,836m	500,713m	500,713m	500,836m	500,836m	501,137m

PLATAFORMA ACABADA LADO DIREITO	PTO	1	2	3	4	5	33
	DIST	3,300m	3,409m	3,618m	3,698m	3,907m	4,016m
	COTA	500,836m	500,836m	500,713m	500,713m	500,836m	500,836m

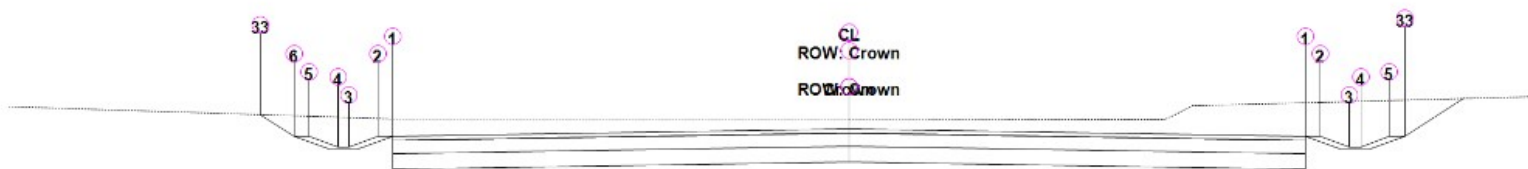

ALINHAMENTO LEOBERTO LEAL SC-408

Estaca: 2+200,00

Área de Corte: 4,33m<sup>2</sup>  
 Área de Aterro: 0,00m<sup>2</sup>  
 Volume Acumulado: 7.254,79m<sup>3</sup>  
 Cota Projeto: 500,739m

PLATAFORMA ACABADA LADO ESQUERDO	PTO	1	2	3	4	5	6	33
	DIST	3,300	3,409	3,618	3,698	3,907	4,016	4,258
	COTA	500,657m	500,657m	500,534m	500,534m	500,657m	500,657m	500,899m

PLATAFORMA ACABADA LADO DIREITO	PTO	1	2	3	4	5	33
	DIST	3,300m	3,409m	3,618m	3,698m	3,907m	4,016m
	COTA	500,657m	500,657m	500,534m	500,534m	500,657m	500,657m

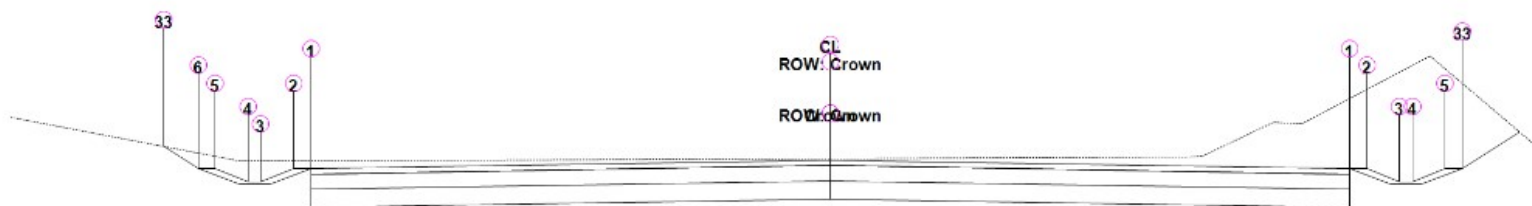

ALINHAMENTO LEOBERTO LEAL SC-408

Estaca: 2+220,00

Área de Corte: 4,21m<sup>2</sup>  
 Área de Aterro: 0,00m<sup>2</sup>  
 Volume Acumulado: 7.340,21m<sup>3</sup>  
 Cota Projeto: 500,592m

PLATAFORMA ACABADA LADO ESQUERDO	PTO	1	2	3	4	5	6	33
	DIST	3,300	3,409	3,618	3,698	3,907	4,016	4,238
	COTA	500,510m	500,510m	500,387m	500,387m	500,510m	500,510m	500,732m

PLATAFORMA ACABADA LADO DIREITO	PTO	1	2	3	4	5	33
	DIST	3,300m	3,409m	3,618m	3,698m	3,907m	4,016m
	COTA	500,510m	500,510m	500,387m	500,387m	500,510m	500,510m

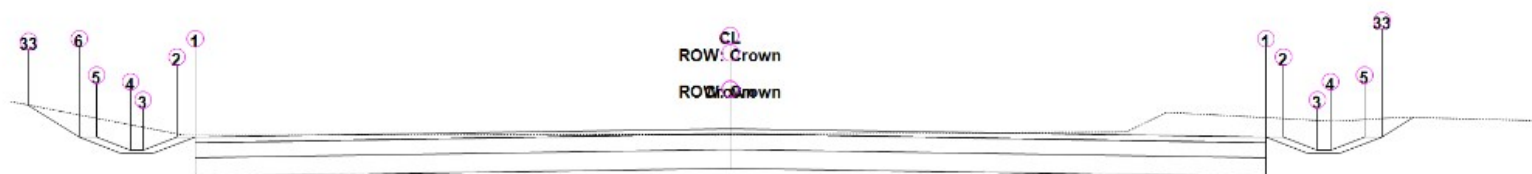

ALINHAMENTO LEOBERTO LEAL SC-408

Estaca: 2+240,00

Área de Corte: 2,97m<sup>2</sup>  
 Área de Aterro: 0,00m<sup>2</sup>  
 Volume Acumulado: 7.412,00m<sup>3</sup>  
 Cota Projeto: 500,458m



PLATAFORMA ACABADA LADO ESQUERDO	PTO	1	2	3	4	5	6	33
	DIST	3,300	3,409	3,618	3,698	3,907	4,016	4,325
	COTA	500,375m	500,375m	500,252m	500,252m	500,375m	500,375m	500,684m

PLATAFORMA ACABADA LADO DIREITO	PTO	1	2	3	4	5	33
	DIST	3,300m	3,409m	3,618m	3,698m	3,907m	4,016m
	COTA	500,375m	500,375m	500,252m	500,252m	500,375m	500,375m

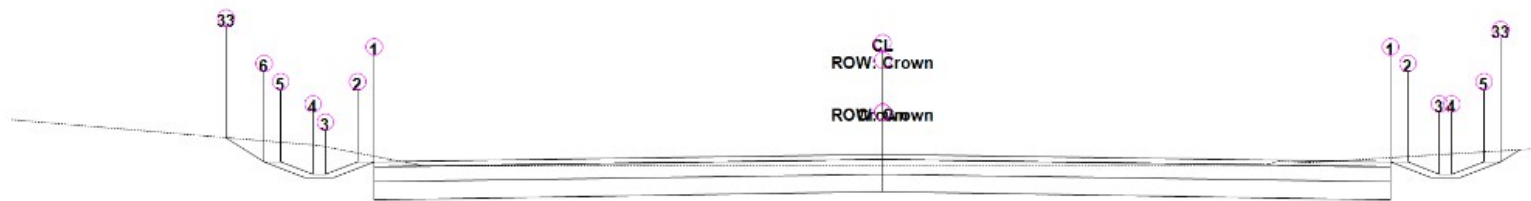

ALINHAMENTO LEOBERTO LEAL SC-408

Estaca: 2+260,00

Área de Corte: 2,42m<sup>2</sup>  
 Área de Aterro: 0,00m<sup>2</sup>  
 Volume Acumulado: 7.465,94m<sup>3</sup>  
 Cota Projeto: 500,325m

PLATAFORMA ACABADA LADO ESQUERDO	PTO	1	2	3	4	5	6	33
	DIST	3,300	3,409	3,618	3,698	3,907	4,016	4,265
	COTA	500,242m	500,242m	500,119m	500,119m	500,242m	500,242m	500,491m

PLATAFORMA ACABADA LADO DIREITO	PTO	1	2	3	4	5	33
	DIST	3,300m	3,409m	3,618m	3,698m	3,907m	4,016m
	COTA	500,242m	500,242m	500,119m	500,119m	500,242m	500,242m

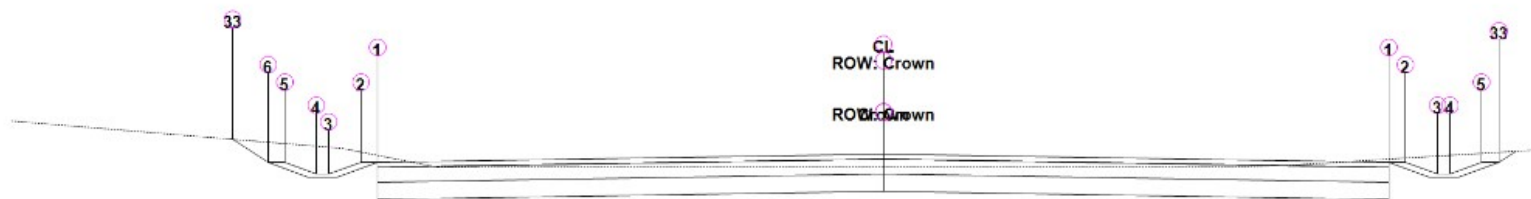

ALINHAMENTO LEOBERTO LEAL SC-408

Estaca: 2+263,45

Área de Corte: 2,31m<sup>2</sup>  
 Área de Aterro: 0,00m<sup>2</sup>  
 Volume Acumulado: 7.474,11m<sup>3</sup>  
 Cota Projeto: 500,306m

PLATAFORMA ACABADA LADO ESQUERDO	PTO	1	2	3	4	5	6	33
	DIST	3,300	3,409	3,618	3,698	3,907	4,016	4,246
	COTA	500,223m	500,223m	500,100m	500,100m	500,223m	500,223m	500,454m

PLATAFORMA	PTO	1	2	3	4	5	33
------------	-----	---	---	---	---	---	----

ACABADA	DIST	3,300m	3,409m	3,618m	3,698m	3,907m	4,016m
LADO DIREITO	COTA	500,223m	500,223m	500,100m	500,100m	500,223m	500,223m

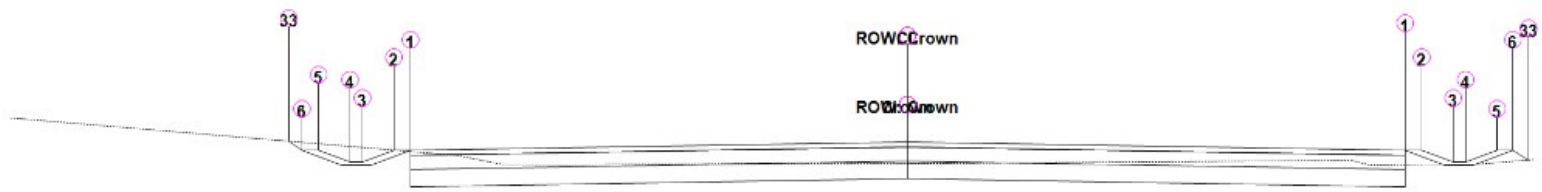

ALINHAMENTO LEOBERTO LEAL SC-408

Estaca: 2+280,00

Área de Corte: 1,49m<sup>2</sup>  
 Área de Aterro: 0,04m<sup>2</sup>  
 Volume Acumulado: 7.505,29m<sup>3</sup>  
 Cota Projeto: 500,245m

PLATAFORMA ACABADA LADO ESQUERDO	PTO	1	2	3	4	5	6	33
	DIST	3,300	3,409	3,618	3,698	3,907	4,016	4,105
	COTA	500,163m	500,163m	500,040m	500,040m	500,163m	500,163m	500,252m

PLATAFORMA ACABADA LADO DIREITO	PTO	1	2	3	4	5	6	33
	DIST	3,300m	3,409m	3,618m	3,698m	3,907m	4,016m	4,120m
	COTA	500,163m	500,163m	500,040m	500,040m	500,163m	500,163m	500,058m

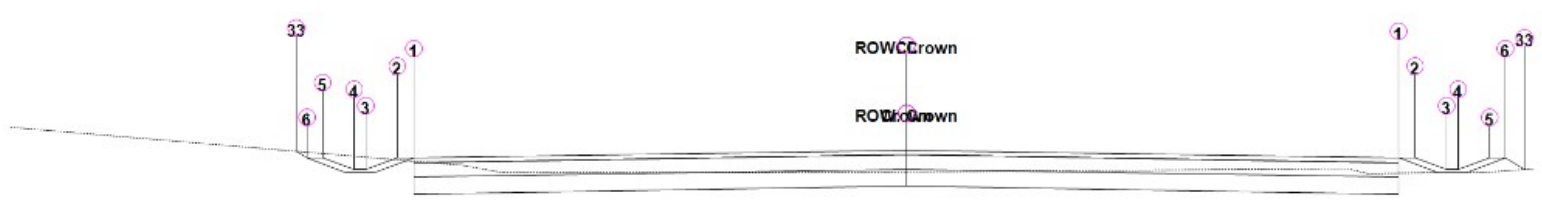

ALINHAMENTO LEOBERTO LEAL SC-408

Estaca: 2+281,38

Área de Corte: 1,41m<sup>2</sup>  
 Área de Aterro: 0,05m<sup>2</sup>  
 Volume Acumulado: 7.507,24m<sup>3</sup>  
 Cota Projeto: 500,242m

PLATAFORMA ACABADA LADO ESQUERDO	PTO	1	2	3	4	5	6	33
	DIST	3,300	3,409	3,618	3,698	3,907	4,016	4,087
	COTA	500,160m	500,160m	500,037m	500,037m	500,160m	500,160m	500,231m

PLATAFORMA ACABADA LADO DIREITO	PTO	1	2	3	4	5	6	33
	DIST	3,300m	3,409m	3,618m	3,698m	3,907m	4,016m	4,139m
	COTA	500,160m	500,160m	500,037m	500,037m	500,160m	500,160m	500,037m



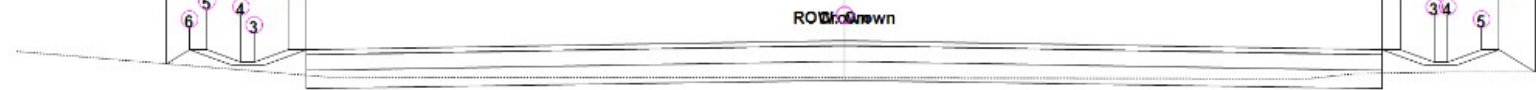

ALINHAMENTO LEOBERTO LEAL SC-408

Estaca: 2+299,32

Área de Corte: 0,42m<sup>2</sup>  
 Área de Aterro: 0,20m<sup>2</sup>  
 Volume Acumulado: 7.521,45m<sup>3</sup>  
 Cota Projeto: 500,241m

PLATAFORMA ACABADA LADO ESQUERDO	PTO	1	2	3	4	5	6	33
	DIST	3,300	3,409	3,618	3,698	3,907	4,016	4,156
	COTA	500,158m	500,158m	500,035m	500,035m	500,158m	500,158m	500,017m

PLATAFORMA ACABADA LADO DIREITO	PTO	1	2	3	4	5	6	33
	DIST	3,300m	3,409m	3,618m	3,698m	3,907m	4,016m	4,235m
	COTA	500,158m	500,158m	500,035m	500,035m	500,158m	500,158m	499,938m

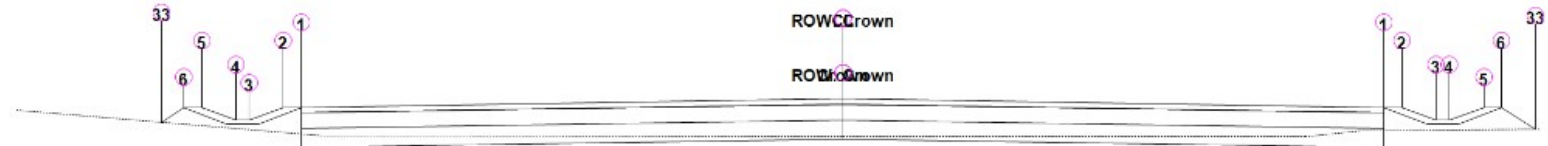

ALINHAMENTO LEOBERTO LEAL SC-408

Estaca: 2+300,00

Área de Corte: 0,44m<sup>2</sup>  
 Área de Aterro: 0,19m<sup>2</sup>  
 Volume Acumulado: 7.521,61m<sup>3</sup>  
 Cota Projeto: 500,242m

PLATAFORMA ACABADA LADO ESQUERDO	PTO	1	2	3	4	5	6	33
	DIST	3,300	3,409	3,618	3,698	3,907	4,016	4,155
	COTA	500,159m	500,159m	500,036m	500,036m	500,159m	500,159m	500,020m

PLATAFORMA ACABADA LADO DIREITO	PTO	1	2	3	4	5	6	33
	DIST	3,300m	3,409m	3,618m	3,698m	3,907m	4,016m	4,224m
	COTA	500,159m	500,159m	500,036m	500,036m	500,159m	500,159m	499,951m

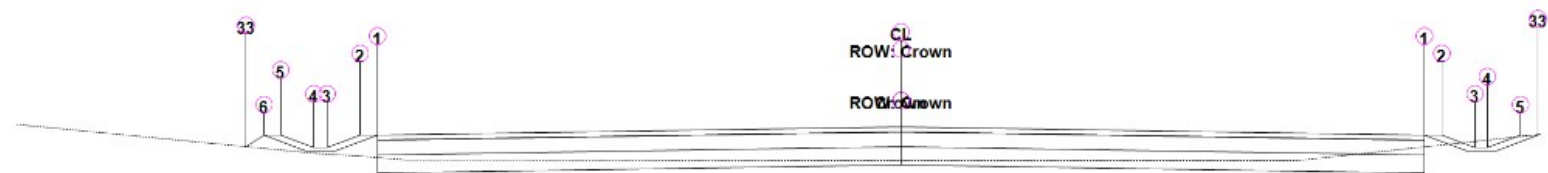

ALINHAMENTO LEOBERTO LEAL SC-408

Estaca: 2+320,00

Área de Corte: 0,65m<sup>2</sup>  
 Área de Aterro: 0,08m<sup>2</sup>  
 Volume Acumulado: 7.529,82m<sup>3</sup>

Cota Projeto: 500,315m

PLATAFORMA ACABADA LADO ESQUERDO	PTO	1	2	3	4	5	6	33
	DIST	3,300	3,409	3,618	3,698	3,907	4,016	4,130
	COTA	500,233m	500,233m	500,110m	500,110m	500,233m	500,233m	500,119m

PLATAFORMA ACABADA LADO DIREITO	PTO	1	2	3	4	5	33
	DIST	3,300m	3,409m	3,618m	3,698m	3,907m	4,016m
	COTA	500,233m	500,233m	500,110m	500,110m	500,233m	500,233m

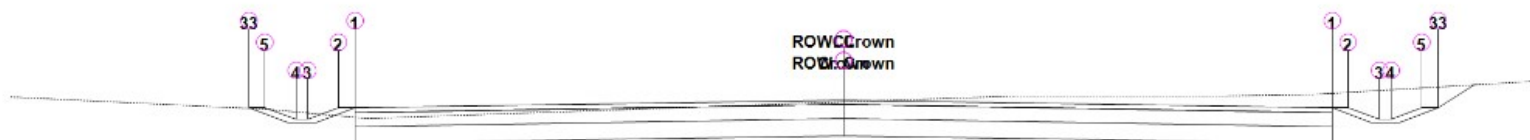

ALINHAMENTO LEOBERTO LEAL SC-408

Estaca: 2+340,00

Área de Corte: 2,79m<sup>2</sup>  
 Área de Aterro: 0,01m<sup>2</sup>  
 Volume Acumulado: 7.563,38m<sup>3</sup>  
 Cota Projeto: 500,465m

PLATAFORMA ACABADA LADO ESQUERDO	PTO	1	2	3	4	5	33
	DIST	3,300	3,409	3,618	3,698	3,907	4,016
	COTA	500,382m	500,382m	500,259m	500,259m	500,382m	500,382m

PLATAFORMA ACABADA LADO DIREITO	PTO	1	2	3	4	5	33
	DIST	3,300m	3,409m	3,618m	3,698m	3,907m	4,016m
	COTA	500,382m	500,382m	500,259m	500,259m	500,382m	500,382m

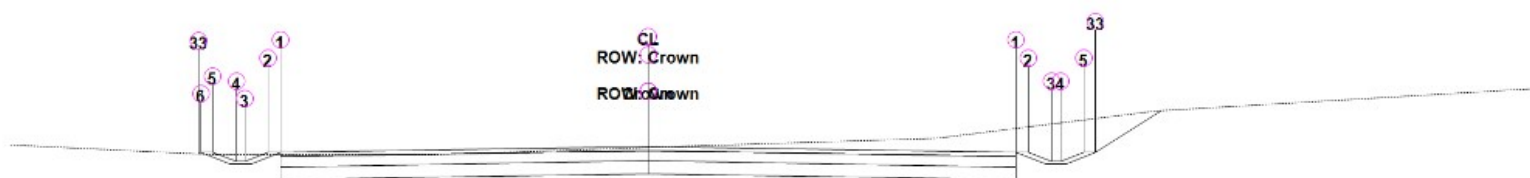

ALINHAMENTO LEOBERTO LEAL SC-408

Estaca: 2+352,03

Área de Corte: 3,32m<sup>2</sup>  
 Área de Aterro: 0,00m<sup>2</sup>  
 Volume Acumulado: 7.600,08m<sup>3</sup>  
 Cota Projeto: 500,592m

PLATAFORMA ACABADA LADO ESQUERDO	PTO	1	2	3	4	5	6	33
	DIST	3,300	3,409	3,618	3,698	3,907	4,016	4,033
	COTA	500,509m	500,509m	500,386m	500,386m	500,509m	500,509m	500,492m

PLATAFORMA ACABADA LADO DIREITO	PTO	1	2	3	4	5	33
	DIST	3,300m	3,409m	3,618m	3,698m	3,907m	4,016m
	COTA	500,509m	500,509m	500,386m	500,386m	500,509m	500,509m

LADO DIREITO	COTA	500,509m	500,509m	500,386m	500,386m	500,509m	500,509m
--------------	------	----------	----------	----------	----------	----------	----------



ALINHAMENTO LEOBERTO LEAL SC-408

Estaca: 2+360,00

Área de Corte: 3,14m<sup>2</sup>  
 Área de Aterro: 0,00m<sup>2</sup>  
 Volume Acumulado: 7.625,83m<sup>3</sup>  
 Cota Projeto: 500,691m

PLATAFORMA ACABADA LADO ESQUERDO	PTO	1	2	3	4	5	6	33
	DIST	3,300	3,409	3,618	3,698	3,907	4,016	4,030
	COTA	500,609m	500,609m	500,486m	500,486m	500,609m	500,609m	500,623m

PLATAFORMA ACABADA LADO DIREITO	PTO	1	2	3	4	5	33
	DIST	3,300m	3,409m	3,618m	3,698m	3,907m	4,016m
	COTA	500,609m	500,609m	500,486m	500,486m	500,609m	500,609m



ALINHAMENTO LEOBERTO LEAL SC-408

Estaca: 2+380,00

Área de Corte: 2,79m<sup>2</sup>  
 Área de Aterro: 0,00m<sup>2</sup>  
 Volume Acumulado: 7.685,15m<sup>3</sup>  
 Cota Projeto: 500,991m

PLATAFORMA ACABADA LADO ESQUERDO	PTO	1	2	3	4	5	6	33
	DIST	3,300	3,409	3,618	3,698	3,907	4,016	4,041
	COTA	500,909m	500,909m	500,786m	500,786m	500,909m	500,909m	500,934m

PLATAFORMA ACABADA LADO DIREITO	PTO	1	2	3	4	5	33
	DIST	3,300m	3,409m	3,618m	3,698m	3,907m	4,016m
	COTA	500,909m	500,909m	500,786m	500,786m	500,909m	500,909m



ALINHAMENTO LEOBERTO LEAL SC-408

Estaca: 2+400,00

Área de Corte: 2,27m<sup>2</sup>  
 Área de Aterro: 0,11m<sup>2</sup>  
 Volume Acumulado: 7.734,67m<sup>3</sup>  
 Cota Projeto: 501,310m

PLATAFORMA ACABADA LADO ESQUERDO	PTO	1	2	3	4	5	6	33
	DIST	3,300	3,409	3,618	3,698	3,907	4,016	4,156
	COTA	501,228m	501,228m	501,105m	501,105m	501,228m	501,228m	501,087m

PLATAFORMA ACABADA LADO DIREITO	PTO	1	2	3	4	5	33
	DIST	3,300m	3,409m	3,618m	3,698m	3,907m	4,016m
	COTA	501,228m	501,228m	501,105m	501,105m	501,228m	501,228m

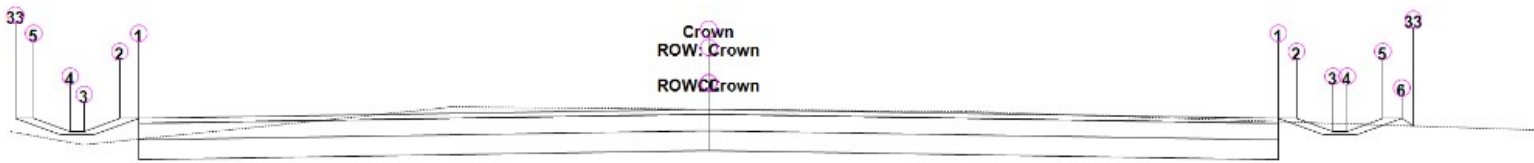

ALINHAMENTO LEOBERTO LEAL SC-408

Estaca: 2+404,74

Área de Corte: 2,47m<sup>2</sup>  
 Área de Aterro: 0,08m<sup>2</sup>  
 Volume Acumulado: 7.745,46m<sup>3</sup>  
 Cota Projeto: 501,386m

PLATAFORMA ACABADA LADO ESQUERDO	PTO	1	2	3	4	5	33
	DIST	3,300	3,409	3,618	3,698	3,907	4,016
	COTA	501,303m	501,303m	501,180m	501,180m	501,303m	501,303m

PLATAFORMA ACABADA LADO DIREITO	PTO	1	2	3	4	5	6	33
	DIST	3,300m	3,409m	3,618m	3,698m	3,907m	4,016m	4,085m
	COTA	501,303m	501,303m	501,180m	501,180m	501,303m	501,303m	501,234m